



Varuwan Vadivelan Institute of Technology

Dharmapuri – 636 703.

LAB MANUAL

Regulation : 2013

Branch : *B.E.* – ECE

Year & Semester : III Year / V Semester

EC6512- COMMUNICATION SYSTEMS LABORATORY

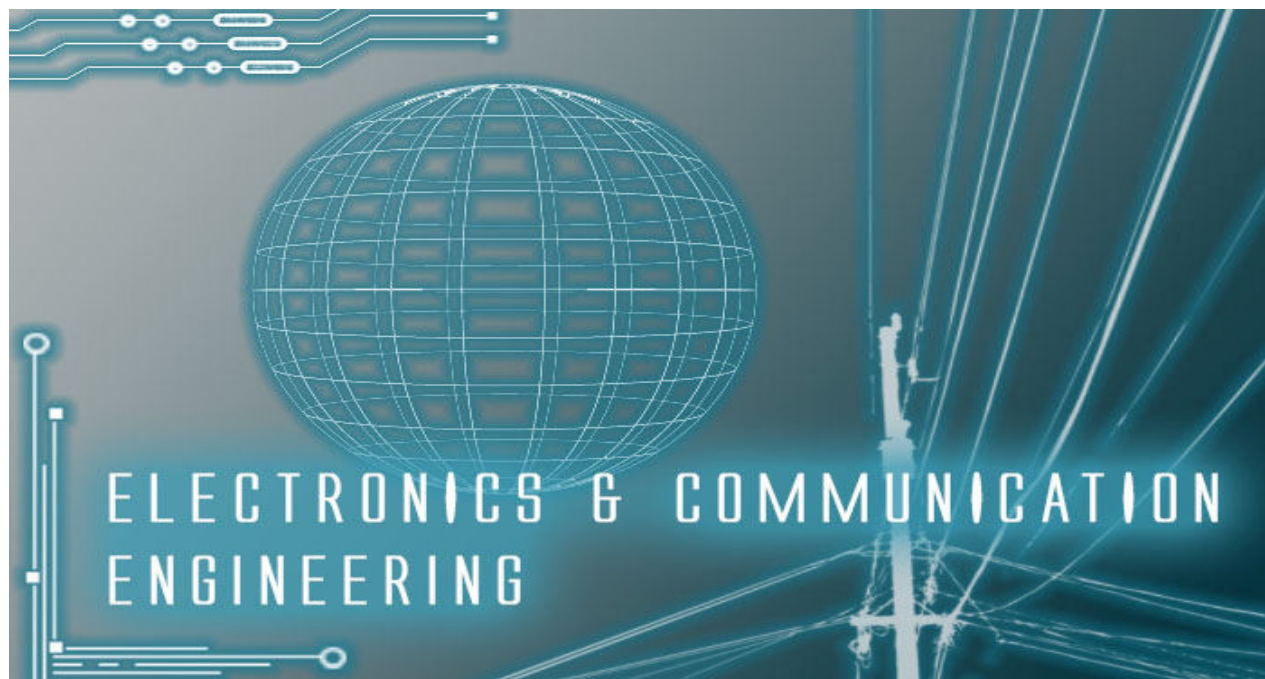

INTRODUCTION

Exchanging information between two systems or human beings is called as communication. The information's in terms of binary digits called as digital data and electrical signals called as analog data.

The Communication System Lab is designed to help students understand the basic principles of communication techniques as well as giving them the insight on design, simulation and hardware implementation of circuits.

The main aim is to provide hands-on experience to the students so that they are able to put theoretical concepts to practice. The content of this course consists of two parts, 'simulation' and 'hardwired'. Computer simulation is stressed upon as it is a key analysis tool of engineering design.

MATLAB software is used for simulation of communication experiments. Students will carry out design experiments as a part of the experiments list provided in this lab manual.

Students will be given a specific design problem, which after completion they will verify using the simulation software or hardwired implementation.

ANNA UNIVERSITY: CHENNAI

REGULATION 2013

EC6512 – COMMUNICATION SYSTEMS LABORATORY

LIST OF EXPERIMENTS:

1. Signal Sampling and reconstruction
2. Time Division Multiplexing
3. AM Modulator and Demodulator
4. FM Modulator and Demodulator
5. Pulse Code Modulation and Demodulation
6. Delta Modulation and Demodulation
7. Observation (simulation) of signal constellations of BPSK, QPSK and QAM
8. Line coding schemes
9. FSK, PSK and DPSK schemes (Simulation)
10. Error control coding schemes – Linear Block Codes (Simulation)
11. Communication link simulation
12. Equalization – Zero Forcing & LMS algorithms (simulation)

TOTAL: 45 PERIODS

LIST OF EXPERIMENTS

S.no	Date	Name of the Experiment	Page no	Marks	Signature
1		Signal Sampling and reconstruction			
2		Time Division Multiplexing			
3		AM Modulator and Demodulator			
4		FM Modulator and Demodulator			
5		Pulse Code Modulation and Demodulation			
6		Delta Modulation and Demodulation			
7		Observation (simulation) of signal constellations of BPSK, QPSK and QAM			
8		Line coding schemes			
9		FSK, PSK and DPSK schemes (Simulation)			
10		Error control coding schemes – Linear Block Codes (Simulation)			
11		Communication link simulation			
12		Equalization – Zero Forcing & LMS algorithms (simulation)			

EC6512 – Communication Systems Laboratory

Exp.No.: 1

Date:

SAMPLING AND RECONSTRUCTION OF ANALOG SIGNALS

AIM:

To study the signal sampling and reconstruction of analog signals.

APPARATUS REQUIRED:

1. Sampling and Reconstruction Kit
2. Patch Cords
3. Probes
4. DSO

THEORY:

A band limited signal of finite energy has no frequency components higher than 'W' hertz is completely described by specified the values of the signal of instants of time separated by $1/2W$ seconds, where 'W' is the higher frequency content. The zero order hold circuit is used for practical reconstruction. It simply holds the value $x(n)$ for 'T' seconds. Here 'T' is the sampling period; The output of zero order hold is stair case signal. The reconstructed signal is the succession of sine pulses weighted by $x(nT_s)$ these pulses are interpolated with the help of a LPF. It is also called reconstruction filter or interpolation filter Natural sampling is chopper sampling because the waveform of the sampled signal appears to be chopped off from the original signal waveform. The top of the samples remains constant and equal to instantaneous value of $x(t)$ at start of sampling $f_s = 1/T_s$

PROCEDURE:

1. Connect the main plug in to the main board. Keep the power switch in OFF position.
2. Put the duty cycle selector switch in position 50%
3. Link 25 Hz sine wave output to analog input.
4. Turn on the trainer.
5. Turning on the trainer select 250 Hz sampling rate by default.
6. Display 25Hz sine wave and sampled output on t oscilloscope. This display shows 25Hz sine wave being sampled at 200 Hz there are 10 samples for every cycle of the sine wave.

EC6512 – Communication Systems Laboratory

7. Link the sample output to the fourth order low pass filter display sample output and output of the filter in the oscilloscope. The display shows the reconstructed original 21 Hz sine wave.
8. We had used sampling frequency greater than twice the maximum input frequency.
9. Remove the line from 25KHz sine wave output to the modulating input.
10. By successive process of frequency selector switch change the sampling frequency 32 KHz, 16KHz, 8 KHz,4 KHz,2 KHz,1 KHz,50 Hz and back to 250 Hz
11. Observe how sample output changes in each cases and how the lower sampling frequencies introduce distortion in to the filter output waveform. This is due to the fact that the filter does not attenuate the unwanted next frequency component significantly use of higher order filter would improve the output waveform.
12. So far we have used sampling frequencies greater than twice the maximum input frequency. To set the nyquist criteria set sampling rate 4 Hz 50% duty cycle.
13. Remove the link 25 Hz sine wave output to the modulating input.
14. Connect the link from 250 Hz or 500 Hz sine wave output to the modulating input and link the sampled output to fourth order LPF. Display sample output and output of the filter on the oscilloscope. The display shows the reconstruction signal 250 Hz or 500Hz sine wave.
15. Now decrease the sampling rate to 32 KHz and then to 500 Hz. Observe the distorted fact that we under sampled the input waveform overlooking the nyquist criteria and thus the output was distorted even though the signal below the cutoff frequency of the filter. This is also describes the phenomenon of aliasing.

FUNCTIONAL BLOCK DIAGRAM:

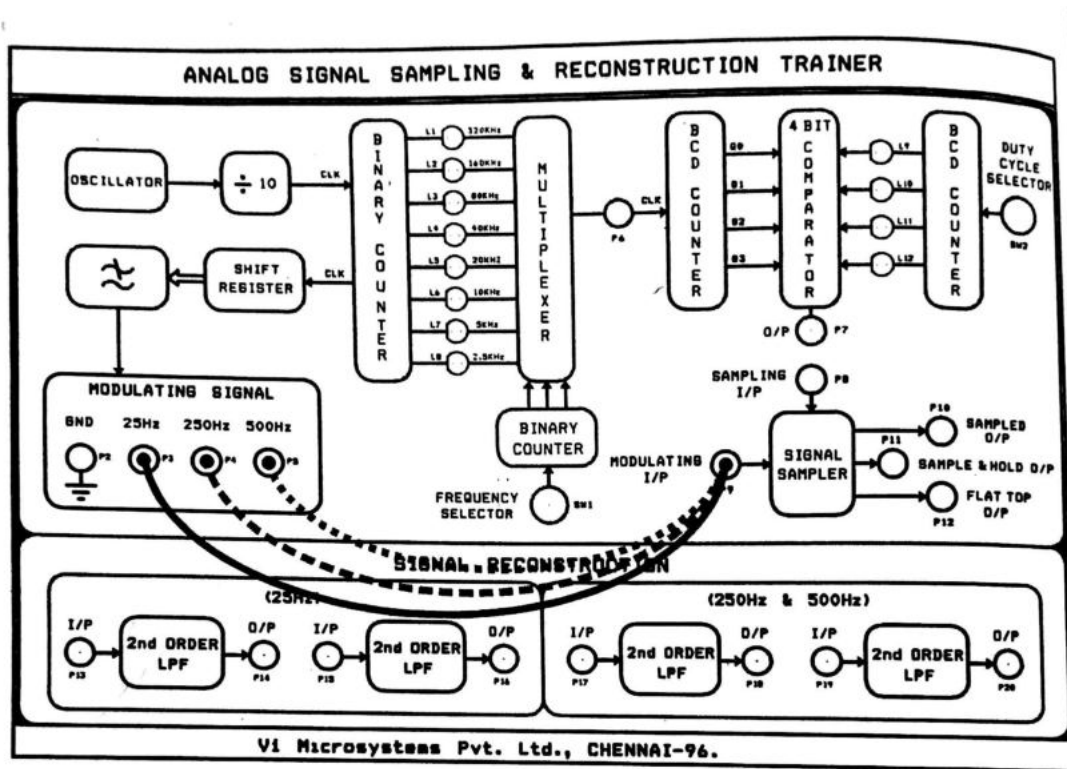

Outputs :

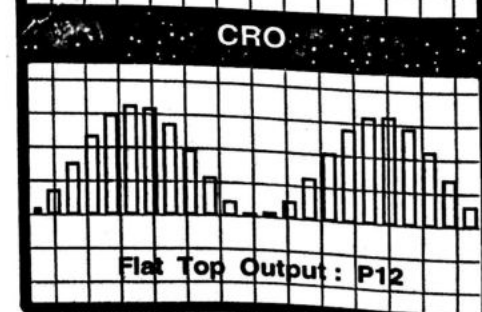
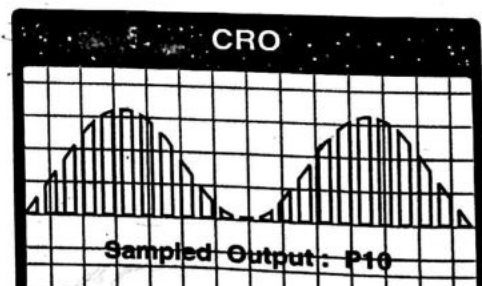
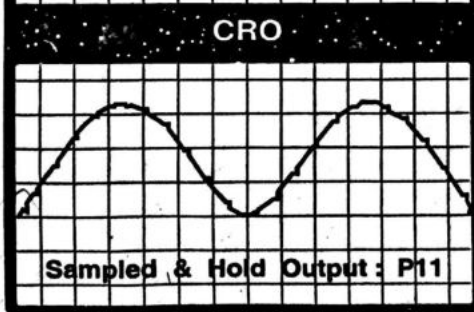
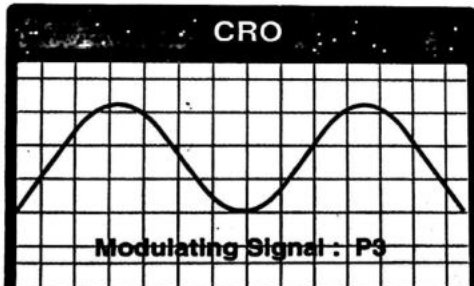

EC6512 – Communication Systems Laboratory

TABULATION:

Parameters	Amplitude (V)	Time period (ms)	Frequency (Hz)
Modulation signal			
Sampled output			
Sampled & hold output			
Flat top output			
Demodulated signal			

RESULT:

Thus the signal sampling and reconstruction techniques were performed and graph plotted.

EC6512 – Communication Systems Laboratory

Exp.No.: 2

Date:

TIME DIVISION MULTIPLEXING (TDM)

AIM:

To write a Matlab program for time division multiplexing (TDM) and plot the characteristics curve.

APPARATUS REQUIRED:

1. Computer
2. Matlab software R2014a

THEORY:

Time division multiplexing (TDM) is the process of sending more than one source information over a same channel in different time slot which helps in efficient channel utilization and saves bandwidth.

PROCEDURE:

1. Open Matlab version R2014a.
2. Open new file and enter the program and save it.
3. Add the path to the location of the file in the system.
4. Compile the program and check for any error and debug it.
5. Note down the output.

MATLAB CODING:

```
n1=input ('Enter the length= ');
n2=input ('Enter the length= ');
n3=input ('Enter the length= ');
t=0:0.01:n1;
t1=1:0.01:n2;
t2=2:0.01:n3;
x=sin (2*pi*t);
y=sin (4*pi*t1);
z=sin (6*pi*t2);
subplot (4,1,1);
plot (t,x,'g');
title ('USER 1');
grid on;
Subplot (4, 1, 2);
```

EC6512 – Communication Systems Laboratory

```
Plot (t1, y, 'r');  
title ('USER 2');  
gridon;  
subplot(4,1,3);  
plot(t2,z);  
title('USER 3');  
gridon;  
subplot(4,1,4);  
plot(t,x,'g',t1,y,'r',t2,z);  
TITLE('TIME DIVISION MULTIPLEXING');  
grid on;
```

INPUT:

Enter the length 1
Enter the length 2
Enter the length 3

OUTPUT WAVEFORM:

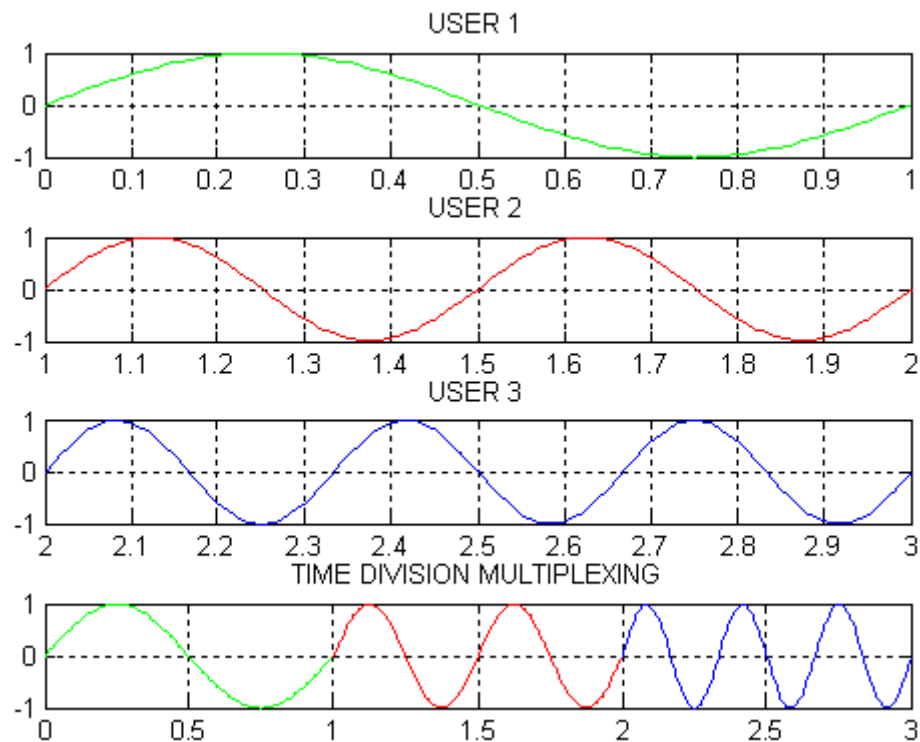

RESULT:

Thus the TDM signal was sampled and reconstructed using MATALB program and verified.

EC6512 – Communication Systems Laboratory

Exp. No.: 3

Date:

AMPLITUDE MODULATION AND DEMODULATION

AIM:

To perform the amplitude modulation and demodulation using AM Kit.

APPARATUS REQUIRED:

1. Amplitude modulation kit
2. DSO
3. Probes
4. Patch cords

MODULATION THEORY:

Modulation is defined as the process by which some characteristics of a carrier signal is varied in accordance with a modulating signal. The base band signal is referred to as the modulating signal and the output of the modulation process is called as the modulation signal.

The carrier frequency f_c must be much greater than the highest frequency components f_m of the message signal $m(t)$ i.e. $f_c \gg f_m$

The modulation index must be less than unity. if the modulation index is greater than unity, the carrier wave becomes over modulated.

DEMODULATION THEORY:

The process of detection provides a means of recovering the modulating Signal from modulating signal. Demodulation is the reverse process of modulation. The detector circuit is employed to separate the carrier wave and eliminate the side bands. Since the envelope of an AM wave has the same shape as the message, independent of the carrier frequency and phase, demodulation can be accomplished by extracting envelope.

The depth of modulation at the detector output greater than unity and circuit impedance is less than circuit load ($R_l > Z_m$) results in clipping of negative peaks of modulating signal. It is called “negative clipping “.

EC6512 – Communication Systems Laboratory

PROCEDURE:

A. Amplitude Modulation

1. Connect the mains cord of the trainer unit to AC 220V, 50 Hz supply.
2. Switch ON the trainer kit. The neon lamp will glow indicating that the unit is ready for operation.
3. Observe the waveforms of modulating signal and carrier signal in an Oscilloscope.
4. Using patch cords, connect the modulating signal and the carrier signal to 'AM MODULATION'.
5. Observe the amplitude modulated output waveform across sockets marked 'AM OUTPUT'.

B. AM Demodulation

1. Set the amplitude of modulating and carrier signal in Amplitude Modulation.
2. Using patch cords, connect the 'AM OUTPUT' from the AM Modulation to the sockets marked 'AM INPUT' in the AM Demodulation.
3. Connect the detector output to filter input using patch cords.
4. Connect the filter output to amplifier input.
5. Connect the amplifier output to inverting amplifier input.
6. Observe the demodulated output waveform across sockets marked 'DEMOD OUTPUT'.

FUNCTIONAL BLOCK DIAGRAM:

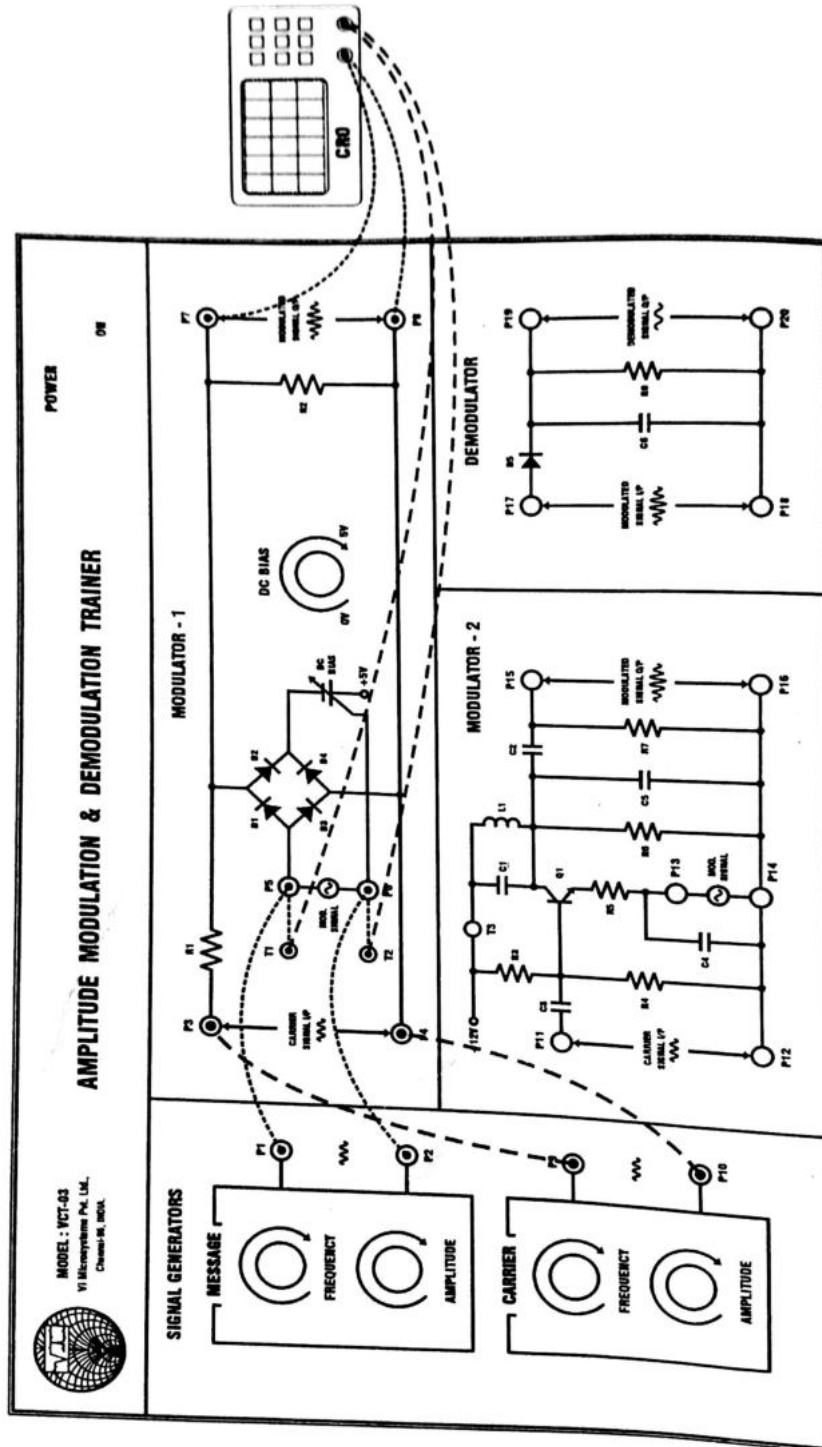

EC6512 – Communication Systems Laboratory

MODEL GRAPH:

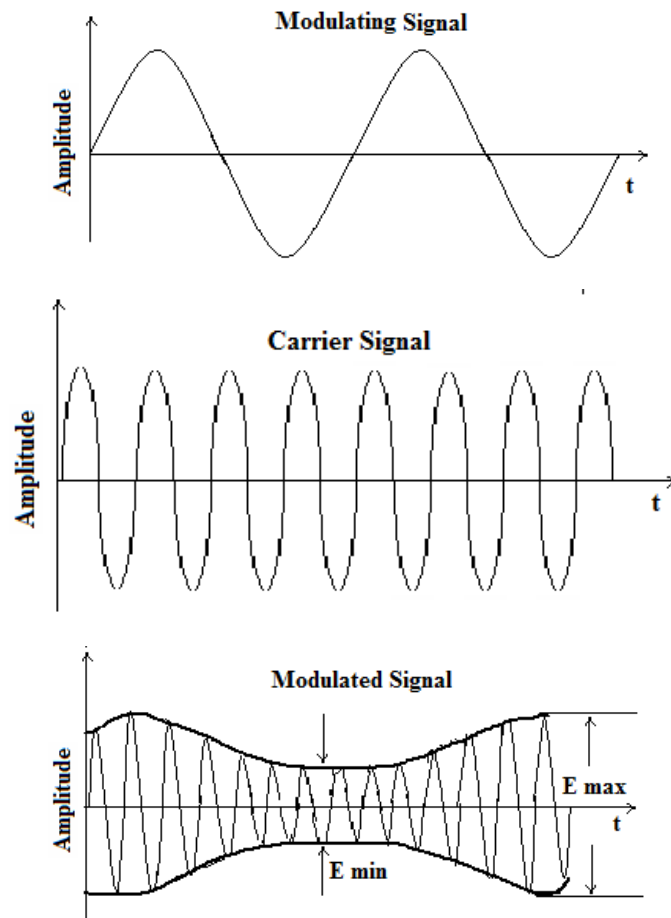

TABULATION:

Parameters	Amplitude Volts	Time period sec	Frequency Hz
Message Signal			
Carrier Signal			
Modulated Signal			
Demodulated Signal			

RESULT:

Thus the amplitude modulation and demodulation operation has been performed.

EC6512 – Communication Systems Laboratory

Exp. No.: 4

Date:

FREQUENCY MODULATION AND DEMODULATION

AIM:

To perform the frequency modulation and demodulation using FM kit.

APPARATUS REQUIRED:

1. Frequency modulation kit
2. DSO
3. Probes
4. Patch cords

THEORY:

Frequency modulation is a process of changing the frequency of a carrier wave in accordance with the slowly varying base band signal. The main advantage of this modulation is that it can provide better discrimination against noise.

PROCEDURE:

1. Connect the mains cord of the trainer unit to AC 220V, 50 Hz supply.
2. Switch ON the trainer kit. The neon lamp will glow indicating that the unit is ready for operation.
3. Observe the Modulating Signal in an Oscilloscope.
4. Observe the FM Source in the Oscilloscope.
5. Using patch cords, connect the FM Source to sockets marked 'FM INPUT' in FM Detector Circuit.
6. Observe the Frequency Demodulated Output Signal across sockets marked 'DEMOD OUTPUT'.

FUNCTIONAL BLOCK DIAGRAM:

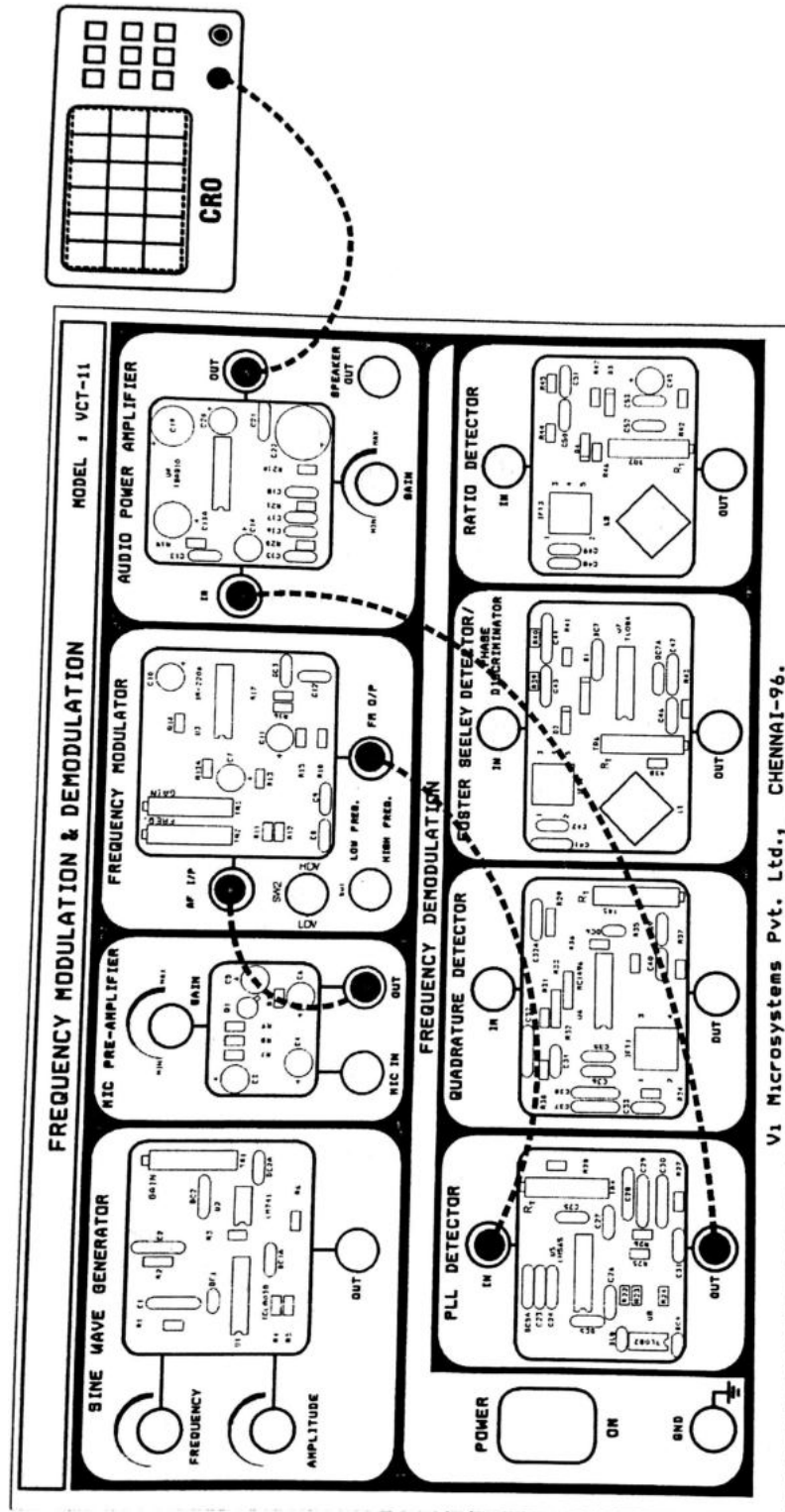

EC6512 – Communication Systems Laboratory

MODEL GRAPH:

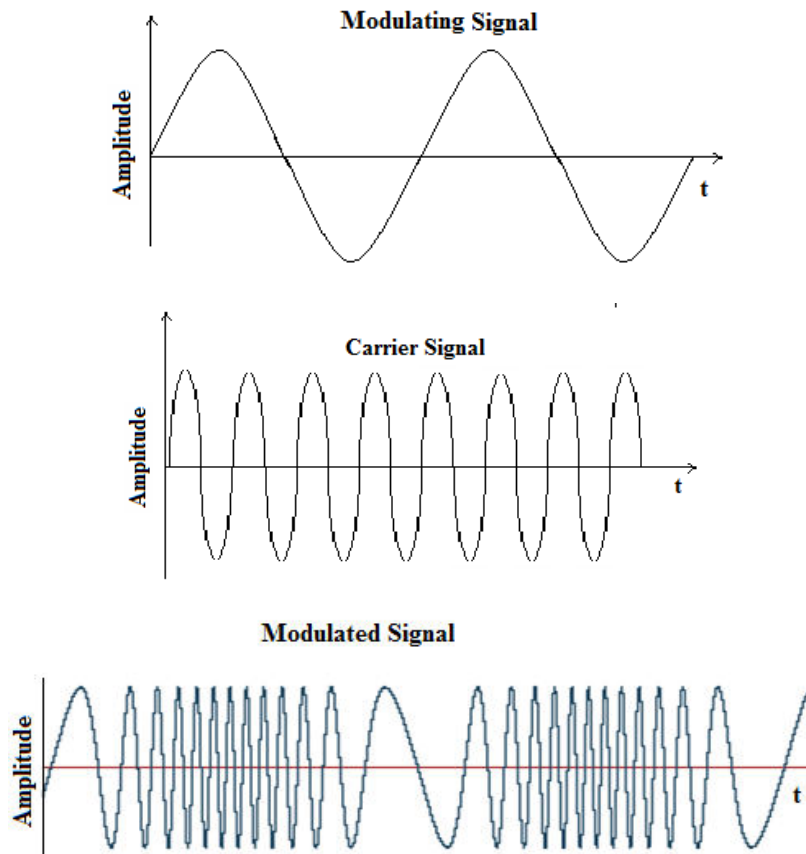

TABULATION:

Parameters	Amplitude Volts	Time period Sec	Frequency Hz
Message signal			
Carrier signal			
Modulated signal			
Demodulated signal			

RESULT:

Thus the frequency modulation and demodulation has been performed and also the modulation index was found.

EC6512 – Communication Systems Laboratory

Exp. No.: 5

Date:

PULSE CODE MODULATION AND DEMODULATION

AIM:

To perform Pulse code Modulation and demodulation and to plot the waveform for binary data at different frequencies

APPARATUS REQUIRED:

1. PCM kit
2. DSO
3. Probe
4. Patch cord

THEORY:

PCM is a method of converting an analog in to digital signals . Information in a analog form cannot be processes by digital computers so its necessary to convert them in to digital PCM is term which was formed during the development of digital audio transmission standards. Digital data can be transported robustly over long distances unlike the analog data and can be interleaved with other digital data sos various combinations of transmission channels can be used.

PROCEDURE:

- 1.Connect the mains cord of the trainer unit to AC 220V, 50 Hz supply.
- 2.Switch ON the trainer kit. The neon lamp will glow indicating that the unit is ready for operation.
- 3.Observe the Modulating Signal in an Oscilloscope.
- 4.Observe the FM Source in the Oscilloscope.
- 5.Using patch cords, connect sinewave signal source to the sample & hold circuits.
- 6.Connect the clock signal to the respective stages.
7. Observe the PCM output signal across the sockets marked “PCM OUTPUT”
8. Pulse mode modulated can also be observed by variable DC supply.

FUNCTIONAL BLOCK DIAGRAM:

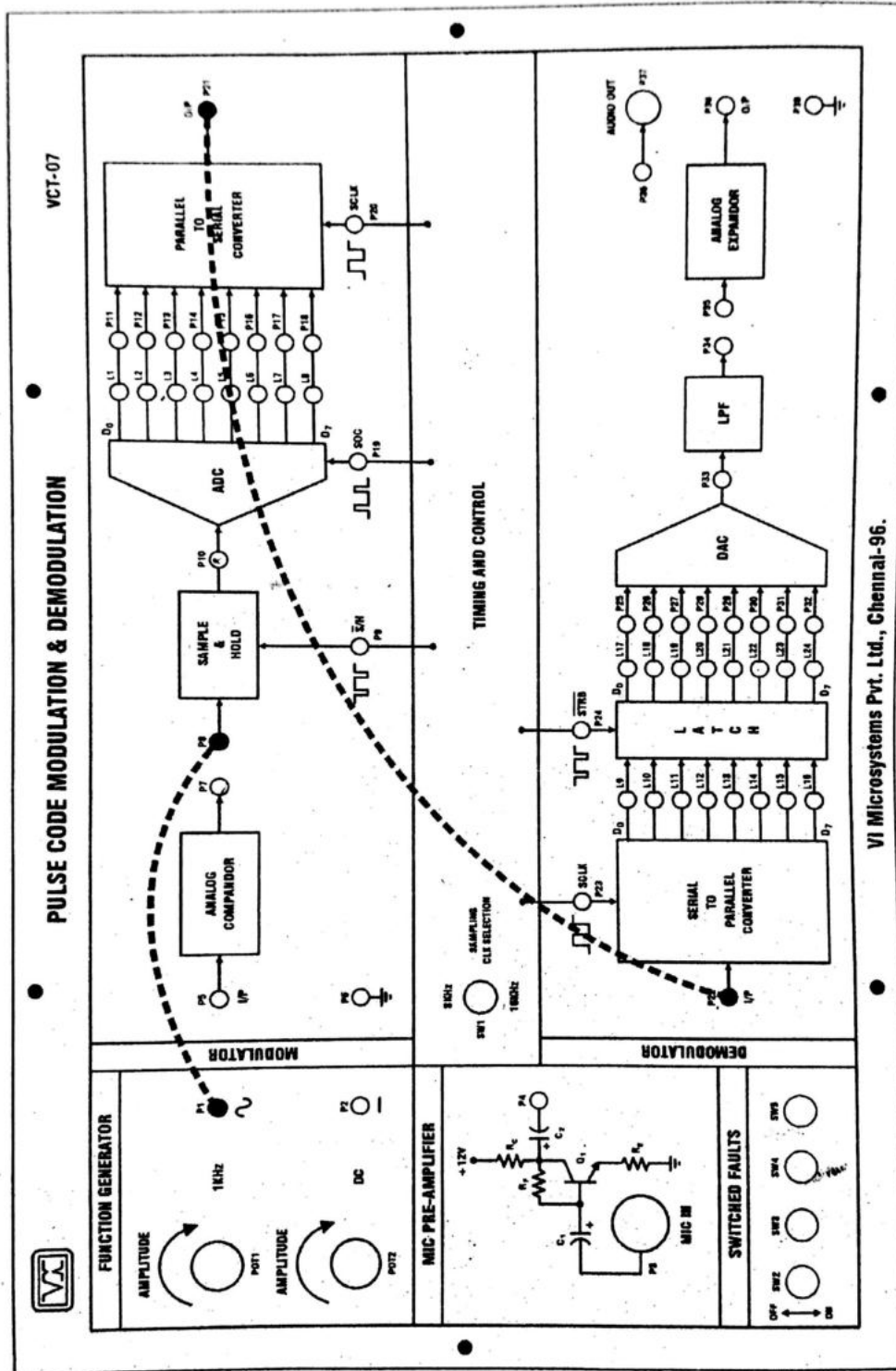

EC6512 – Communication Systems Laboratory

DEMODULATION:

1. Using patch cord connect the output from pulse code modulation to the sockets .
2. Observe the PCK demodulated output signal across the sockets marked “DEMODO OUTPUT”

BLOCK DIAGRAM:

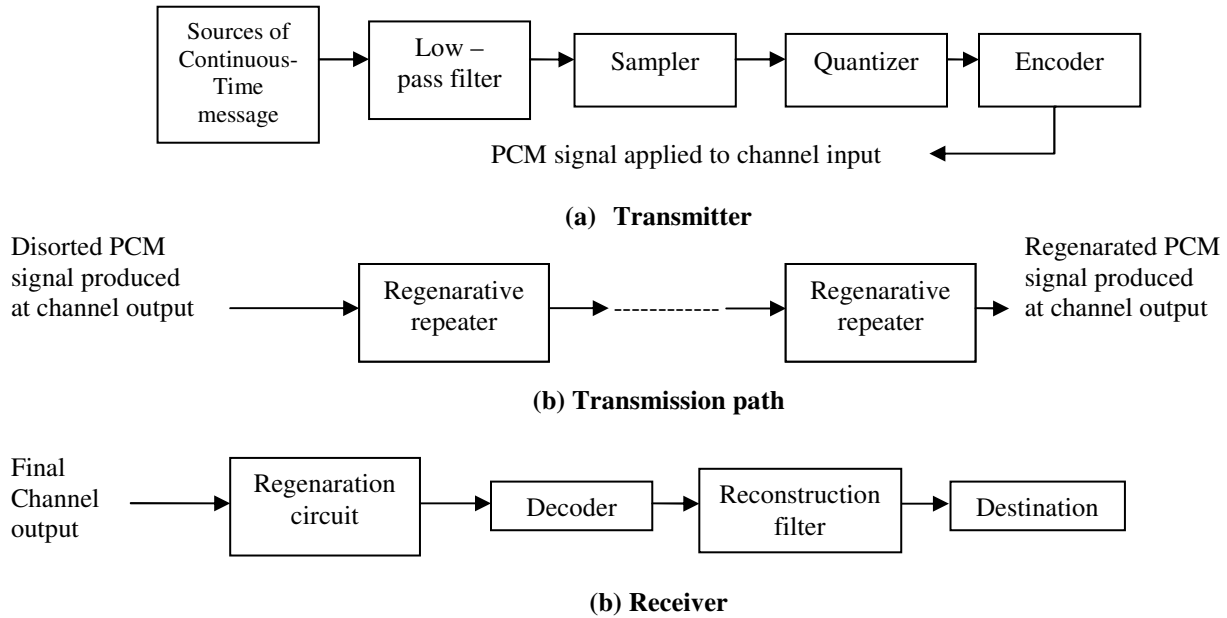

TABULATION:

Parameters	Amplitude Volts	Time period Sec	Frquency Hz
Message signal			
Modulated signal			
Demodulated signal			

RESULT:

Thus the Pulse Code Modulation and Demodulation was performed and output the verified.

EC6512 – Communication Systems Laboratory

Exp. No.: 6

Date:

DELTA MODULATION AND DEMODULATION

AIM:

To perform the Delta Modulation and Demodulation using hardware kit.

APPARATUS REQUIRED:

1. DM kit
2. DSO
3. Probe
4. Patch cord

THEORY:

Delta Modulation is a form of pulse modulation where a sample value is represented as a single bit. This is almost similar to differential PCM, as the transmitted bit is only one per sample just to indicate whether the present sample is larger or smaller than the previous one. The encoding, decoding and quantizing process become extremely simple but this system cannot handle rapidly varying samples. This increases the quantizing noise.

PROCEDURE:

A. Delta Modulation:

1. Connect the mains cord of the trainer unit to AC 220V, 50 Hz supply.
2. Switch ON the trainer kit. The neon lamp will glow indicating that the unit is ready for operation.
3. Observe the waveforms of Modulating Signal Generator and Clock Signal Generator in an Oscilloscope.
4. Using patch cords, connect the modulating signal to the sockets marked 'MOD SIGNAL' in the Delta Modulation.
5. Using patch cords, connect the clock signal to the sockets marked 'CLK' in the Signal Reconstructed.
6. Connect the 'DELTA MOD OUTPUT' in Delta Modulator to the sockets marked

EC6512 – Communication Systems Laboratory

'DELTA MOD INPUT' in the Signal Reconstructed.

7. Using patch cords, connect the Delta Reconstructed Output marked (#) from Signal reconstructed to the Delta Modulator marked (#).

B. Delta Demodulation:

1. Using patch cords, connect the 'DELTA RECONSTRUCTED OUTPUT' from the Signal.

2. Reconstructor to the sockets marked 'DELTA RECONSTRUCTED INPUT' in the Delta Demodulation.

3. Observe the demodulated output waveform across sockets marked 'DEMODO OUTPUT'.

BLOCK DIAGRAM OF DM MODULATOR AND DEMODULATOR:

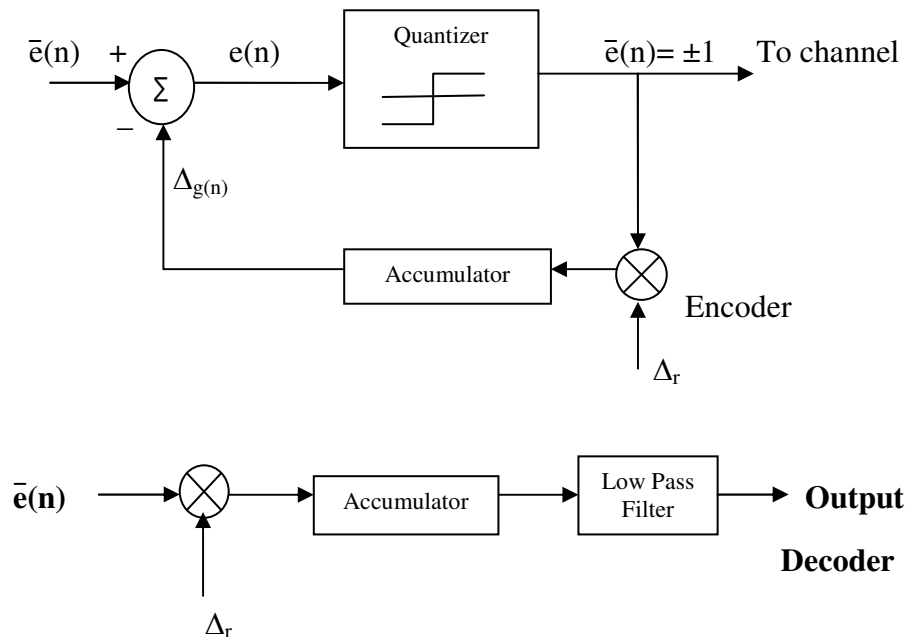

FUNCTIONAL BLOCK DIAGRAM:

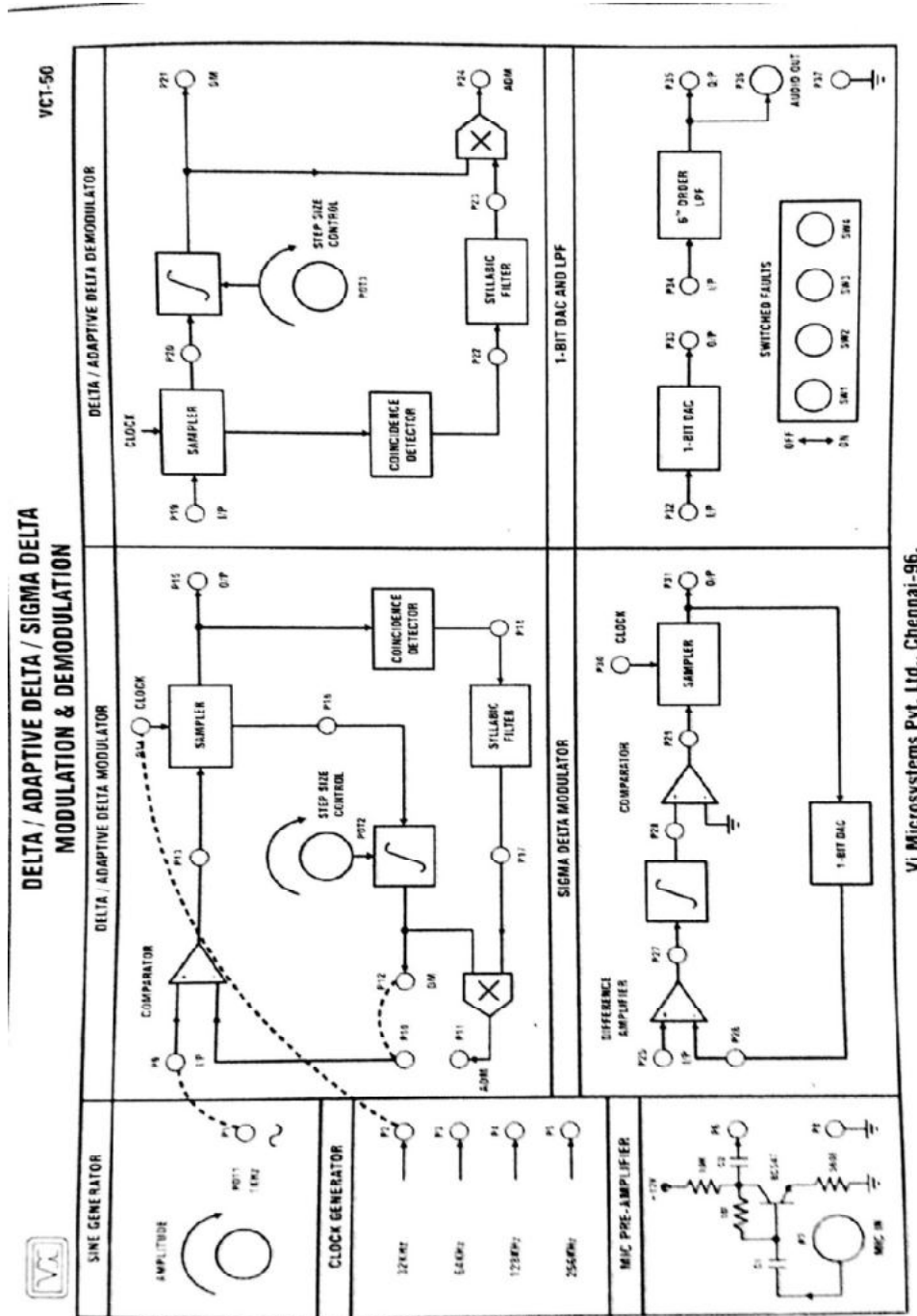

EC6512 – Communication Systems Laboratory

TABULATION:

Parameters	Amplitude Volts	Time period Sec	Frequency Hz
Message signal			
Demodulated signal			

MODEL GRAPH:

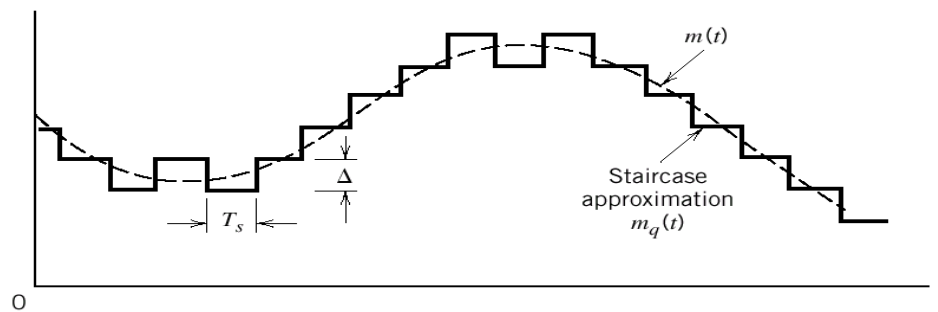

(a)

Binary
sequence
at modulator
output

0 0 1 0 1 1 1 1 1 0 1 0 0 0 0 0 0

(b)

RESULT:

Thus the Delta modulation and demodulation were performed and graph plotted.

EC6512 – Communication Systems Laboratory

Exp. No.: 7

Date:

OBSERVATION (SIMULATION) OF SIGNAL CONSTELLATIONS OF BPSK, QPSK AND QAM

AIM:

To simulate BPSK QPSK and QAM using MAT Lab .

APPARATUS REQUIRED:

1. Personal Computer
2. Matlab software R2014a

PROCEDURE:

1. Open Matlab version R2014a
2. Open new file and enter the program and save it.
3. Add the path to the location of the file in the system.
4. Compile the program and check for any error and debug it.
5. Note down the output.

MATLAB CODING:

BPSK:

```
clc;
clear all;
bits=1000000;
data=randint (1,bits)>0.5;
ebno=0:10;
BER=zeros(1,length(ebno));
for i=1:length(ebno)
    %---Transmitter-----
    %mapping of bits into symbols
    symb=2.*data-1;
    %----Filter
    psf=ones(1,1);
    M=length(psf);
    % inserting zeros between the bits
    % w.r.t number of coefficients of
```

```

% PSF to pass the bit stream from the PSF
    z=zeros(M-1,bits);
upsamp=[symb;z];
    upsamp2=reshape(upsamp,1,(M)*bits);
    %Passing the symbols from PSF
    tx_symb=conv(upsamp2,psf);
    %-----CHANNEL-----
    %Random noise generation and addition to the signal
    ebno=10.^(ebno(i)/10);
    n_var=1/sqrt(2.*ebno);
    rx_symb=tx_symb+n_var*randn(1,length(tx_symb));
    %XXXXXXXXXXXXXXXXXXXXXXXXXXXX
    %-----RECEIVER-----
    rx_match=conv(rx_symb,psf);
    rx=rx_match(M:M:length(rx_match));
    rx=rx(1:1:bits);
    recv_bits=(sign(rx)+1)./2;
    %XXXXXXXXXXXXXXXXXXXXXXXXXXXX
    %---SIMULATED BIT ERROR RATE----
    errors=find(xor(recv_bits,data));
    errors=size(errors,2);
    BER(i)=errors/bits;
    %XXXXXXXXXXXXXXXXXXXXXXXXXXXX
end
fs=1;
n_pt=2^9;
tx_spec=fft(tx_symb,n_pt);
f=-fs/2:fs/n_pt:fs/2-fs/n_pt;
figure
plot(f,abs(fftshift(tx_spec)));
title('Signal Spectrum for Signal with Rectangular Pulse
Shaping for BPSK');
xlabel('Frequency [Hz]');
ylabel('x(F)');
figure
semilogy(ebno,BER,'b.-');
hold on
thr=0.5*erfc(sqrt(10.^(ebno/10)));
semilogy(ebno,thr,'rx-');

xlabel('Eb/No (dB)')
ylabel('Bit Error rate')
title('Simulated Vs Theoretical Bit Error Rate for BPSK')
legend('simulation','theory')
grid on;

```



```

%-----RECEIVER-----
rx_match=conv(rx_symb,psf);
rx=rx_match(M:M:length(rx_match));
rx=rx(1:1:bits/2);
recv_bits=zeros(1,bits);
%demapping
k=1;
for ii=1:bits/2
    recv_bits(k)= -( sign( real( rx(ii))) -1)/2;
    recv_bits(k+1)=- ( sign( imag( rx(ii)))-1)/2;
    k=k+2;
end
    %sign( real( rx ) )
%sign( imag( rx ) )
    %data
    %tx_symb
    %rx_symb

    %recv_bits
%XXXXXXXXXXXXXXXXXXXXXXXXXXXXX
%---SIMULATED BIT ERROR RATE----

    errors=find(xor(recv_bits,data));
errors=size(errors,2);
BER(i)=errors/bits;
%XXXXXXXXXXXXXXXXXXXXXXXXXXXXX
end
fs=1;
n_pt=2^9;
tx_spec=fft(tx_symb,n_pt);
f= -fs/2:fs/n_pt:fs/2-fs/n_pt;
figure
plot(f,abs(fftshift(tx_spec)));
title('Signal Spectrum for Signal with Rectangular
Pulse Shaping for QPSK');
xlabel('Frequency [Hz]');
ylabel('x(F)');
figure
semilogy(ebno,BER,'b.-');
hold on
thr=0.5*erfc(sqrt(10.^(ebno/10)));
semilogy(ebno,thr,'rx-');
xlabel('Eb/No (dB)')
ylabel('Bit Error rate')
title('Simulated Vs Theoretical Bit Error Rate for
QPSK')
legend('Simulation','Theory'; grid on;

```

QAM:

```
clc
clear all
bits=3000000;
data=randint(1,bits)>0.5;
%---debugging---
%data=[1 1 1]
%xxxxxxxxxxx
ebno=0:10;
BER=zeros(1,length(ebno));
thr=BER;
%---Transmitter-----
%Gray mapping of bits into symbols

col=length(data)/3;
I=zeros(1,col);
Q=I;
k=1;
for i=1:3:length(data)
    if(data(i:i+2)==[0 0 0])
        I(k)=1;
        Q(k)=1;
        k=k+1;
    elseif(data(i:i+2)==[0 0 1])
        I(k)=3;
        Q(k)=1;
        k=k+1;
    elseif(data(i:i+2)==[0 1 0])
        I(k)=-1;
        Q(k)=1;
        k=k+1;
    elseif(data(i:i+2)==[0 1 1])
        I(k)=-3;
        Q(k)=1;
        k=k+1;
    elseif(data(i:i+2)==[1 0 0])
        I(k)=1;
        Q(k)=-1;
        k=k+1;
    elseif(data(i:i+2)==[1 0 1])

        I(k)=3;
        Q(k)=-1;
        k=k+1;
    elseif(data(i:i+2)==[1 1 0])
        I(k)=-1;
        Q(k)=-1;
```

```

        k=k+1;
    elseif(data(i:i+2)==[1 1 1])

        I(k)=-3;
        Q(k)=-1;
        k=k+1;
    end
end
symb=I+j*Q;
%real(symb)
%imag(symb)

%----Filter
psf=ones(1,1);
Es=sum(psf.^2);
eb=Es/3;
eb=2;
%----
M=length(psf);
for i=1:length(ebno)
    % inserting zeros between the bits
    % w.r.t number of coefficients of
    % PSF to pass the bit stream from the PSF
    z=zeros(M-1, bits/3);
    upsamp=[symb; z];
    upsamp2=reshape(upsamp,1, (M)*bits/3);
    %Passing the symbols from PSF

%tx_symb=conv(real(upsamp2),psf)+j*conv(imag(upsamp2),psf);
    tx_symb=conv(upsamp2,psf);
%-----CHANNEL-----
%Random noise generation and addition to the signal
ebno2=10.^(ebno(i)/10);
%no=eb/ebno2;
%n_var=sqrt(no/2);
n_var=sqrt(eb/(2*ebno2));
    rx_symb=tx_symb+(n_var*randn(1,length(tx_symb))
+j*n_var*randn(1,length(tx_symb)));
%XXXXXXXXXXXXXXXXXXXXXXXXXXXXXXXXXXXX
%-----RECEIVER-----
    rx_match=conv(rx_symb,psf);
    rx=rx_match(M:M:length(rx_match));
    rx=rx(1:1:bits/3);
    recv_bits=zeros(1, bits);
    %demapping
    k=1;
    for n=1:bits/3
        I=real(rx(n));

```

```

    Q=imag(rx(n));
    if (I > 0) && (I < 2) && (Q > 0)
        recv_bits(k:k+2)=[0 0 0];
    elseif (I > 0) && (I < 2) && (Q < 0)
        recv_bits(k:k+2)=[1 0 0];
    elseif (I > 2) && (Q > 0)
        recv_bits(k:k+2)=[0 0 1];
    elseif (I > 2) && (Q < 0)
        recv_bits(k:k+2)=[1 0 1];
    elseif (I < 0) && (I > -2) && (Q > 0)
        recv_bits(k:k+2)=[0 1 0];
    elseif (I < 0) && (I > -2) && (Q < 0)
        recv_bits(k:k+2)=[1 1 0];
    elseif (I < -2) && (Q > 0)
        recv_bits(k:k+2)=[0 1 1];
    elseif (I < -2) && (Q < 0)
        recv_bits(k:k+2)=[1 1 1];
    end
    k=k+3;
end
tx_symb;
rx_symb;
data;
recv_bits;
%XXXXXXXXXXXXXXXXXXXXXXXXXXXXXXXXXXXX
%---SIMULATED BIT ERROR RATE----
errors=find(xor(recv_bits,data));
errors=size(errors,2);
BER(i)=errors/bits;
ebno_lin=(10^(ebno(i)/10))
thr(i)=(5/12)*erfc(sqrt(ebno_lin/2));
%XXXXXXXXXXXXXXXXXXXXXXXXXXXXXXXXXXXX
end
fs=1;
n_pt=2^9;
tx_spec=fft(tx_symb,n_pt);
f= -fs/2:fs/n_pt:fs/2-fs/n_pt;
figure
plot(f,abs(fftshift(tx_spec)));
title('Signal Spectrum for Signal with Rectangular
Pulse Shaping for 8QAM');
xlabel('Frequency [Hz]');
ylabel('x(F)');
figure;
semilogy(ebno,BER,'b.-');
hold on
%ebno2=(10.^(ebno/10));

```

EC6512 – Communication Systems Laboratory

```
%thr=(5/12).*erfc(sqrt((10.^(ebno/10))./2));  
semilogy(ebno,thr,'rx-');  
xlabel('Eb/No (dB)')  
ylabel('Bit Error rate')  
title('Simulated Vs Theoretical Bit Error Rate for 8-QAM')  
legend('Simulation','Theory'); grid on;
```

SIMULATED VS THEORTICAL BIT ERROR RATE FOR BPSK:

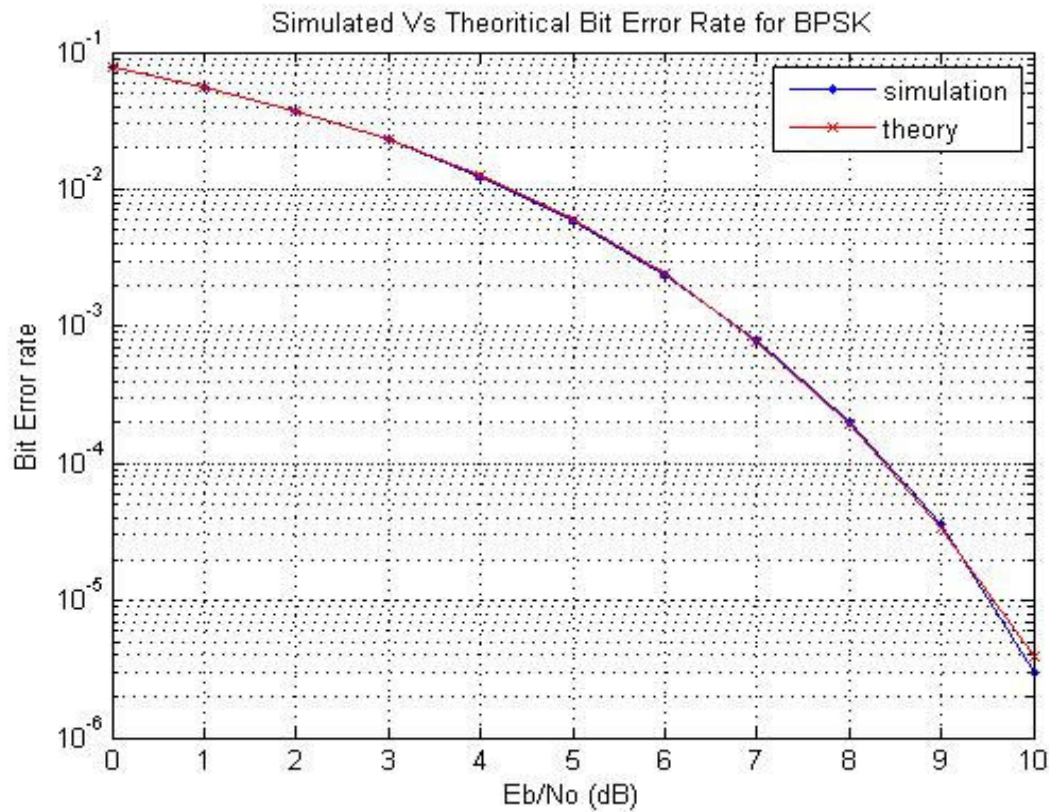

RECTANGULAR PULSE SHAPING FOR BPSK:

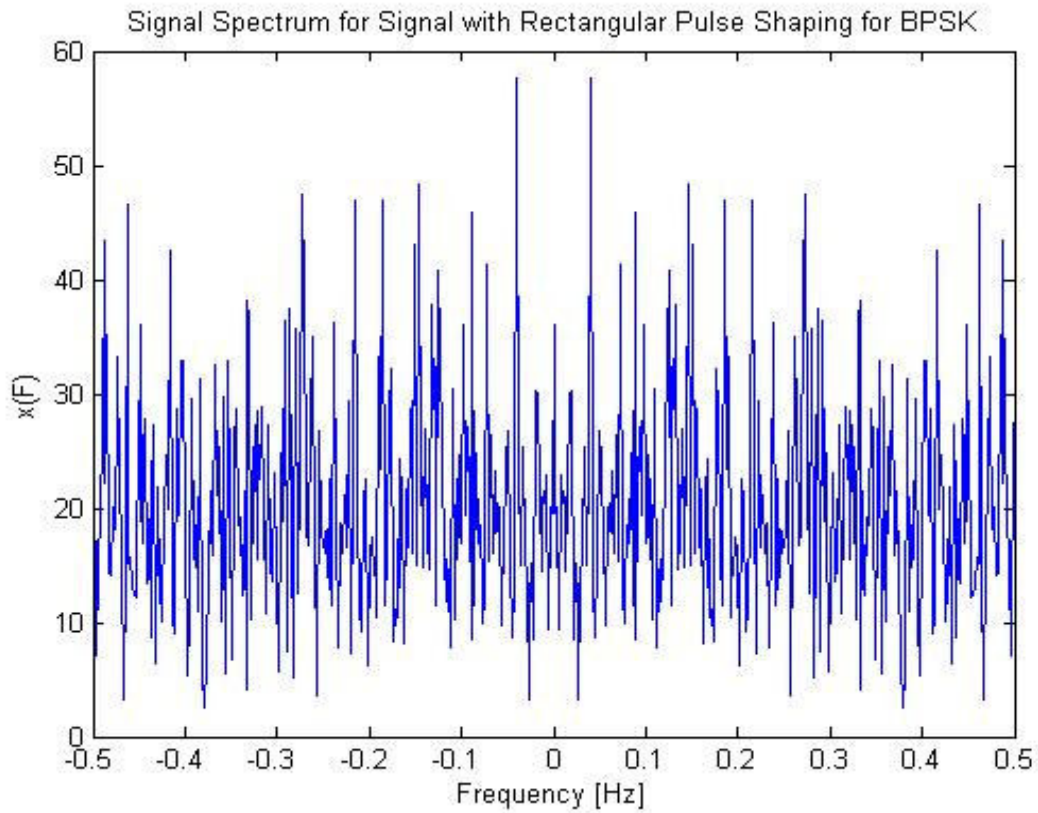

SIMULATED VS THEORITICAL BIT ERROR RATE FOR QPSK:

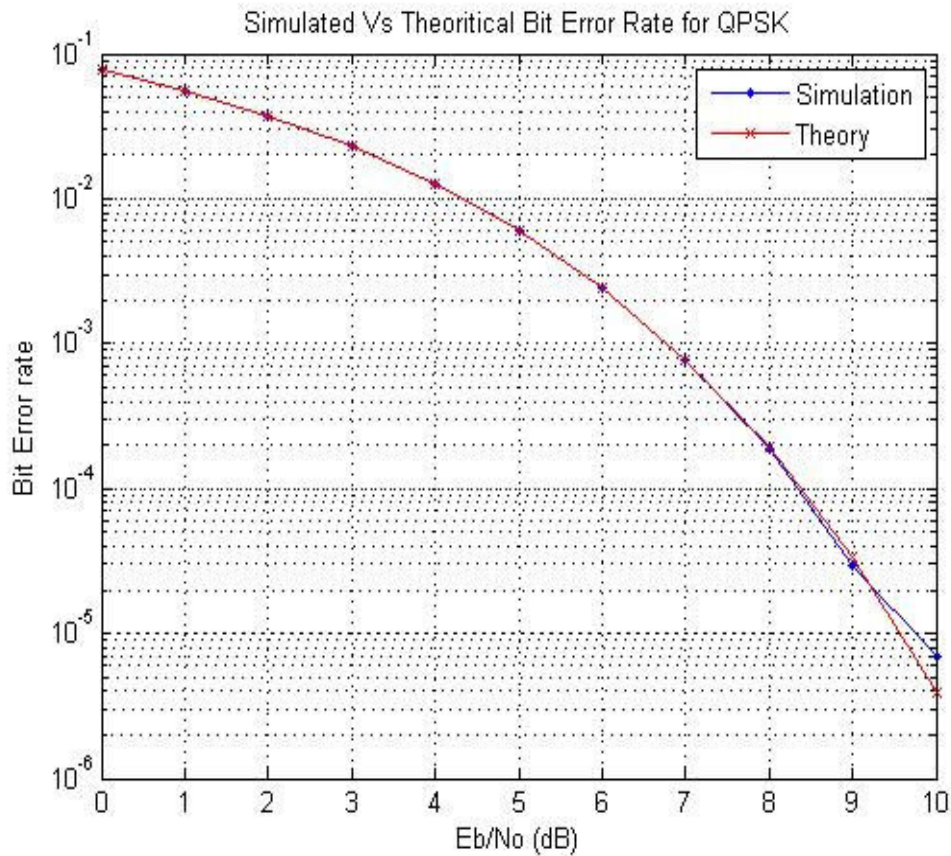

SIGNAL SPECTRUM FOR SIGNAL WITH RECTANGULAR PULSE SHAPING FOR QPSK:

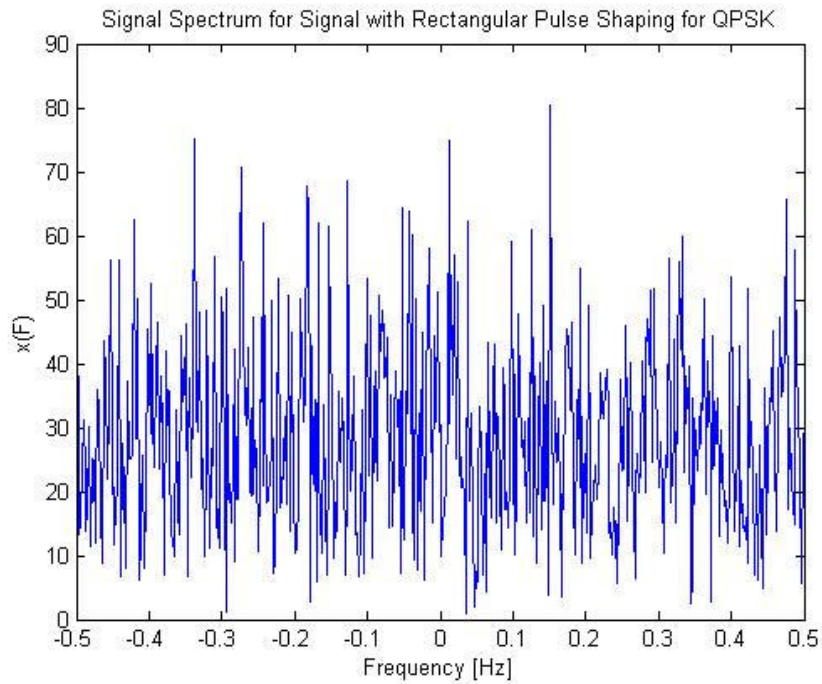

SIGNAL SPECTRUM FOR SIGNAL WITH RECTANGULAR PULSE SHAPING FOR 8 QAM:

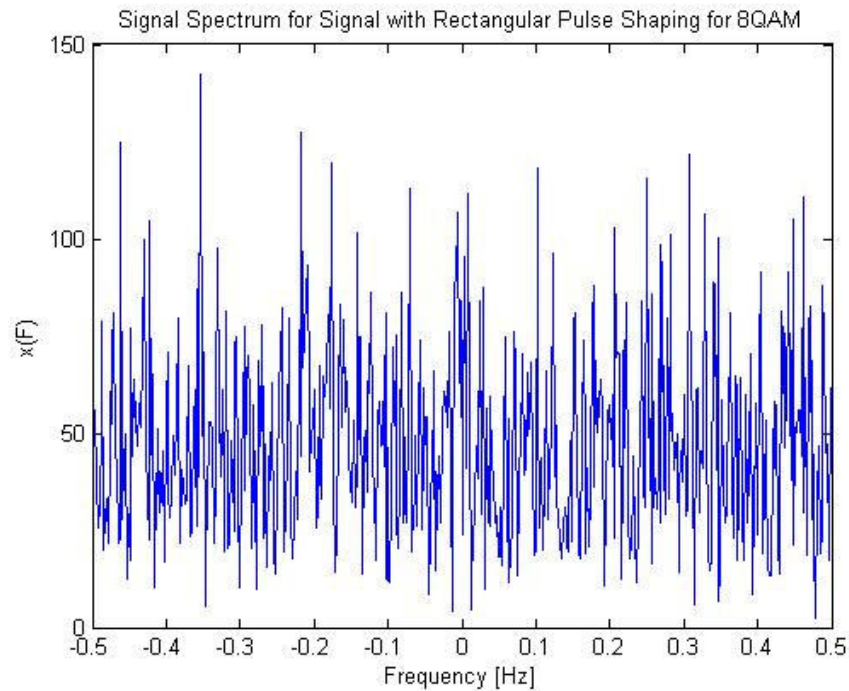

SIMULATED VS THEORITICAL BIT ERROR RATE FOR 8- QAM:

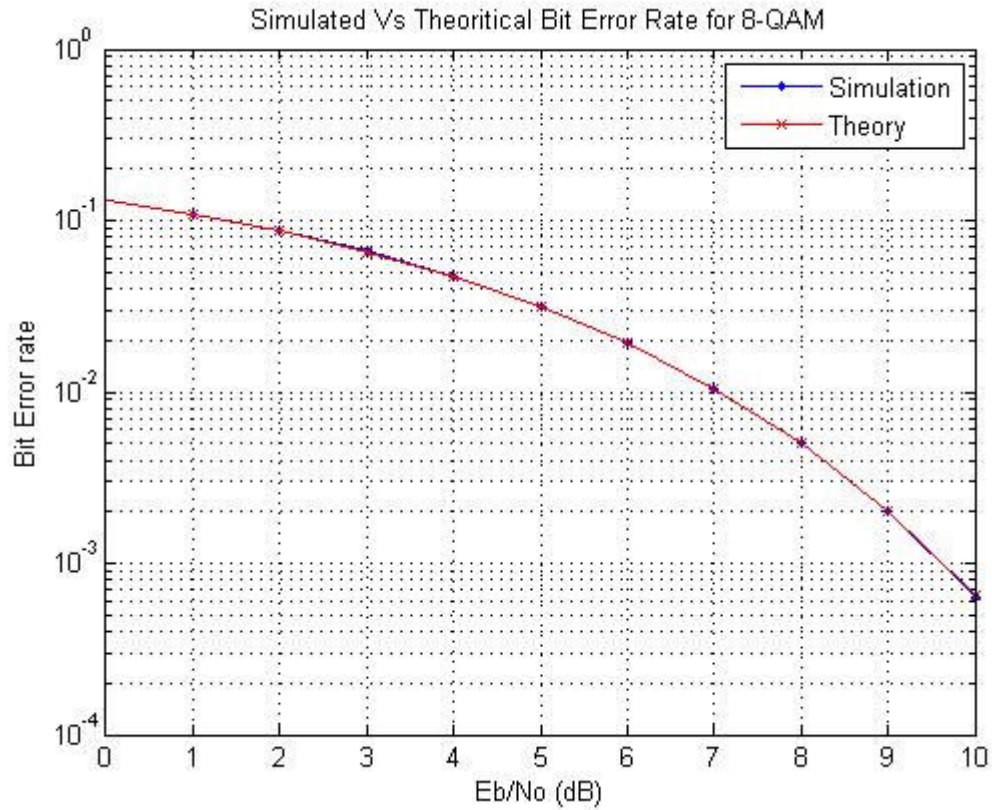

RESULT:

Thus the Signal Constellation of BPSK, QPSK and QAM were plotted.

EC6512 – Communication Systems Laboratory

Exp. No.: 8

Date:

LINE CODING AND DECODING TECHNIQUES

AIM:

1. To study the different line coding techniques with the communication trainer kit

APPARATUS REQUIRED:

2. Communication trainer kit.
3. Patch cords.
4. DSO/CRO

THEORY:

Line coding refers to the process of representing the bit stream (1's and 0's) in the form of voltage or current variations optimally tuned for the specific properties of the physical channel being used. The selection of a proper line code can help in so many ways: One possibility is to aid in clock recovery at the receiver.

Some common types of line encoding in common-use nowadays are unipolar, polar, bipolar, Manchester and Duobinary encoding. These codes are explained here:

Unipolar (Unipolar NRZ and Unipolar RZ):

Unipolar is the simplest line coding scheme possible. It has the advantage of being compatible with TTL logic. Unipolar coding uses a positive rectangular pulse $p(t)$ to represent binary 1, and the absence of a pulse (i.e., zero voltage) to represent a binary 0. Two possibilities for the pulse $p(t)$ exist: Non-Return-to-Zero (NRZ) rectangular pulse and Return-to-Zero (RZ) rectangular pulse. The difference between Unipolar NRZ and Unipolar RZ codes is that the rectangular pulse in NRZ stays at a positive value (e.g., +5V) for the full duration of the logic 1 bit, while the pulse in RZ drops from +5V to 0V in the middle of the bit time.

A drawback of unipolar (RZ and NRZ) is that its average value is not zero, which means it creates a significant DC-component at the receiver (see the impulse at zero frequency in the corresponding power spectral density (PSD) of this line code).

EC6512 – Communication Systems Laboratory

MANCHESTER ENCODING:

In Manchester code each bit of data is signified by at least one transition. Manchester encoding is therefore considered to be self-clocking, which means that accurate clock recovery from a data stream is possible. In addition, the DC component of the encoded signal is zero. Although transitions allow the signal to be self-clocking, it carries significant overhead as there is a need for essentially twice the bandwidth of a simple NRZ or NRZI encoding

- Ø Unipolar most of signal power is centered around origin and there is waste of power due to DC component that is present.
- Ø Polar format most of signal power is centered around origin and they are simple to implement.
- Ø Bipolar format does not have DC component and does not demand more bandwidth, but power requirement is double than other formats.
- Ø Manchester format does not have DC component but provides proper clocking.

PROCEDURE:

1. Connect the PRBS (test point P5) to various line coding formats. Obtain the coded output as per the requirement.
2. Connect coded signal test point to corresponding decoding test point as inputs.
3. Set the SW1 as per the requirement.
4. Set the potentiometer P1 in minimum position.
5. Switch ON the power supply. Press the switch SW2 once.
6. Display the encoded signal and decoded signal on the cro

FUNCTIONAL BLOCK DIAGRAM:

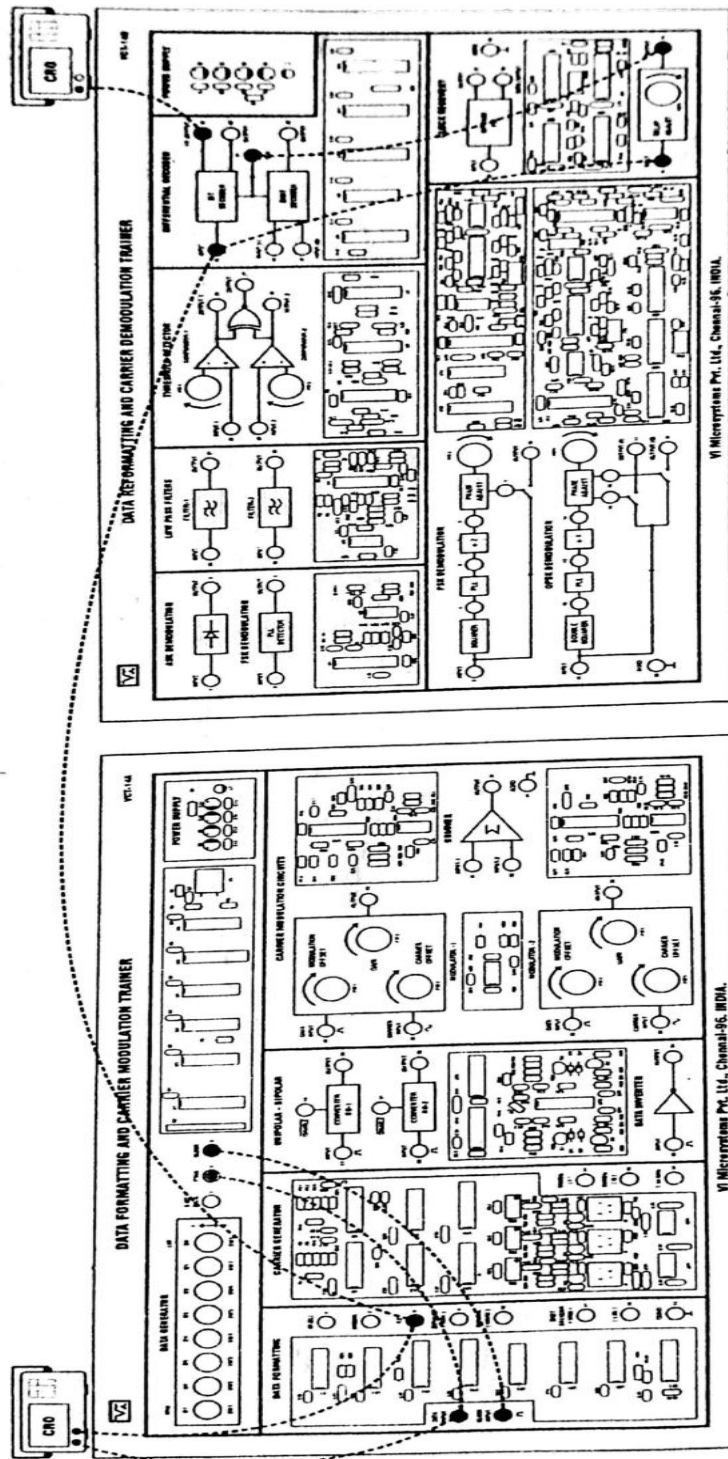

EC6512 – Communication Systems Laboratory

TABULAR COLUMN:

S.no	Name of the Signal	Amplitude Volt	Time period Sec	Frequency Hz

MODEL GRAPH:

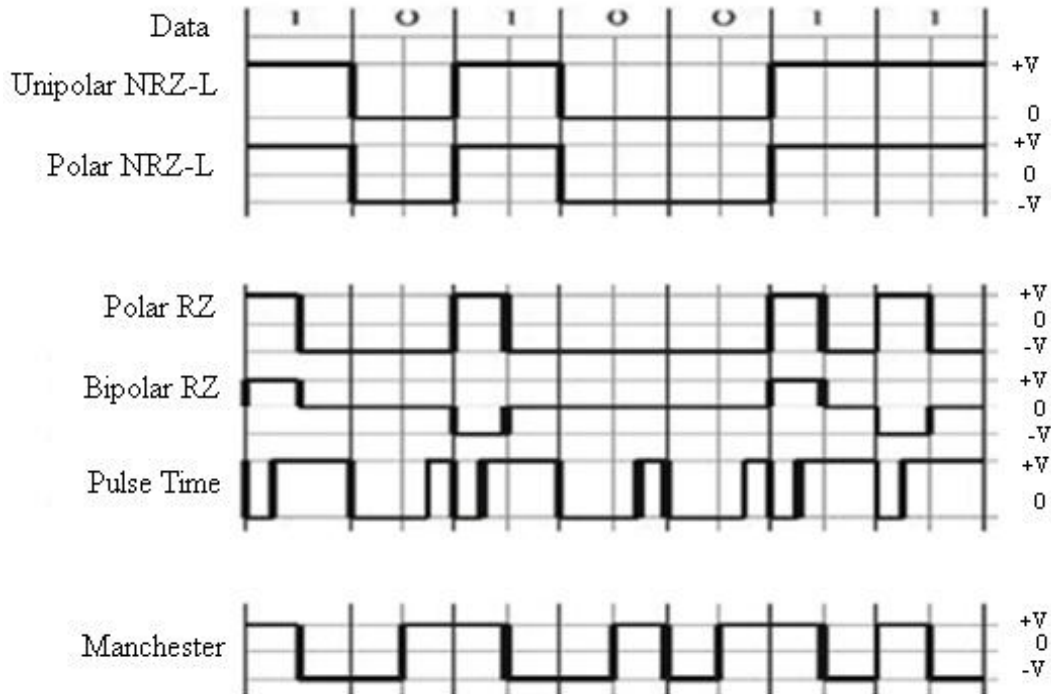

RESULT:

Thus the line coding and decoding techniques was studied

EC6512 – Communication Systems Laboratory

Exp. No.: 9

Date:

ASK, FSK AND PSK SIMULATION USING MATLAB

AIM:

To simulate ASK, FSK and PSK using matlab.

APPARATUS REQUIRED:

1. Personal Computer
2. Matlab software R2014a

PROCEDURE:

1. Open Matlab version R2014a.
2. Open new file and enter the program and save it.
3. Add the path to the location of the file in the system.
4. Compile the program and check for any error and debug it.
5. Note down the output.

MATLAB CODING:

ASK, FSK & PSK:

```
%matlab code for digital modulation (ask, fsk and psk)
pi=3.14;
f=5;
f2=10;
phi=pi;

x=[1 0 1 1 0];
nx=size(x,2);

i=1;
while i<nx+1
    t = i:0.001:i+1;
    if x(i)==1
        ask=sin(2*pi*f*t);
        fsk=sin(2*pi*f*t);
        psk=sin(2*pi*f*t);
    else
        ask=0;
        fsk=sin(2*pi*f2*t);
```

EC6512 – Communication Systems Laboratory

```
psk=sin(2*pi*f*t+phi);
end

subplot(3,1,1);
plot(t,ask);
xlabel('time')
ylabel('amplitude')
title('amplitude shift keying')
holdon;
gridon;
axis([1 10 -2 2]);

subplot(3,1,2);
plot(t,fsk);
xlabel('time')
ylabel('amplitude')
title('frequency shift keying')
holdon;
gridon;
axis([1 10 -2 2]);

subplot(3,1,3);
plot(t,psk);
xlabel('time')
ylabel('amplitude')
title('Phase shift keying')
holdon;
gridon;
axis([1 10 -2 2]);

    i=i+1;
end
```

MODEL GRAPH:

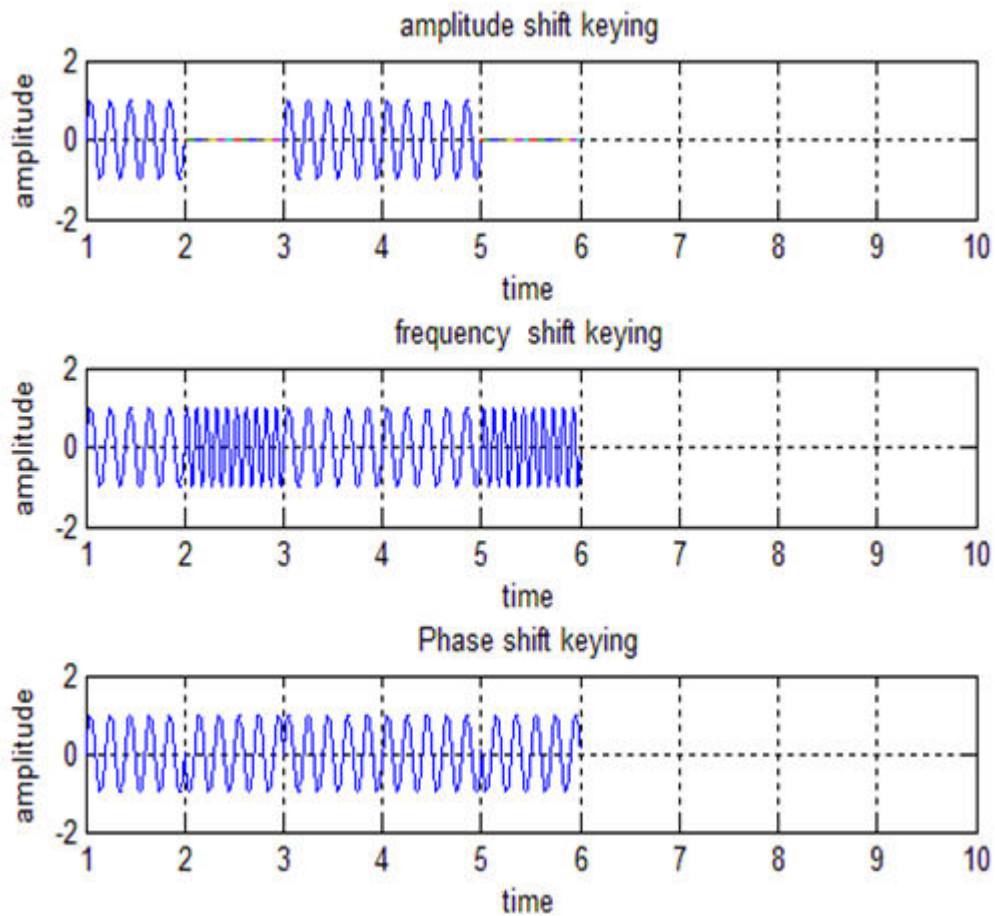

RESULT:

The simulation of ASK FSK and PSK has been done using MATLAB and the outputs were recorded.

EC6512 – Communication Systems Laboratory

Exp. No.: 10

Date:

ERROR CONTROL CODING

AIM:

To study error linear block code error control coding technique using MATLAB.

APPARATUS REQUIRED:

1. Personal Computer
2. Matlab software R2014a

THEORY:

In coding theory, a linear code is an error-correcting code for which any linear combination of codewords is also a codeword. Linear codes are traditionally partitioned into block codes and convolutional codes, although turbo codes can be seen as a hybrid of these two types. Linear codes allow for more efficient encoding and decoding algorithms than other codes. Linear codes are used in forward error correction and are applied in methods for transmitting symbols (e.g., bits) on a communications channel so that, if errors occur in the communication, some errors can be corrected or detected by the recipient of a message block.

PROCEDURE:

1. Open Matlab version R2014a
2. Open new file and enter the program and save it.
3. Add the path to the location of the file in the system.
4. Compile the program and check for any error and debug it.
5. Note down the output.

MATLAB CODING:

```
clc;clearall;
%g=input('Enter The Generator Matrix: ');%row value
separate by semicolon
disp('The Generator Matrix is : ');
g= [1 1 0 1 0 0 0 ;0 1 1 0 1 0 0;1 1 1 0 0 1 0;1 0 1 0 0 0
1];
disp(g);
disp ('The Order of Linear Block Code for given Generator
Matrix is:');
[n,k] = size(transpose(g));
disp('The Code Word Length is : ');disp(n);
```

```
disp('The Parity Bit Length is : ');disp(k);
for i = 1:2^k
for j = k:-1:1
if rem(i-1,2^(-j+k+1))>=2^(-j+k)
m(i,j)=1;
else
m(i,j)=0;
end
end
end
disp('The Possible Message Bits are : ');
disp('      c0      c1      c2      c3');
disp(m);
disp('The Possible Codewords are :')
disp('      b0      b1      b2      c0      c1      c2      c3      Hamming
weight')
c = rem(m*g,2);
d_min = sum((c(1:2^k,:))');
d_min2=d_min';
s= [ c d_min2];
disp(s);
disp('The Minimum Hamming Weight for the given Block Code
is= ');
d_min1 = min(sum((c(2:2^k,:))'));
disp(d_min1);
% DECode
p = [g(:,1:n-k)];
h = [eye(n-k),transpose(p)];

disp('The H Matrix is ');
disp(h);
ht = transpose(h);
disp('The H Transpose Matrix is ');
disp(ht);
r=[0 0 1 1 1 0 1];
e=rem(r*ht,2);
disp('Syndrome of a Given Codeword is :');
disp(e);
for i = 1:1:size(ht)
if(ht(i,1:3)==e)
r(i) = 1-r(i);
break;
end
end
disp('The Error is in bit:');
disp(i);
disp('The Corrected Codeword is :');disp(r);
```

EC6512 – Communication Systems Laboratory

OUTPUT:

The Generator Matrix is :

1	1	0	1	0	0	0
0	1	1	0	1	0	0
1	1	1	0	0	1	0
1	0	1	0	0	0	1

The Order of Linear Block Code for given Generator Matrix is:

The Code Word Length is : 7

The Parity Bit Length is : 4

The Possible Message Bits are :

c0	c1	c2	c3
0	0	0	0
0	0	0	1
0	0	1	0
0	0	1	1
0	1	0	0
0	1	0	1
0	1	1	0
0	1	1	1
1	0	0	0
1	0	0	1
1	0	1	0
1	0	1	1
1	1	0	0
1	1	0	1
1	1	1	0
1	1	1	1

The Possible Codewords are :

b0	b1	b2	c0	c1	c2	c3	Hamming weight
0	0	0	0	0	0	0	0
1	0	1	0	0	0	1	3
1	1	1	0	0	1	0	4
0	1	0	0	0	1	1	3
0	1	1	0	1	0	0	3
1	1	0	0	1	0	1	4
1	0	0	0	1	1	0	3
0	0	1	0	1	1	1	4
1	1	0	1	0	0	0	3
0	1	1	1	0	0	1	4

EC6512 – Communication Systems Laboratory

0	0	1	1	0	1	0	3
1	0	0	1	0	1	1	4
1	0	1	1	1	0	0	4
0	0	0	1	1	0	1	3
0	1	0	1	1	1	0	4
1	1	1	1	1	1	1	7

The Minimum Hamming Weight for the given Block Code is= 3

The H Matrix is

1	0	0	1	0	1	1
0	1	0	1	1	1	0
0	0	1	0	1	1	1

The H Transpose Matrix is

1	0	0
0	1	0
0	0	1
1	1	0
0	1	1
1	1	1
1	0	1

Syndrome of a Given Codewordis :

0	0	1
---	---	---

The Error is in bit: 3

The Corrected Codewordis :

0	0	0	1	1	0	1
---	---	---	---	---	---	---

RESULT:

Thus the program for error control coding was done using MATLAB and the output verified.

EC6512 – Communication Systems Laboratory

Exp. No.: 11

Date:

COMMUNICATION LINK

AIM:

To simulate the communication link using MATLAB simulation tool.

APPARATUS REQUIRED:

1. Personal Computer
2. Matlab software R2014a

PROCEDURE:

1. Open Matlab version R2014a.
2. And click the start button.
3. Now select the simulink library browser.
4. Open new file for a new project and fix the tools from the simulink library browser, the connect the all tools and save it.
5. Now press run button for to simulate communication link.
6. Note down the output.

SIMULINK DIAGRAM OF COMMUNICATION LINK:

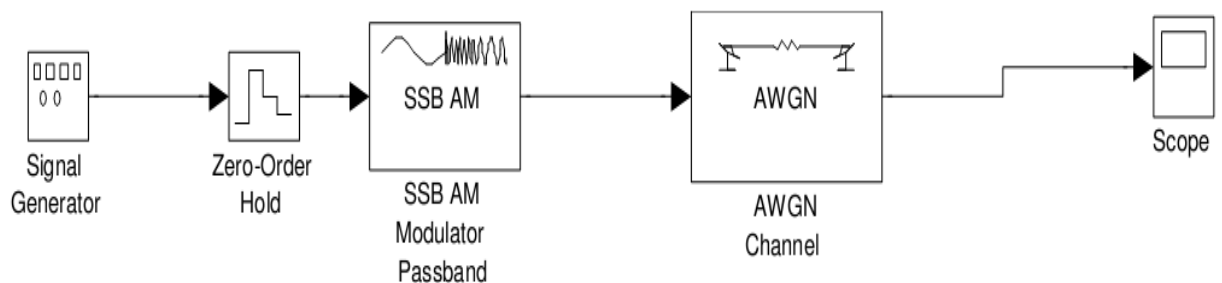

OUTPUT:

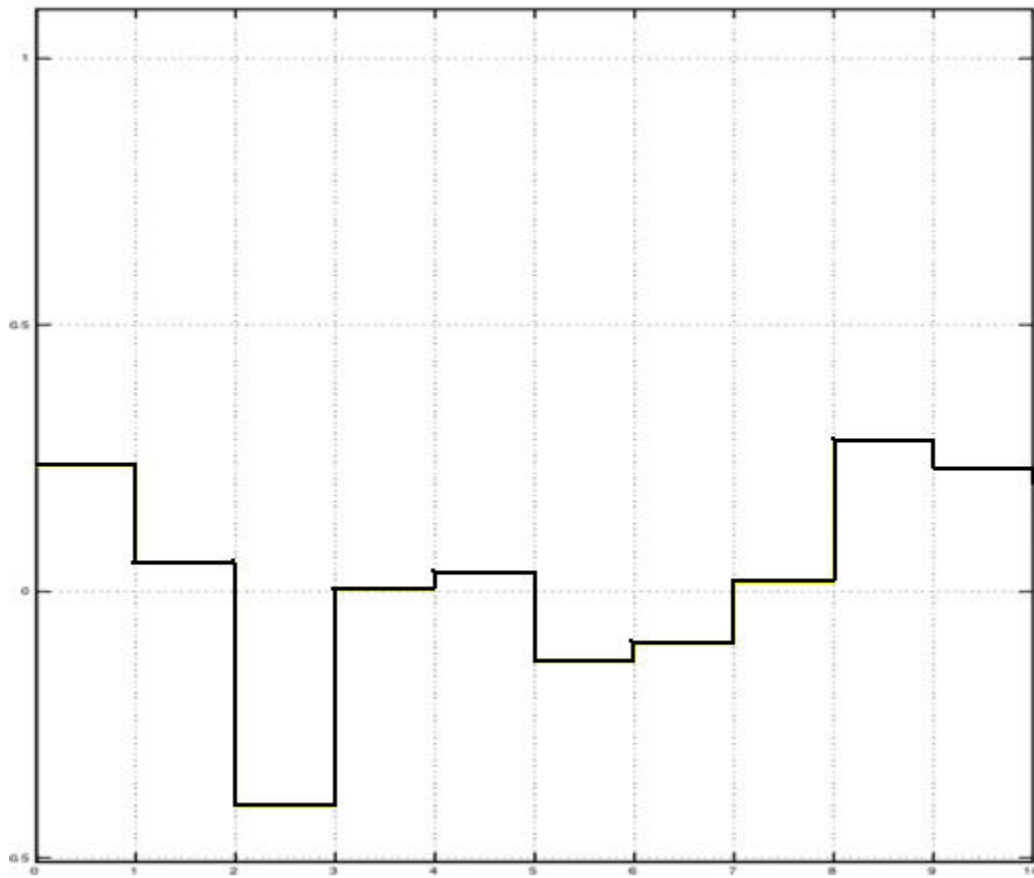

RESULT:

Thus the simulation of the communication link was done using MATLAB and the output verified.

EC6512 – Communication Systems Laboratory

Exp. No.: 12

Date:

Equalization – Zero Forcing & LMS algorithms (simulation)

AIM:

To simulate the zero forcing and LMS algorithms equalizer using MATLAB simulation tool.

APPARATUS REQUIRED:

1. Personal Computer
2. Matlab software R2014a

PROCEDURE:

1. Open Matlab version R2014a.
2. And click the start button.
3. Now select the simulink library browser.
4. Open new file for a new project and fix the tools from the simulink library browser, the connect the all tools and save it.
5. Now press run button for to simulate communication link.
6. Note down the output.

MATLAB CODE FOR ZERO FORCING EQUALIZER:

```
%Project: Zero Forcing Equalizer
%Discription: Zero Forcing Equalizer is a type of linear
%equalizers used to
%combat ISI(inter symbol interference). This codes is a
%demostration of a
%simple implemenation of Zero Forcing Equalizer using
MatLab tools.
```

```
function Xh = ZF(h,r)
    %r --- signal at the receiver
    % h--- impulse response of the channel
    %Computing inverse impulse response
gD=tf(h,1);    %taking impulse response and transforming
              %it to S domain
f=1/gD;       % taking inverse of a transfer %function
[num,den]=tfdata(f,'v');    % extracting numerator and
                          %denominator %coefficients
```

EC6512 – Communication Systems Laboratory

```
%Zero forcing
Xh=filter(num,den,r); % filtering

Xh=Xh(2:end); %this done for technical reasons
End
```

SIMULINK DIAGRAM OF LMS LINEAR EQUALIZER:

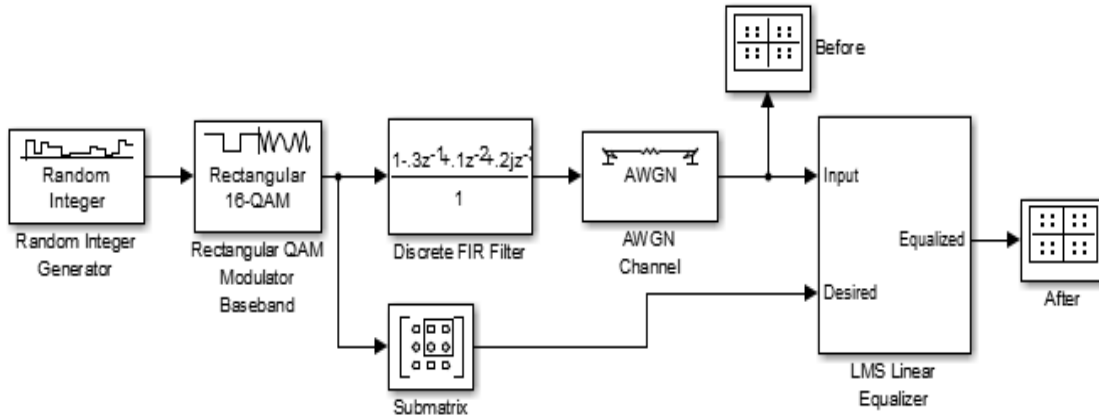

OUTPUT:

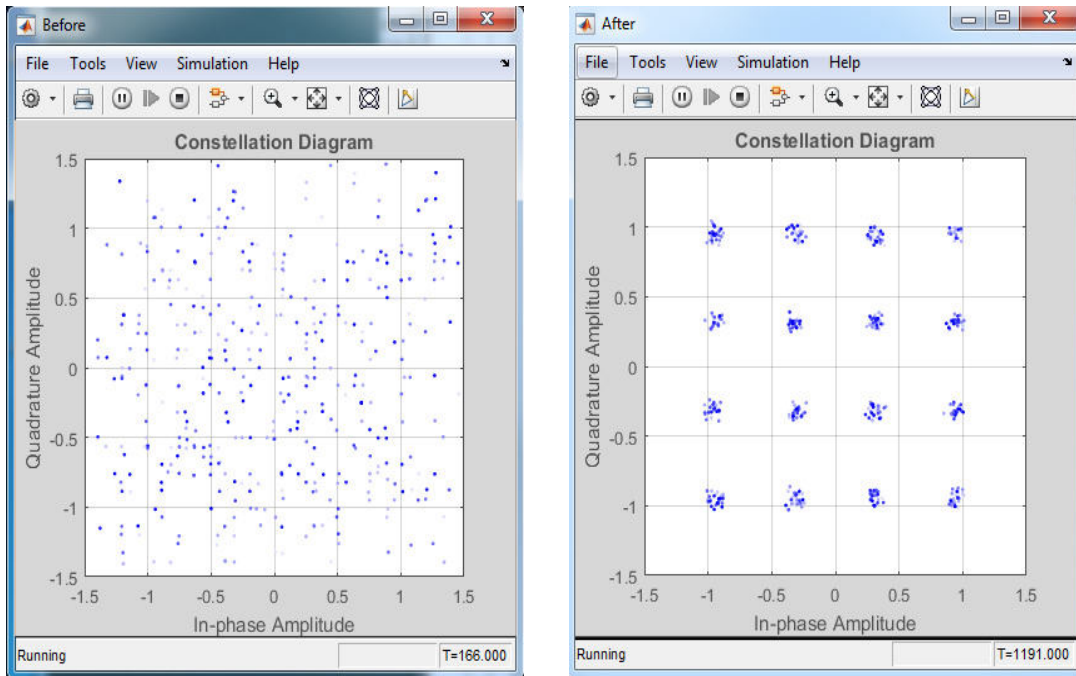

RESULT:

Thus the simulations of zero forcing and LMS algorithms equalizer has been done using MATLAB and the output verified.