



# Varuwan Vadivelan Institute of Technology

Dharmapuri – 636 703

---

## LAB MANUAL

Regulation : 2013

Branch : *B.E.* - ECE

Year & Semester : III Year / V Semester

EC6511-DIGITAL SIGNAL PROCESSING LABORATORY

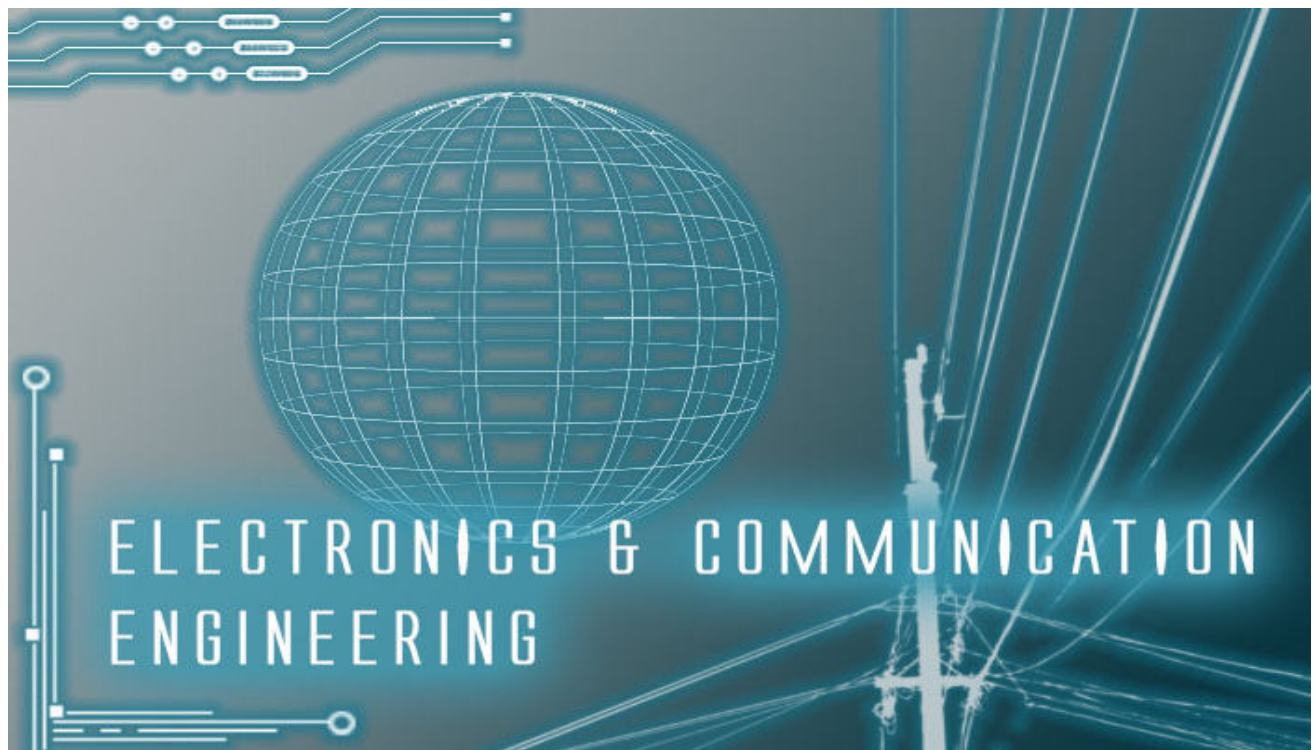

**ANNA UNIVERSITY CHENNAI**

**Regulation 2013**

**EC6511-DIGITAL SIGNAL PROCESSING LABORATORY**

**LIST OF EXPERIMENTS:**

**MATLAB / EQUIVALENT SOFTWARE PACKAGE**

1. Generation of sequences (functional & random) & correlation
2. Linear and Circular Convolutions
3. Spectrum Analysis using DFT
4. FIR filter design
5. IIR filter design
6. Multirate Filters
7. Equalization

**DSP PROCESSOR BASED IMPLEMENTATION**

8. Study of architecture of Digital Signal Processor
9. MAC operation using various addressing modes
10. Linear Convolution
11. Circular Convolution
12. FFT Implementation
13. Waveform generation
14. IIR and FIR Implementation
15. Finite Word Length Effect

**TOTAL: 45 PERIODS**

# INDEX

## LIST OF EXPERIMENTS

S. No	Date	Name of the Experiment	Page no	Marks	Signature
1a		Generation of Continuous Time Signals			
1b		Generation of Discrete Time Signals			
2		Correlation of Sequences			
3		Linear and Circular Convolutions			
4		Spectrum Analysis using DFT			
5a		Design of FIR Filters (rectangular window design)			
5b		Design of FIR Filters (Hanning window design)			
6		Design of IIR Filters			
7		Multirate Filters			
8		Equalization			
9		Study of Architecture of Digital Signal Processor			
10		MAC Operation using Various Addressing Modes			
11		Linear Convolution			
12		Circular Convolution			
13		FFT Implementation			
14		Waveform Generation			
15a		Design of FIR Filters			
15b		Design of IIR Filters			
16		Analysis of Finite Word Length Effect in Fixed Point DSP Systems			

## INTRODUCTION

MATLAB is a software package for high performance numerical computation and visualization provides an interactive environment with hundreds of a built in functions for technical computation, graphics and animation. The MATLAB name stands for Matrix laboratory.

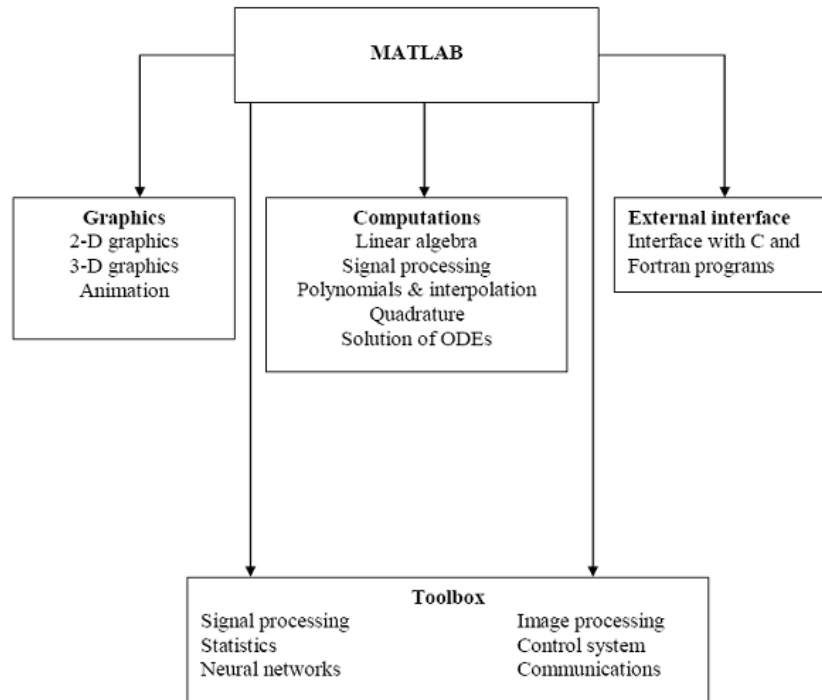

At its core, MATLAB is essentially a set (a “toolbox”) of routines (called “m files” or “mex files”) that sit on your computer and a window that allows you to create new variables with names (e.g. voltage and time) and process those variables with any of those routines (e.g. plot voltage against time, find the largest voltage, etc).

It also allows you to put a list of your processing requests together in a file and save that combined list with a name so that you can run all of those commands in the same order at some later time. Furthermore, it allows you to run such lists of commands such that you pass in data, and/or get data back out (i.e. the list of commands is like a function in most programming languages). Once you save a function, it becomes part of your toolbox. For those with computer programming backgrounds: Note that MATLAB runs as an interpretive language (like the old BASIC). That is, it does not need to be compiled. It simply reads through each line of the function, executes it, and then goes on to the next line.

## DSP Development System

- Testing the software and hardware tools with Code Composer Studio
- Use of the TMS320C6713 DSK
- Programming examples to test the tools

Digital signal processors such as the TMS320C6x (C6x) family of processors are like fast special-purpose microprocessors with a specialized type of architecture and an instruction set appropriate for signal processing. The C6x notation is used to designate a member of Texas Instruments' (TI) TMS320C6000 family of digital signal processors. The architecture of the C6x digital signal processor is very well suited for numerically intensive calculations. Based on a very-long-instruction-word (VLIW) architecture, the C6x is considered to be TI's most powerful processor. Digital signal processors are used for a wide range of applications, from communications and controls to speech and image processing. The general-purpose digital signal processor is dominated by applications in communications (cellular). Applications embedded digital signal processors are dominated by consumer products. They are found in cellular phones, fax/modems, disk drives, radio, printers, hearing aids, MP3 players, high-definition television (HDTV), digital cameras, and so on. These processors have become the products of choice for a number of consumer applications, since they have become very cost-effective. They can handle different tasks, since they can be reprogrammed readily for a different application.

DSP techniques have been very successful because of the development of low-cost software and hardware support. For example, modems and speech recognition can be less expensive using DSP techniques. DSP processors are concerned primarily with real-time signal processing. Real-time processing requires the processing to keep pace with some external event, whereas non-real-time processing has no such timing constraint. The external event to keep pace with is usually the analog input. Whereas analog-based systems with discrete electronic components such as resistors can be more sensitive to temperature changes, DSP-based systems are less affected by environmental conditions.

DSP processors enjoy the advantages of microprocessors. They are easy to use, flexible, and economical. A number of books and articles address the importance of digital signal processors for a number of applications. Various technologies have been used for real-time processing, from fiber optics for very high frequency to DSPs very suitable for the audio-frequency range. Common applications using these processors have been for frequencies from 0 to 96kHz. Speech can be sampled at 8 kHz (the rate at which samples are acquired), which implies that each value sampled is acquired at a rate of  $1/(8 \text{ kHz})$  or 0.125ms. A commonly used sample rate of a compact disk is 44.1 kHz. Analog/digital (A/D)-based boards in the megahertz sampling rate range are currently available.

**Ex. No: 1a**

**Date:**

## **GENERATION OF CONTINUOUS TIME SIGNALS**

### **AIM:**

To generate a functional sequence of a signal (Sine, Cosine, triangular, Square, Saw tooth and sinc ) using MATLAB function.

### **APPARATUS REQUIRED:**

HARDWARE : Personal Computer

SOFTWARE : MATLAB R2014a

### **PROCEDURE:**

1. Start the MATLAB program.
2. Open new M-file
3. Type the program
4. Save in current directory
5. Compile and Run the program
6. If any error occurs in the program correct the error and run it again
7. For the output see command window\ Figure window
8. Stop the program.

### **PROGRAM: (Generation of Continuous Time Signals)**

```
%Program for sine wave
t=0:0.1:10;
y=sin(2*pi*t);
subplot(3,3,1);
plot(t,y,'k');
xlabel('Time');
ylabel('Amplitude');
title('Sine wave');

%Program for cosine wave
t=0:0.1:10;
y=cos(2*pi*t);
subplot(3,3,2);
plot(t,y,'k');
xlabel('Time');
ylabel('Amplitude');
title('Cosine wave');

%Program for square wave
t=0:0.001:10;
y=square(t);
subplot(3,3,3);
```

```
plot(t,y,'k');
xlabel('Time');
ylabel('Amplitude');
title('Square wave');

%Program for sawtooth wave
t=0:0.1:10;
y=sawtooth(t);
subplot(3,3,4);
plot(t,y,'k');
xlabel('Time');
ylabel('Amplitude');
title('Sawtooth wave');

%Program for Triangular wave
t=0:.0001:20;
y=sawtooth(t,.5); % sawtooth with 50% duty cycle
(triangular)
subplot(3,3,5);
plot(t,y);
ylabel('Amplitude');
xlabel('Time Index');
title('Triangular waveform');
%Program for Sinc Pulse
t=-10:.01:10;
y=sinc(t);
axis([-10 10 -2 2]);
subplot(3,3,6);
plot(t,y);
ylabel('Amplitude');
xlabel('Time Index');
title('Sinc Pulse');

% Program for Exponential Growing signal
t=0:.1:8;
a=2;
y=exp(a*t);
subplot(3,3,7);
plot(t,y);
ylabel('Amplitude');
xlabel('Time Index');
title('Exponential growing Signal');

% Program for Exponential Growing signal
t=0:.1:8;
a=2;
y=exp(-a*t);
subplot(3,3,8);
plot(t,y);
ylabel('Amplitude');
xlabel('Time Index');
title('Exponential decaying Signal');
```

**OUTPUT: (Generation of Continuous Time Signals)**

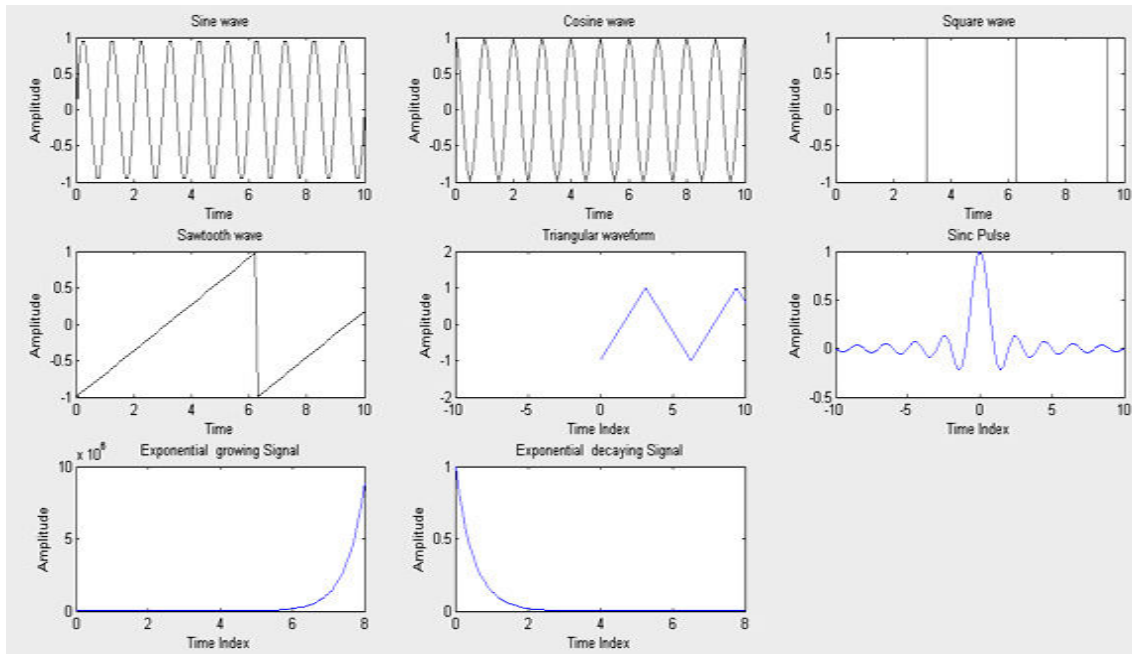

**RESULT:**

Thus the MATLAB programs for functional sequence of a signal (Sine, Cosine, triangular, Square, Saw tooth and sinc ) using MATLAB function written and the results were plotted.

**Ex. No: 1b**

**Date:**

**GENERATION OF DISCRETE TIME SIGNALS**

**AIM:**

To generate a discrete time signal sequence (Unit step, Unit ramp, Sine, Cosine, Exponential, Unit impulse) using MATLAB function.

**APPARATUS REQUIRED:**

HARDWARE : Personal Computer

SOFTWARE : MATLAB R2014a

**PROCEDURE:**

1. Start the MATLAB program.
2. Open new M-file
3. Type the program
4. Save in current directory
5. Compile and Run the program
6. If any error occurs in the program correct the error and run it again
7. For the output see command window\ Figure window
8. Stop the program.

**PROGRAM:** (Generation of Discrete Time Signals)

```
%Program for unit step sequence
    clc;
    N=input('Enter the length of unit step sequence(N)= ');
    n=0:1:N-1;
    y=ones(1,N);
    subplot(3,2,1);
    stem(n,y,'k');
    xlabel('Time')
    ylabel('Amplitude')
    title('Unit step sequence');
%Program for unit ramp sequence
    N1=input('Enter the length of unit ramp sequence(N1)= ');
    n1=0:1:N1-1;
    y1=n1;
    subplot(3,2,2);
    stem(n1,y1,'k');
    xlabel('Time');
    ylabel('Amplitude');
    title('Unit ramp sequence');
%Program for sinusoidal sequence
    N2=input('Enter the length of sinusoidal sequence(N2)=
    ');
    n2=0:0.1:N2-1;
    y2=sin(2*pi*n2);
    subplot(3,2,3);
    stem(n2,y2,'k');
    xlabel('Time');
    ylabel('Amplitude');
    title('Sinusoidal sequence');
%Program for cosine sequence
    N3=input('Enter the length of the cosine sequence(N3)=');
    n3=0:0.1:N3-1;
    y3=cos(2*pi*n3);
    subplot(3,2,4);
    stem(n3,y3,'k');
    xlabel('Time');
    ylabel('Amplitude');
    title('Cosine sequence');
%Program for exponential sequence
    N4=input('Enter the length of the exponential
    sequence(N4)= ');
    n4=0:1:N4-1;
    a=input('Enter the value of the exponential sequence(a)=
    ');
    y4=exp(a*n4);
    subplot(3,2,5);
    stem(n4,y4,'k');
    xlabel('Time');
    ylabel('Amplitude');
    title('Exponential sequence');
%Program for unit impulse
    n=-3:1:3;
    y=[zeros(1,3),ones(1,1),zeros(1,3)];
```

```
subplot(3,2,6);  
stem(n,y,'k');  
xlabel('Time');  
ylabel('Amplitude');  
title('Unit impulse');
```

**OUTPUT:** (Generation of Discrete Time Signals)

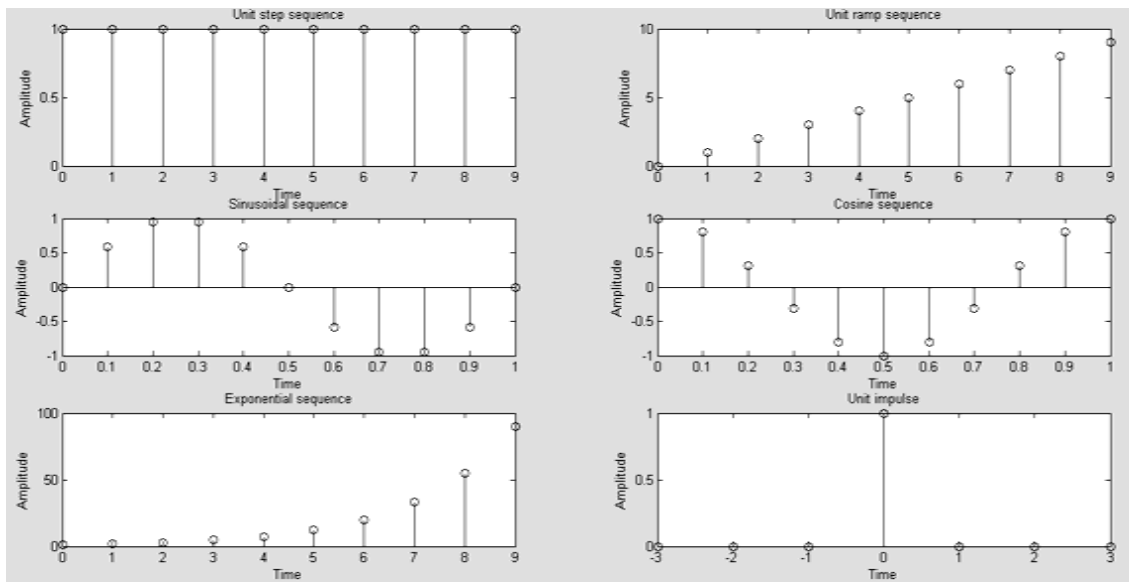

**RESULT:**

Thus the MATLAB programs for discrete time signal sequence (Unit step, Unit ramp, Sine, Cosine, Exponential, Unit impulse) using MATLAB function written and the results were plotted.

**Ex. No: 2**

**Date:**

### **CORRELATION OF SEQUENCES**

**AIM:**

To write MATLAB programs for auto correlation and cross correlation.

**APPARATUS REQUIRED:**

HARDWARE : Personal Computer

SOFTWARE : MATLAB R2014a

**PROCEDURE:**

1. Start the MATLAB program.
2. Open new M-file
3. Type the program
4. Save in current directory
5. Compile and Run the program
6. If any error occurs in the program correct the error and run it again
7. For the output see command window\ Figure window
8. Stop the program.

**PROGRAM:** (Cross-Correlation of the Sequences)

```

clc;
clear all;
close all;
x=input('Enter the sequence 1: ');
h=input('Enter the sequence 2: ');
y=xcorr(x,h);
figure;
subplot(3,1,1);
stem(x);
xlabel('n->');
ylabel('Amplitude->');
title('Input sequence 1');
subplot(3,1,2);
stem(fliplr(y));
stem(h);
xlabel('n->');
ylabel('Amplitude->');
title('Input sequence 2');
subplot(3,1,3);
stem(fliplr(y));
xlabel('n->');
ylabel('Amplitude->');
title('Output sequence');
disp('The resultant is');
fliplr(y);

```

**OUTPUT:** (Cross-Correlation of the Sequences)

Enter the sequence 1: [1 3 5 7]  
 Enter the sequence 2: [2 4 6 8]

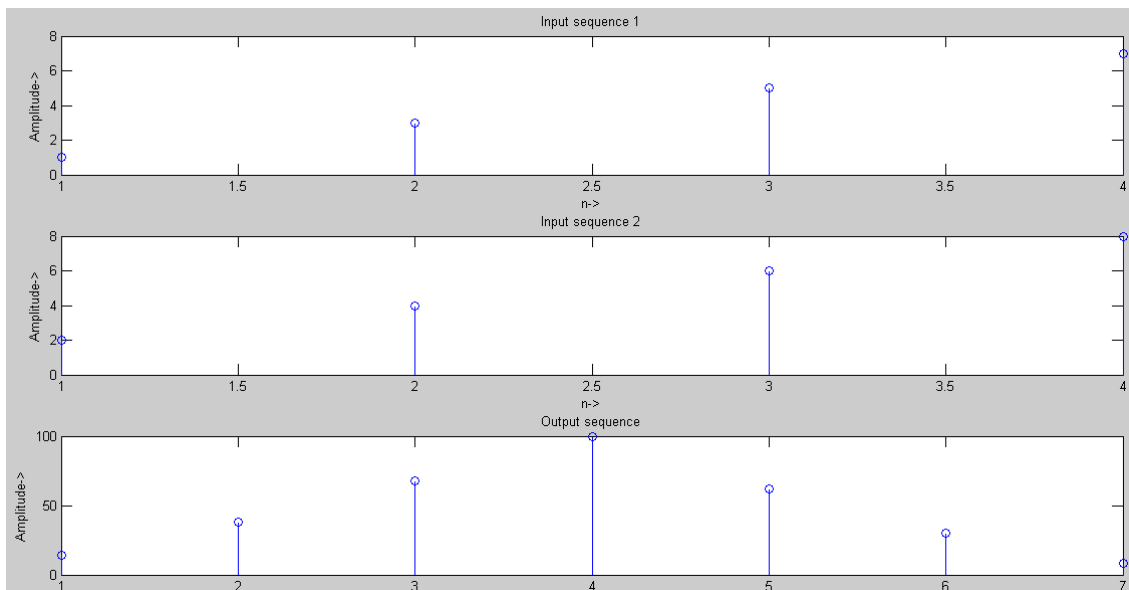

**PROGRAM:** (Auto Correlation Function)

```
clc;
close all;
clear all;
x=input('Enter the sequence 1: ');
y=xcorr(x,x);
figure;
subplot(2,1,1);
stem(x);
ylabel('Amplitude->');
xlabel('n->');
title('Input sequence');
subplot(2,1,2);
stem(fliplr(y));
ylabel('amplitude');
xlabel('n->');
title('Output sequence');
disp('the resultant is ');
fliplr(y);
```

**OUTPUT:** (Auto Correlation Function)

Enter the sequence [1 2 3 4]

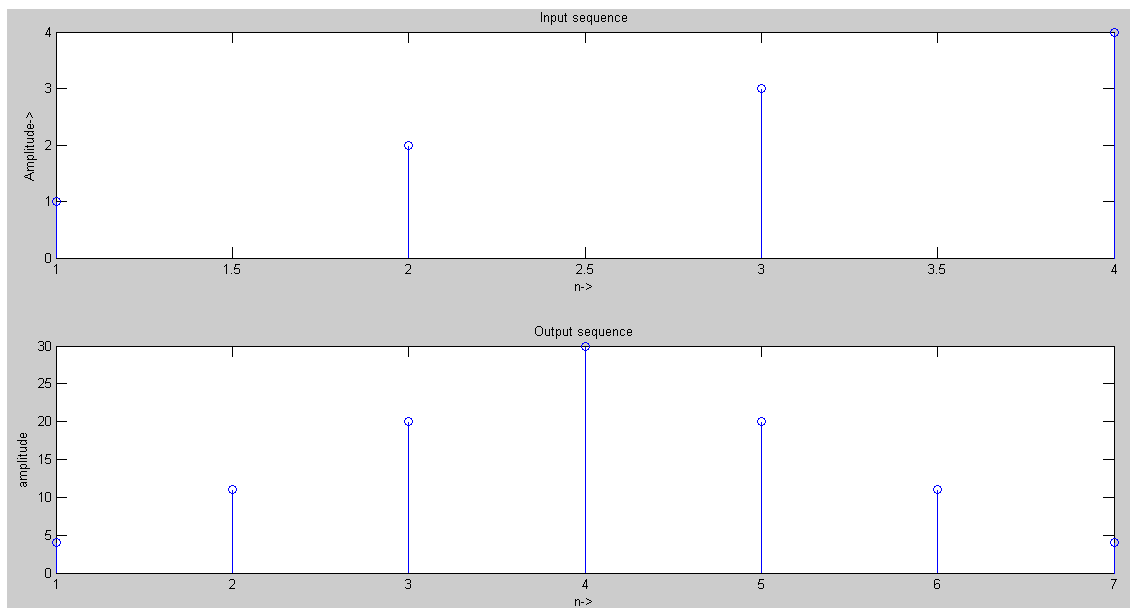

**RESULT:**

Thus the MATLAB programs for auto correlation and cross correlation written and the results were plotted.

**Ex. No: 3**

**Date:**

**LINEAR AND CIRCULAR CONVOLUTIONS**

**AIM:**

To write MATLAB programs to find out the linear convolution and Circular convolution of two sequences.

**APPARATUS REQUIRED:**

HARDWARE : Personal Computer

SOFTWARE : MATLAB R2014a

**PROCEDURE:**

1. Start the MATLAB program.
2. Open new M-file
3. Type the program
4. Save in current directory
5. Compile and Run the program
6. If any error occurs in the program correct the error and run it again
7. For the output see command window\ Figure window
8. Stop the program.

**PROGRAM:** (Linear Convolution)

```
% linear convolution
close all
clear all
x=input('Enter x:  ')
h=input('Enter h:  ')
m=length(x);
n=length(h);
X=[x, zeros(1, n)];
H=[h, zeros(1, m)];
for i=1:n+m-1
    Y(i)=0;
    for j=1:i
        Y(i)=Y(i)+X(j)*H(i-j+1);
    end
end
Y
stem(Y);
ylabel('Y[n]');
xlabel('----->n');
title('Convolution of Two Signals without conv
function');
```

**INPUT:**

```
enter x:  [1 2 3 4 5]
x = 1 2 3 4 5
Enter h:  [1 2 3 1]
h = 1 2 3 1
Y =      1 4 10 17 24 25 19 5
```

**OUTPUT:** (Linear Convolution)

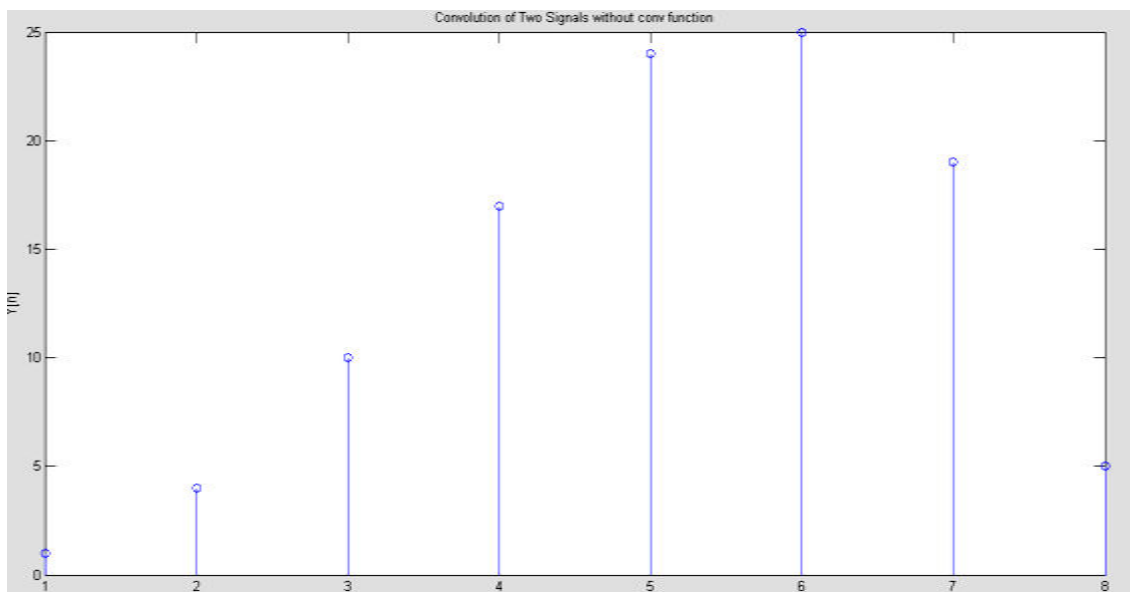

**PROGRAM:** (Circular Convolution)

```

clc; clear;
a = input('enter the sequence x(n) = ');
b = input('enter the sequence h(n) = ');
n1=length(a);
n2=length(b);
N=max(n1,n2);
x = [a zeros(1, (N-n1))];
for i = 1:N
k = i;
for j = 1:n2
H(i, j)=x(k) * b(j);
k = k-1;
if (k == 0)
k = N;
end end end
y=zeros(1,N);
M=H';
for j = 1:N
for i = 1:n2
y(j)=M(i, j)+y(j);
end end
disp('The output sequence is y(n)= ');
disp(y);
stem(y);
title('Circular Convolution');
xlabel('n');
ylabel('y(n)');

```

**OUTPUT:** (Circular Convolution)

```

Enter the sequence x(n) = [1 2 3 4]
Enter the sequence h(n) = [1 2 1 1]
The output sequence is y(n)=      14      11      12      13

```

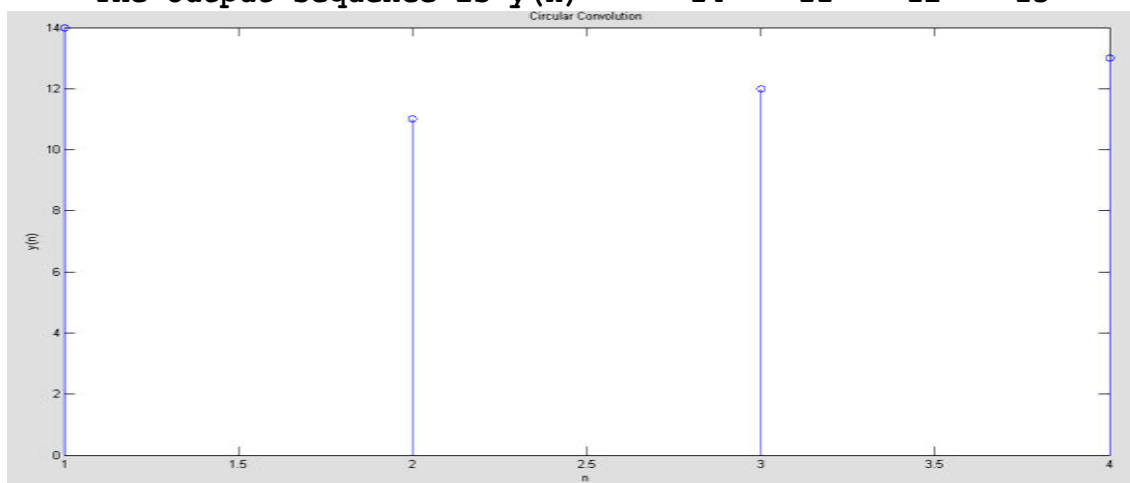

**RESULT:**

Thus the MATLAB programs for linear convolution and circular convolution written and the results were plotted.

**Ex. No: 4**

**Date:**

**SPECTRUM ANALYSIS USING DFT**

**AIM:**

To write MATLAB program for spectrum analyzing signal using DFT.

**APPARATUS REQUIRED:**

HARDWARE : Personal Computer

SOFTWARE : MATLAB R2014a

**PROCEDURE:**

1. Start the MATLAB program.
2. Open new M-file
3. Type the program
4. Save in current directory
5. Compile and Run the program
6. If any error occurs in the program correct the error and run it again
7. For the output see command window\ Figure window
8. Stop the program.

**PROGRAM:** (Spectrum Analysis Using DFT)

```
N=input('type length of DFT= ');
T=input('type sampling period= ');
freq=input('type the sinusoidal freq= ');
k=0:N-1;
f=sin(2*pi*freq*1/T*k);
F=fft(f);
stem(k,abs(F));
grid on;
xlabel('k');
ylabel('X(k)');
```

**INPUT:**

```
type length of DFT=32
type sampling period=64
type the sinusoidal freq=11
```

**OUTPUT:** (Spectrum Analysis Using DFT)

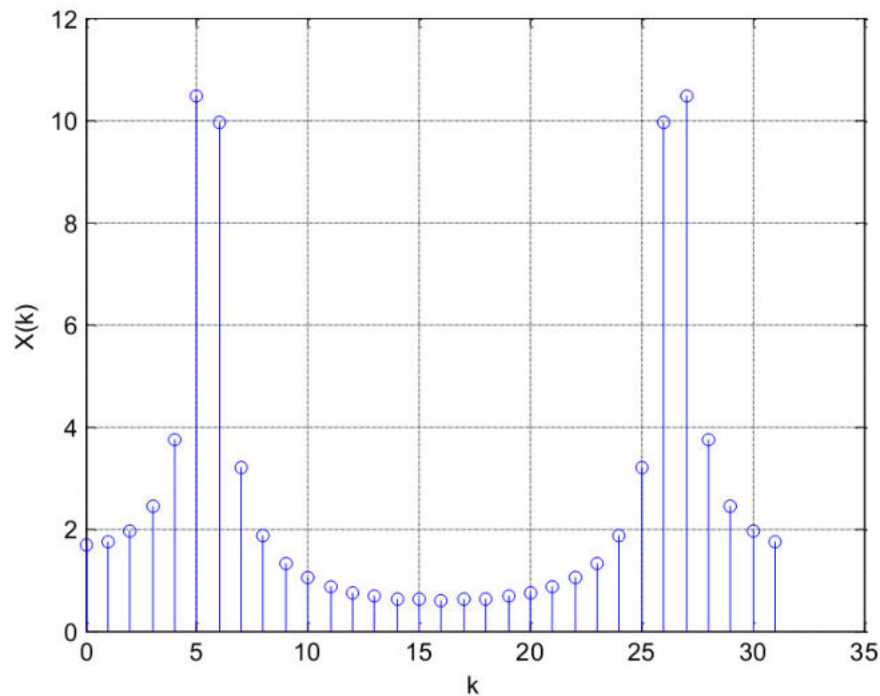

**RESULT:**

Thus the Spectrum Analysis of the signal using DFT is obtained using MATLAB.

**Ex. No: 5a**

**Date:**

**DESIGN OF FIR FILTERS  
(RECTANGULAR WINDOW DESIGN)**

**AIM:**

To write a program to design the FIR low pass, High pass, Band pass and Band stop filters using RECTANGULAR window and find out the response of the filter by using MATLAB.

**APPARATUS REQUIRED:**

HARDWARE : Personal Computer

SOFTWARE : MATLAB R2014a

**PROCEDURE:**

1. Start the MATLAB program.
2. Open new M-file
3. Type the program
4. Save in current directory
5. Compile and Run the program
6. If any error occurs in the program correct the error and run it again
7. For the output see command window\ Figure window
8. Stop the program.

**PROGRAM: (Rectangular Window)**

```

clear all;
rp=input('Enter the PB ripple rp =');
rs=input('Enter the SB ripple rs =');
fp=input('Enter the PB ripple fp =');
fs=input('Enter the SB ripple fs =');
f=input('Enter the sampling frequency f =');
wp=2*fp/f;
ws=2*fs/f;
num=-20*log10(sqrt(rp*rs))-13;
den=14.6*(fs-fp)/f;
n=ceil(num/den);
n1=n+1;
if(rem(n,2)~=0)
    n=n1;
    n=n-1;
end;
y=boxcar(n1);
%LPF
b=fir1(n,wp,y);
[h,o]=freqz(b,1,256);
m=20*log10(abs(h));
subplot(2,2,1);
plot(o/pi,m);
xlabel('Normalized frequency----->');
ylabel('Gain in db-----');
title('MAGNITUDE RESPONSE OF LPF');

%HPF
b=fir1(n,wp,'high',y);
[h,o]=freqz(b,1,256);
m=20*log10(abs(h));
subplot(2,2,2);
plot(o/pi,m);
xlabel('Normalized frequency----->');
ylabel('Gain in db-----');
title('MAGNITUDE RESPONSE OF HPF');

%BPF
wn=[wp ws];
b=fir1(n,wn,y);
[h,o]=freqz(b,1,256);
m=20*log10(abs(h));
subplot(2,2,3);
plot(o/pi,m);
xlabel('Normalized frequency----->');
ylabel('Gain in db-----');
title('MAGNITUDE RESPONSE OF BPF');

%BSF
b=fir1(n,wn,'stop',y);
[h,o]=freqz(b,1,256);
m=20*log10(abs(h));
subplot(2,2,4);
plot(o/pi,m);

```

```
xlabel('Normalized frequency----->');  
ylabel('Gain in db-----');  
title('MAGNITUDE RESPONSE OF BSF');
```

**OUTPUT: (Rectangular Window)**

Enter the PB ripple  $r_p = .03$   
Enter the SB ripple  $r_s = .05$   
Enter the PB ripple  $f_p = 2000$   
Enter the SB ripple  $f_s = 3000$   
Enter the sampling frequency  $f = 9000$

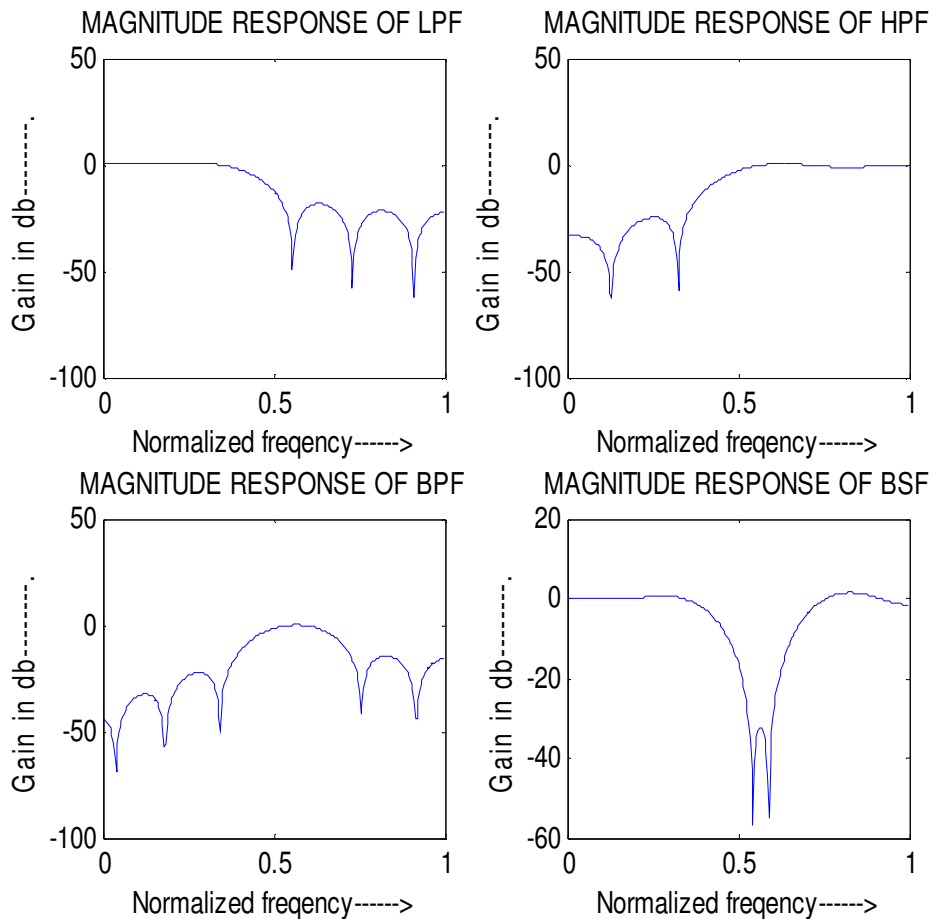

**RESULT:**

Thus the program to design FIR low pass, high pass, band pass and band stop Filters using RECTANGULAR Window was written and response of the filter using MATLAB was executed.

**Ex. No: 5b**

**Date:**

**DESIGN OF FIR FILTERS  
(HANNING WINDOW DESIGN)**

**AIM:**

To write a program to design the FIR low pass, High pass, Band pass and Band stop filters using HANNING window and find out the response of the filter by using MATLAB.

**APPARATUS REQUIRED:**

HARDWARE : Personal Computer

SOFTWARE : MATLAB R2014a

**PROCEDURE:**

1. Start the MATLAB program.
2. Open new M-file
3. Type the program
4. Save in current directory
5. Compile and Run the program
6. If any error occurs in the program correct the error and run it again
7. For the output see command window\ Figure window
8. Stop the program.

**PROGRAM: (Hanning Window)**

```

clear all;
rp=input('Enter the PB ripple rp =');
rs=input('Enter the SB ripple rs =');
fp=input('Enter the PB ripple fp =');
fs=input('Enter the SB ripple fs =');
f=input('Enter the sampling frequency f =');
wp=2*fp/f;
ws=2*fs/f;
num=-20*log10(sqrt(rp*rs))-13;
den=14.6*(fs-fp)/f;
n=ceil(num/den);
n1=n+1;
if(rem(n,2)~=0)
    n=n1;
    n=n-1;
end;
y=hanning(n1);
%LPF
b=fir1(n,wp,y);
[h,0]=freqz(b,1,256);
m=20*log10(abs(h));
subplot(2,2,1);
plot(0/pi,m);
xlabel('Normalized frequency----->');
ylabel('Gain in db-----');
title('MAGNITUDE RESPONSE OF LPF');

%HPF
b=fir1(n,wp,'high',y);
[h,0]=freqz(b,1,256);
m=20*log10(abs(h));
subplot(2,2,2);
plot(0/pi,m);
xlabel('Normalized frequency----->');
ylabel('Gain in db-----');
title('MAGNITUDE RESPONSE OF HPF');

%BPF
wn=[wp ws];
b=fir1(n,wn,y);
[h,0]=freqz(b,1,256);
m=20*log10(abs(h));
subplot(2,2,3);
plot(0/pi,m);
xlabel('Normalized frequency----->');
ylabel('Gain in db-----');
title('MAGNITUDE RESPONSE OF BPF');

%BSF
b=fir1(n,wn,'stop',y);
[h,0]=freqz(b,1,256);
m=20*log10(abs(h));
subplot(2,2,4);
plot(0/pi,m);

```

```
xlabel('Normalized frequency----->');  
ylabel('Gain in db-----');  
title('MAGNITUDE RESPONSE OF BSF');
```

**OUTPUT: (Hanning Window)**

```
Enter the PB ripple rp =.03  
Enter the SB ripple rs =.02  
Enter the PB ripple fp =1500  
Enter the SB ripple fs =2000  
Enter the sampling frequency f =9000
```

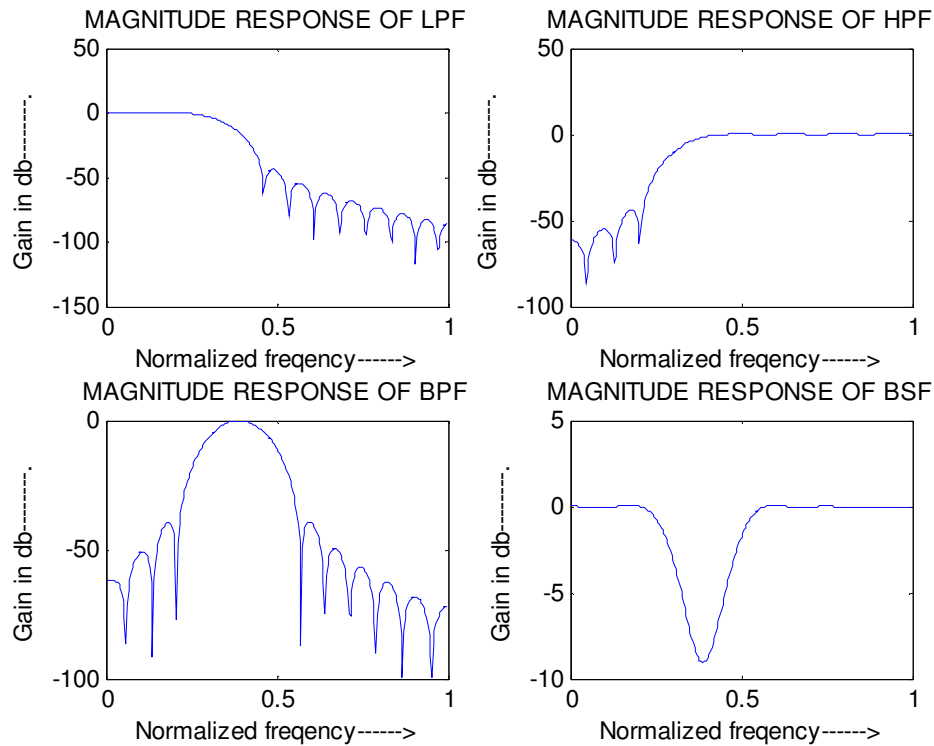

**RESULT:**

Thus the program to design FIR low pass, high pass, band pass and band stop Filters using **HANNING** Window was written and response of the filter using **MATLAB** was executed.

**Ex. No: 6**

**Date:**

**DESIGN OF IIR FILTERS**

**AIM:**

To write a program to design the IIR Filter using Impulse Invariant Transformation method and find out the Magnitude response and Pole Zero Plot by using MATLAB.

**APPARATUS REQUIRED:**

HARDWARE : Personal Computer

SOFTWARE : MATLAB R2014a

**PROCEDURE:**

1. Start the MATLAB program.
2. Open new M-file
3. Type the program
4. Save in current directory
5. Compile and Run the program
6. If any error occurs in the program correct the error and run it again
7. For the output see command window\ Figure window
8. Stop the program.

**PROGRAM:** (IIR Butterworth Filter using Impulse Method)

```

N=input('ENTER THE FILTER ORDER N = ');
fs=input('ENTER THE SAMPLING FREQUENCY fs = ');
fc=input('ENTER THE CUT-OFF FREQUENCY fc = ');
wc=2*pi*fc;
[na,da]=butter(N,wc,'s');
[n,d]=impinvar(na,da,fs);
[h,f]=freqz(n,d,512,fs);
gain=20*log10(abs(h));
subplot(2,1,1);
plot(f,gain);
xlabel('Frequency---->');
ylabel('Magnitude---->');
title('AMPLITUDE RESPONSSE');
subplot(2,1,2);
zplane(n,d);
z=roots(n); p=roots(d);
xlabel('Real part---->');
ylabel('Imaginary part---->');
title('POLE-ZERO PLOT');

```

**OUTPUT:** (IIR Butterworth Filter using Impulse Method)

```

ENTER THE FILTER ORDER N = 2
ENTER THE SAMPLING FREQUENCY fs = 1280
ENTER THE CUT-OFF FREQUENCY fc = 150

```

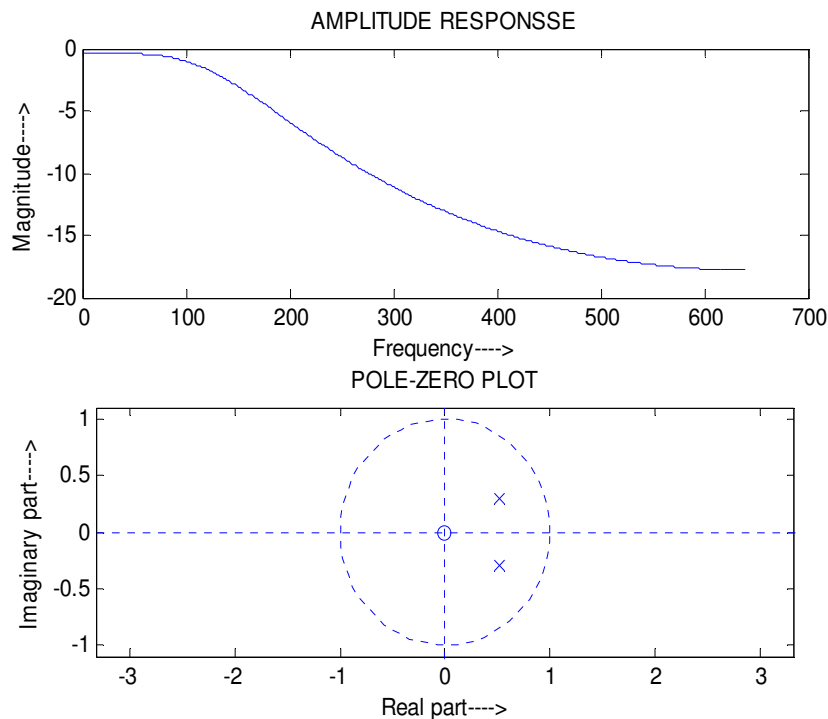

**PROGRAM: (IIR Butterworth Using Bilinear Transformation)**

```
wp=input('ENTER THE PASSBAND EDGE FREQUENCIES wp= ');
ws=input('ENTER THE STOPBAND EDGE FREQUENCIES ws= ');
rp=input('ENTER THE PASSBAND RIPPLE rp= ');
rs=input('ENTER THE STOPBAND RIPPLE rs= ');
fs=input('ENTER THE SAMPLING FREQUENCY fs= ');
wpn=wp/(fs/2);
wsn=ws/(fs/2);
[N,fc]=buttord(wpn,wsn,rp,rs);
disp('ORDER OF THE FILTER');
disp(N);
[n,d]=butter(N,wpn);
[h,f]=freqz(n,d,512,fs);
gain=20*log10(abs(h));
an=angle(h);
subplot(2,1,1);
plot(f,gain);
xlabel('FREQUENCY---->');
ylabel('MAGNITUDE');
title('AMPLITUDE RESPONSE');
subplot(2,1,2);
zplane(n,d);
z=roots(n);
p=roots(d);
xlabel('RREAL PART---->');
ylabel('IMAGINARY PART');
title('POLE-ZERO PLOT');
```

**INPUT: (IIR Butterworth Using Bilinear Transformation)**

```
Enter the passband edge frequencies wp= [200 300]
Enter the stopband edge frequencies ws= [50 450]
Enter the passband ripple rp= 3
Enter the stopband ripple rs= 20
Enter the sampling frequency fs= 1000
Order of the filter      2
```

**OUTPUT: (IIR Butterworth Using Bilinear Transformation)**

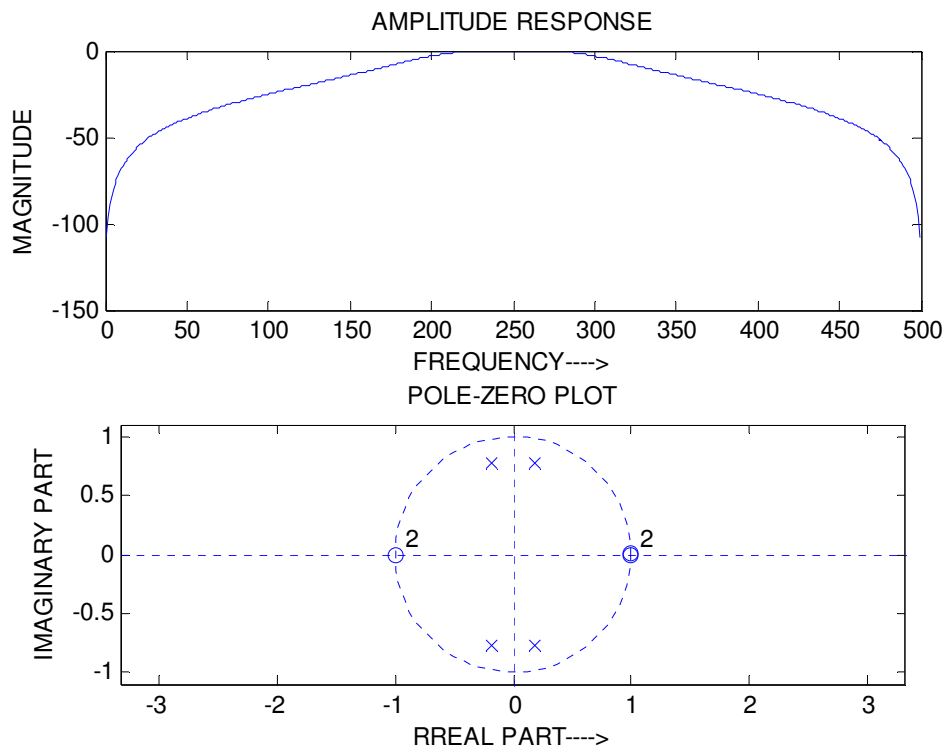

**PROGRAM: (Chebyshev Type 1 Band pass Filter)**

```

clear all;
alphap=2; %pass band attenuation in dB
alphas=20; %stop band attenuation in dB
wp=[.2*pi, .4*pi];
ws=[.1*pi, .5*pi];
%To find cutoff frequency and order of the filter
[n,wn]=buttord(wp/pi,ws/pi,alphap,alphas);
%system function of the filter
[b,a]=cheby1(n,alphap,wn);
w=0:.01:pi;
[h,ph]=freqz(b,a,w);
m=20*log10(abs(h));
an=angle(h);
subplot(2,1,1);
plot(ph/pi,m);
grid;
ylabel('Gain in dB..');
xlabel('Normalised frequency..');
subplot(2,1,2);
plot(ph/pi,an);
grid;
ylabel('Phase in radians..');
xlabel('Normalised frequency..');

```

**OUTPUT:** (Chebyshev Type 1 Band pass Filter)

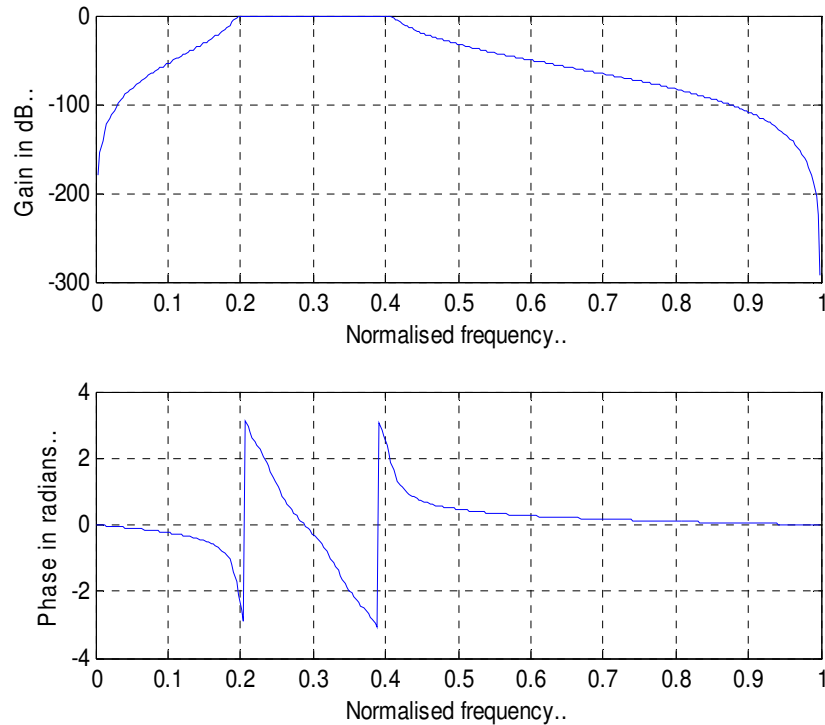

**PROGRAM:** (Chebyshev II Band Reject Filter)

```
clear all;
alphap=2; %pass band attenuation in dB
alphas=20; %stop band attenuation in dB
ws=[.2*pi, .4*pi];
wp=[.1*pi, .5*pi];
%To find cutoff frequency and order of the filter
[n,wn]=cheb2ord(wp/pi,ws/pi,alphap,alphas);
%system function of the filter
[b,a]=cheby2(n,alphas,wn,'stop');
w=0:.01:pi;
[h,ph]=freqz(b,a,w);
m=20*log10(abs(h));
an=angle(h);
subplot(2,1,1);
plot(ph/pi,m);
grid;
ylabel('Gain in dB..');
xlabel('Normalised frequency..');
subplot(2,1,2);
plot(ph/pi,an);
grid;
ylabel('Phase in radians..');
xlabel('Normalised frequency..');
```

**OUTPUT:** (Chebyshev II Band Reject Filter)

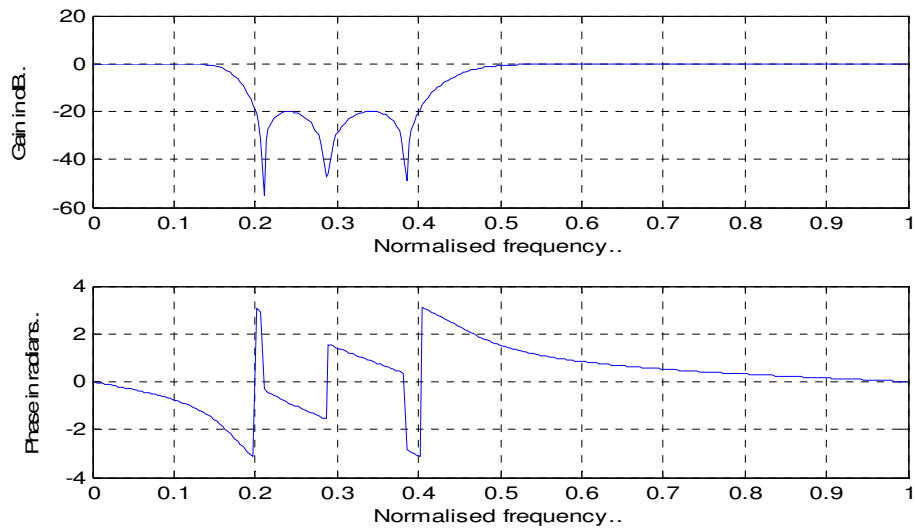

**RESULT:**

Thus the program to design IIR BUTTERWORTH Low Pass Filter using Impulse Invariant Transformation method and find out the Magnitude response and Pole Zero Plot by using MATLAB was executed.

**Ex. No: 7**

**Date:**

### **MULTIRATE FILTERS**

#### **AIM:**

To design linear-phase FIR  $L^{\text{th}}$ -band filters of the length  $N = 31$ , with  $L = 3$  and with the roll-off factors:  $\rho = 0.2, 0.4, \text{ and } 0.6$ . Plot the impulse responses and the magnitude responses for all designs.

#### **APPARATUS REQUIRED:**

HARDWARE : Personal Computer

SOFTWARE : MATLAB R2014a

#### **PROCEDURE:**

1. Start the MATLAB program.
2. Open new M-file
3. Type the program
4. Save in current directory
5. Compile and Run the program
6. If any error occurs in the program correct the error and run it again
7. For the output see command window\ Figure window
8. Stop the program.

**PROGRAM:** (Multirate Filters)

```

close all, clear all
N =31; % Filter length
Nord = N-1; % Filter order
L = 3;
ro1 = 0.2; % Roll-off
factor
h1 = firnyquist(Nord,L,ro1); % Filter design
ro2 = 0.4; % Roll-off
factor
h2 = firnyquist(Nord,L,ro2); % Filter design
ro3 = 0.6; % Roll-off
factor
h3 = firnyquist(Nord,L,ro3); % filter design
figure (1)
subplot (3,1,1)
stem(0:N-1,h1, 'b')
axis([0,30,-0.2,0.5])
ylabel('h_1[n]')
title('Figure 1')
legend('h1')
subplot (3,1,2)
stem(0:N-1,h2, 'k')
axis([0,30,-0.2,0.5])
ylabel('h_2[n]')
legend('h2')
subplot (3,1,3)
stem(0:N-1,h3, 'r')
axis([0,30,-0.2,0.5])
xlabel('n')
ylabel('h_3[n]')
legend('h3')
% Computing frequency responses
[H1,f] = freqz(h1,1,256,2);
[H2,f] = freqz(h2,1,256,2);
[H3,f] = freqz(h3,1,256,2);
figure (2)
plot(f,abs(H1), 'b', f,abs(H2), 'k', f,abs(H3), 'r'), grid
title ('Figure 2')
axis([0,1,0,1.1])
xlabel ('\omega/\pi')
ylabel ('Magnitude')
legend(' |H_1(e^j\omega)| ', '|H_2(e^j\omega)| ', '|H_3(e^j\omega)| ')

```

**OUTPUT: (Multirate Filters)**

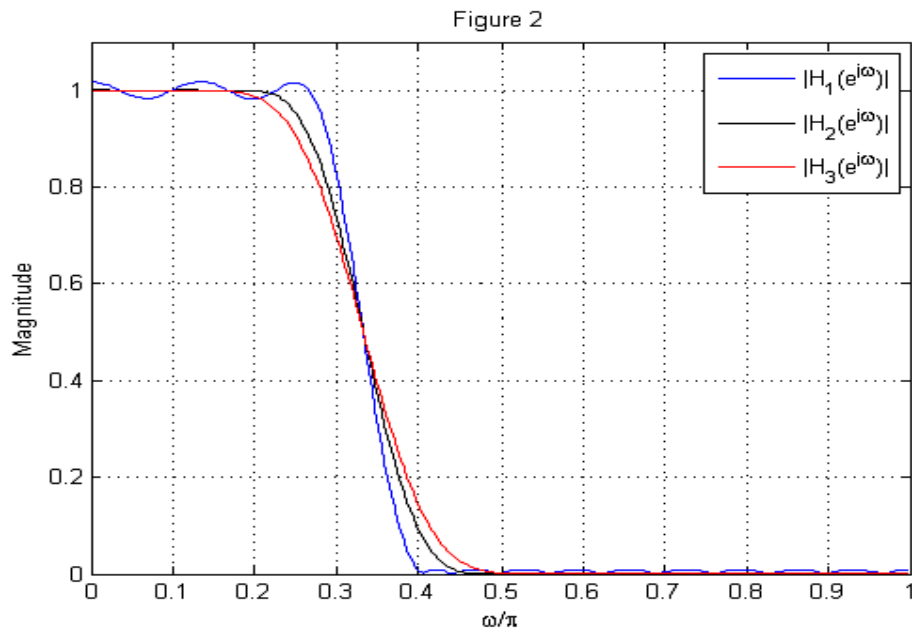
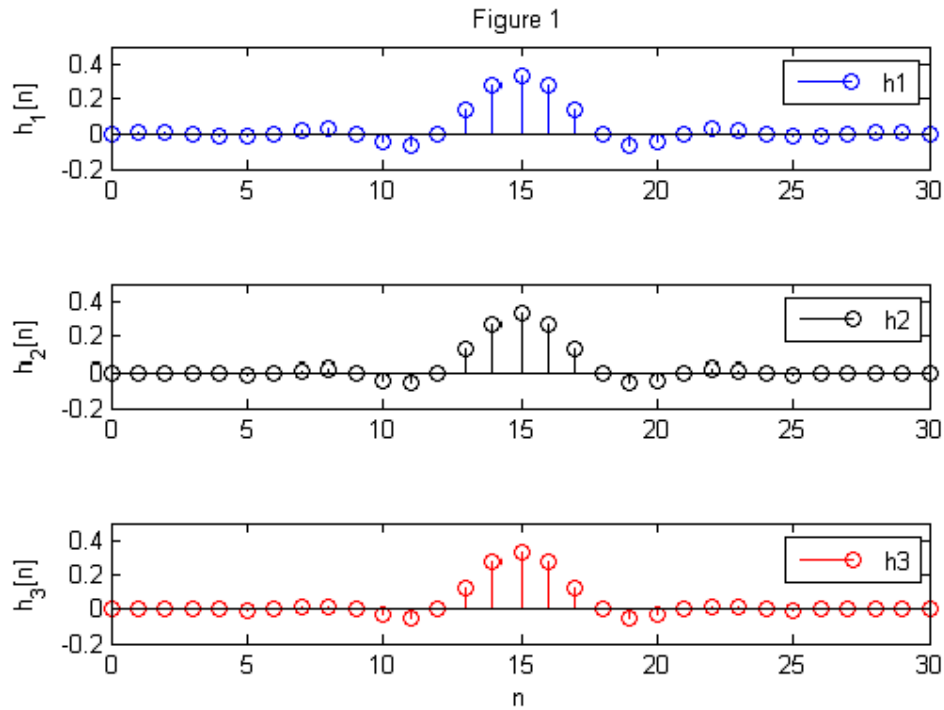

**RESULT:**

Thus the linear phase  $L^{\text{th}}$  band filter is designed and the magnitude response of the filter is obtained using MATLAB.

**Ex. No: 8**

**Date:**

## **EQUALIZATION**

### **AIM:**

To write MATLAB programs for equalization.

### **APPARATUS REQUIRED:**

HARDWARE : Personal Computer

SOFTWARE : MATLAB R2014a

### **PROCEDURE:**

1. Start the MATLAB program.
2. Open new M-file
3. Type the program
4. Save in current directory
5. Compile and Run the program
6. If any error occurs in the program correct the error and run it again
7. For the output see command window\ Figure window
8. Stop the program.

**PROGRAM:** (Equalization)

```

clc;clear all;
close all;
M=3000;
T=2000;
dB=25;
L=20;
ChL=5;
EqD=round((L+ChL)/2);
Ch=randn(1,ChL+1)+sqrt(-1)*randn(1,ChL+1);
Ch=Ch/norm(Ch);
TxS=round(rand(1,M))*2-1;
TxS=TxS+sqrt(-1)*(round(rand(1,M))*2-1);
x=filter(Ch,1,TxS);
n=randn(1,M);
n=n/norm(n)*10^(-dB/20)*norm(x);
x=x+n; K=M-L;
X=zeros(L+1,K);
for i=1:K
X(:,i)=x(i+L:-1:i)';
end
e=zeros(1,T-10);
c=zeros(L+1,1);
mu=0.001;
for i=1:T-10
e(i)=TxS(i+10+L-EqD)-c'*X(:,i+10);
c=c+mu*conj(e(i))*X(:,i+10);
end
sb=c'*X;
sb1=sb/norm(c);
sb1=sign(real(sb1))+sqrt(-1)*sign(imag(sb1));
start=7;
sb2=sb1-TxS(start+1:start+length(sb1));
SER=length(find(sb2~=0))/length(sb2);
disp(SER);
subplot(2,2,1),
plot(TxS,'*');
grid,title('Input symbols'); xlabel('real
part'),ylabel('imaginary part')
axis([-2 2 -2 2])
subplot(2,2,2),
plot(x,'o');
grid, title('Received samples'); xlabel('real part'),
ylabel('imaginary part')
subplot(2,2,3),
plot(sb,'o');
grid, title('Equalized symbols'), xlabel('real part'),
ylabel('imaginary part')
subplot(2,2,4),
plot(abs(e));
grid, title('Convergence'), xlabel('n'),
ylabel('error signal')

```

**OUTPUT: (Equalization)**

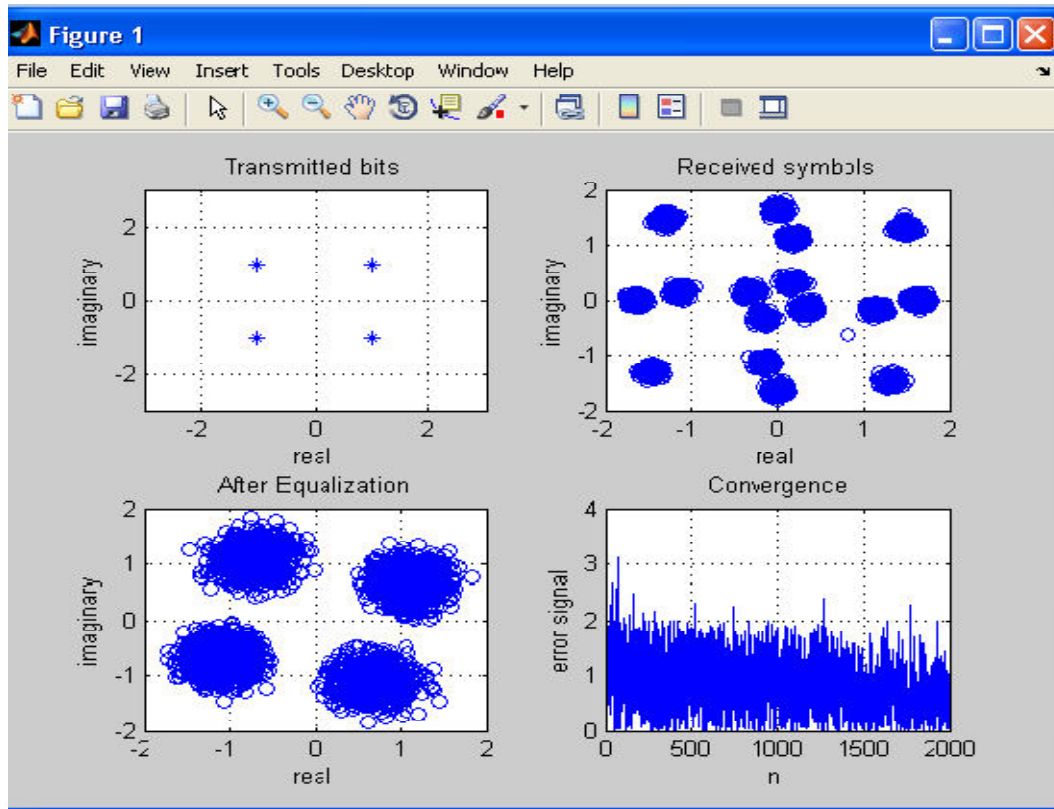

**RESULT:**

Thus the equalization program was designed and developed.

# **DSP PROCESSOR EXPERIMENTS**

## PROCEDURE TO WORK ON CODE COMPOSER STUDIO

### 1. To create a New Project

Project → New (SUM.pjt)

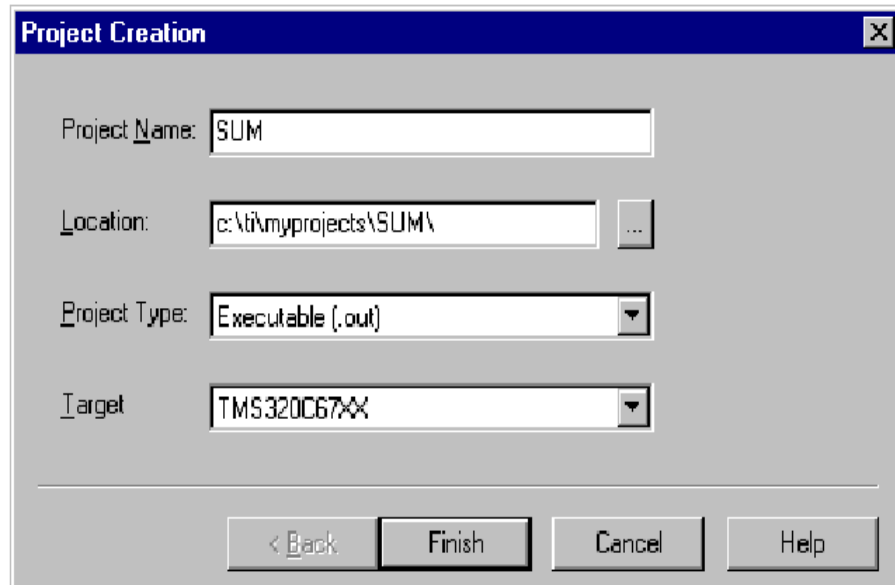

### 2. To Create a Source file

File → New

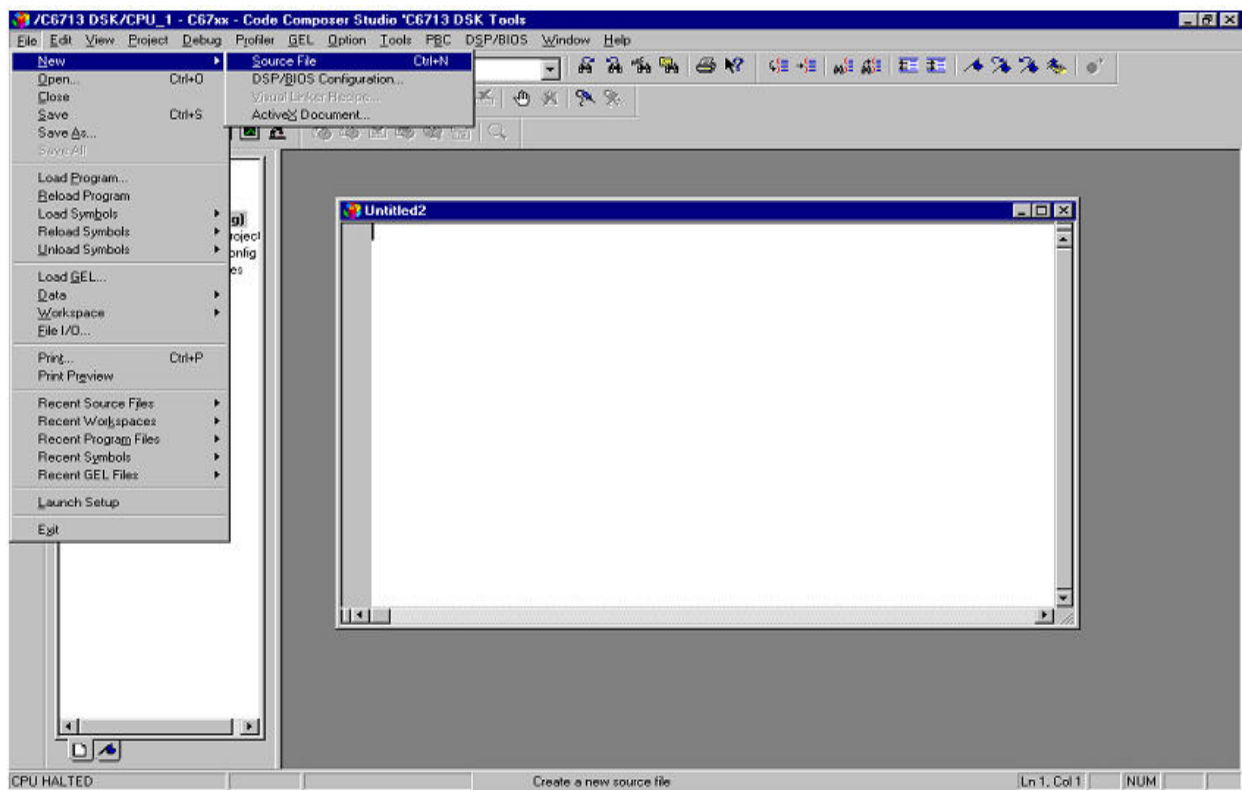

Type the code (Save & give a name to file, Eg: sum.c).

### 3. To Add Source files to Project

Project → Add files to Project → sum.c

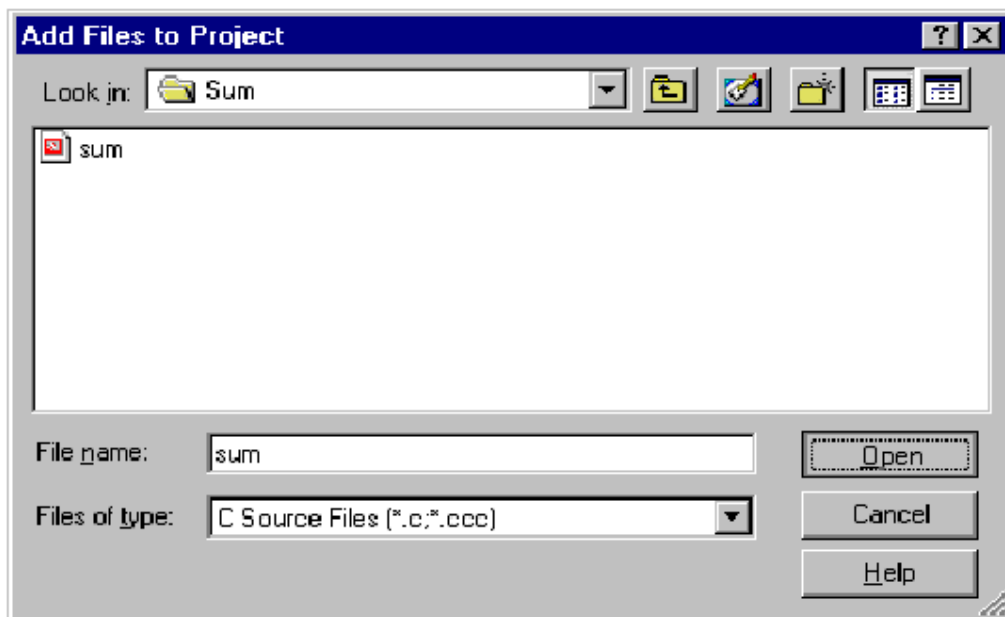
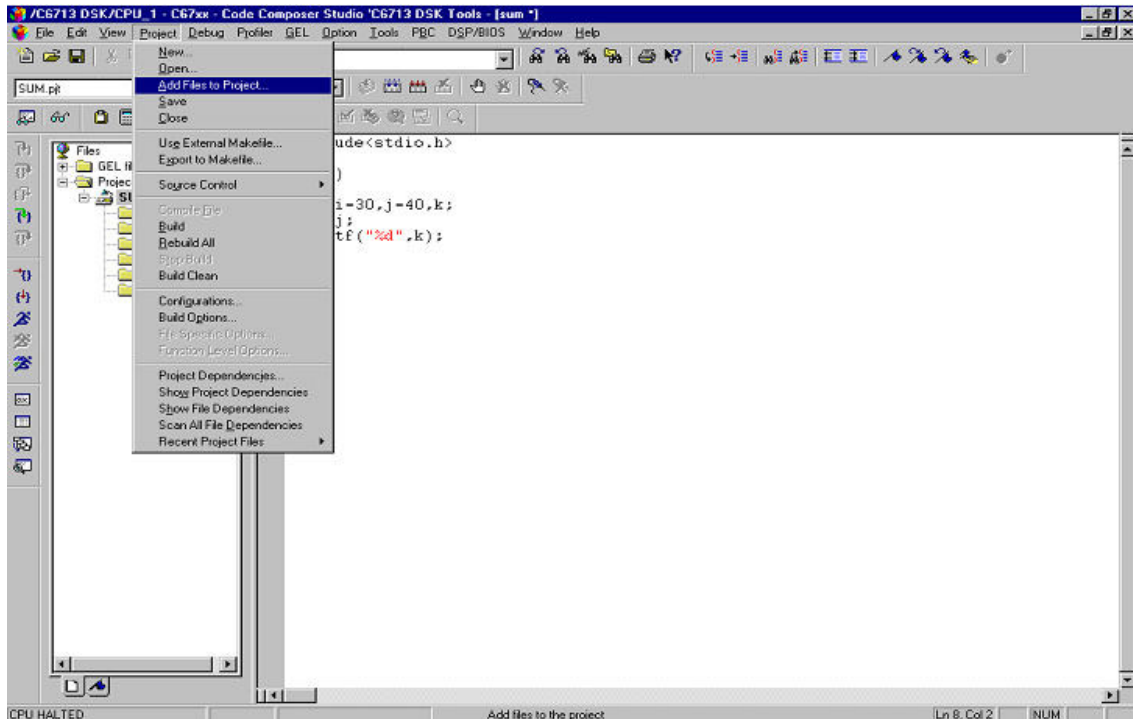

**4. To Add rts6700.lib file & hello.cmd:**

Project → Add files to Project → rts6700.lib

Path: c:\CCStudio\c6000\cgtools\lib\rts6700.lib

Note: Select Object & Library in (\*.o;\*.l) in Type of files

Project → Add files to Project → hello.cmd

Path: c:\ti\tutorial\dsk6713\hello1\hello.cmd

Note: Select Linker Command file (\*.cmd) in Type of files

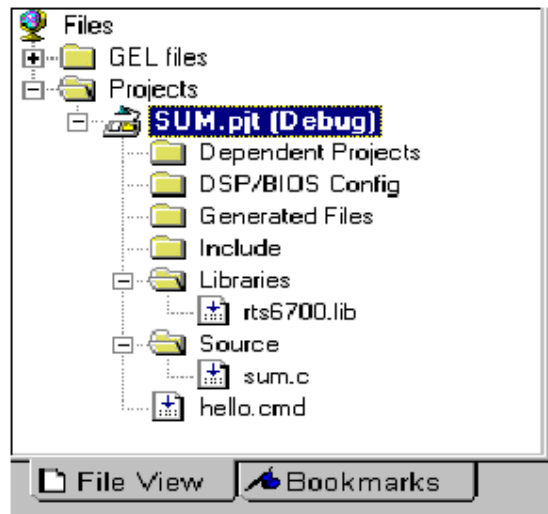

**5. To Compile:**

Project → Compile File

**6. To build or Link:**

Project → build,

Which will create the final executable (.out) file.(Eg. sum.out).

**7. Procedure to Load and Run program:**

Load program to DSK:

File →Load program →sum. Out

**8. To execute project:**

Debug →Run.

**Ex. No: 9**

**Date:**

## **STUDY OF ARCHITECTURE OF DIGITAL SIGNAL PROCESSOR**

### **AIM:**

To study the Architecture of TMS320VC67XX DSP processor.

### **INTRODUCTION**

The hardware experiments in the DSP lab are carried out on the Texas Instruments TMS320C6713 DSP Starter Kit (DSK), based on the TMS320C6713 floating point DSP running at 225MHz. The basic clock cycle instruction time is  $1/(225 \text{ MHz}) = 4.44$  nanoseconds. During each clock cycle, up to eight instructions can be carried out in parallel, achieving up to  $8 \times 225 = 1800$  million instructions per second (MIPS). The DSK board includes a 16MB SDRAM memory and a 512KB Flash ROM. It has an on-board 16-bit audio stereo codec (the Texas Instruments AIC23B) that serves both as an A/D and a D/A converter. There are four 3.5 mm audio jacks for microphone and stereo line input, and speaker and headphone outputs. The AIC23 codec can be programmed to sample audio inputs at the following sampling rates:  $f_s = 8, 16, 24, 32, 44.1, 48, 96$  kHz

The ADC part of the codec is implemented as a multi-bit third-order noise-shaping delta-sigma converter) that allows a variety of oversampling ratios that can realize the above choices of  $f_s$ . The corresponding oversampling decimation filters act as anti-aliasing pre-filters that limit the spectrum of the input analog signals effectively to the Nyquist interval  $[-f_s/2, f_s/2]$ . The DAC part is similarly implemented as a multi-bit second-order noise-shaping delta-sigma converter whose oversampling interpolation filters act as almost ideal reconstruction filters with the Nyquist interval as their pass band.

The DSK also has four user-programmable DIP switches and four LEDs that can be used to control and monitor programs running on the DSP. All features of the DSK are managed by the Code Composer Studio (CCS). The CCS is a complete integrated development environment (IDE) that includes an optimizing C/C++ compiler, assembler, linker, debugger, and program loader. The CCS communicates with the DSK via a USB connection to a PC. In addition to facilitating all programming aspects of the C6713 DSP, the CCS can also read signals stored on the DSP's memory, or the SDRAM, and plot them in the time or frequency domains. The following block diagram depicts the overall operations involved in all of the hardware experiments in the DSP lab. Processing is interrupt-driven at the sampling rate  $f_s$ , as explained below.

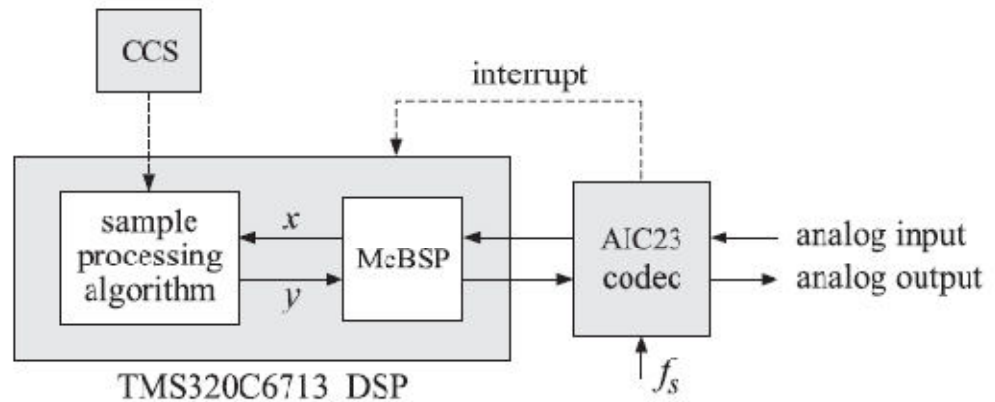

### *TMS320C6713 floating point DSP*

The AIC23 codec is configured (through CCS) to operate at one of the above sampling rates  $f_s$ . Each collected sample is converted to a 16-bit two's complement integer (a **short** data type in C). The codec actually samples the audio input in stereo, that is, it collects two samples for the left and right channels

### ARCHITECTURE

The 67XX DSPs use an advanced, modified Harvard architecture that maximizes processing power by maintaining one program memory bus and three data memory buses. These processors also provide an arithmetic logic unit (ALU) that has a high degree of parallelism, application-specific hardware logic, on-chip memory, and additional on-chip peripherals. These DSP families also provide a highly specialized instruction set, which is the basis of the operational flexibility and speed of these DSPs. Separate program and data spaces allow simultaneous access to program instructions and data, providing the high degree of parallelism. Two reads and one write operation can be performed in a single cycle. Instructions with parallel store and application-specific instructions can fully utilize this architecture. In addition, data can be transferred between data and program spaces. Such parallelism supports a powerful set of arithmetic, logic, and bit-manipulation operations that can all be performed in a single machine cycle. Also included are the control mechanisms to manage interrupts, repeated operations, and function calls.

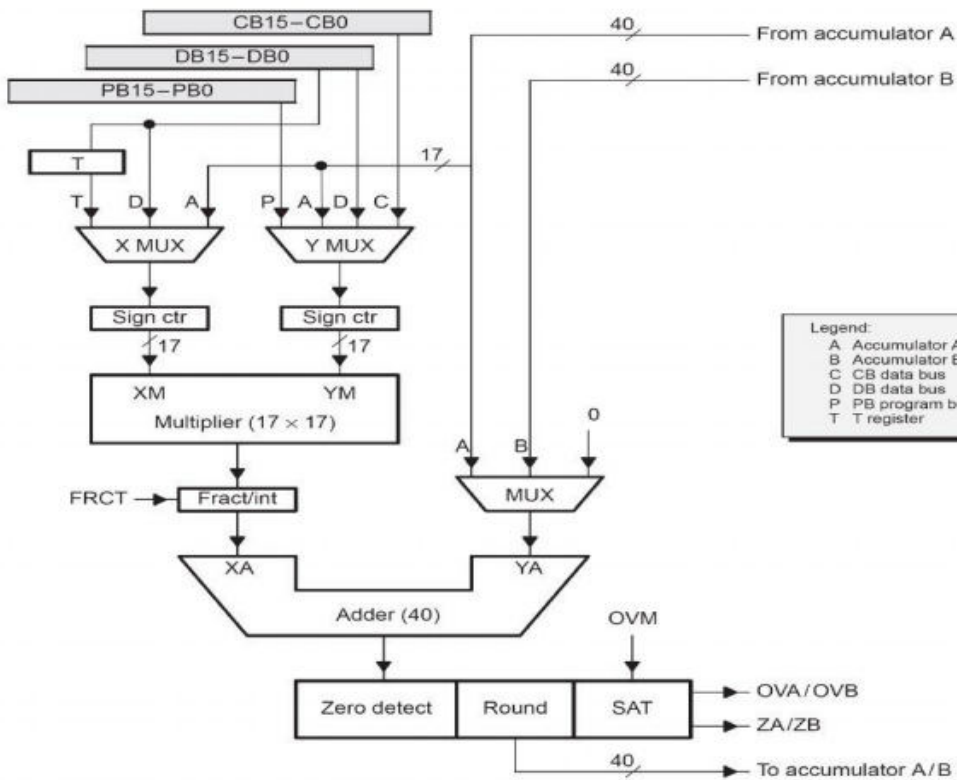
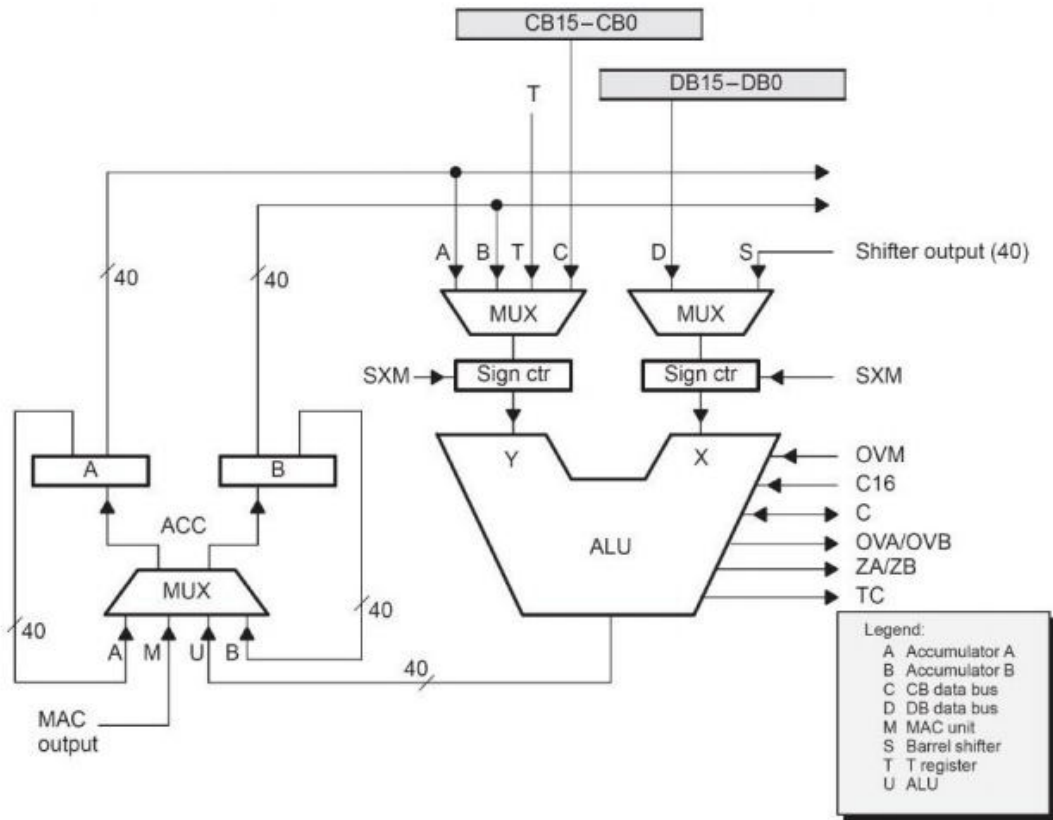

## **1. Central Processing Unit (CPU)**

The CPU of the “67XX devices contains:

- A 40-bit arithmetic logic unit (ALU)
- Two 40-bit accumulators
- A barrel shifter
- A 17-bit multiplier/adder
- A compare, select, and store unit (CSSU)

## **2. Arithmetic Logic Unit (ALU)**

The “67XX devices perform 2s-complement arithmetic using a 40-bit ALU and two 40-bit accumulators (ACCA and ACCB). The ALU also can perform Boolean operations. The ALU can function as two 16-bit ALUs and perform two 16-bit operations simultaneously when the C16 bit in status register 1 (ST1) is set.

## **3. Accumulators**

The accumulators, ACCA and ACCB, store the output from the ALU or the multiplier / adder block; the accumulators can also provide a second input to the ALU or the multiplier / adder. The bits in each accumulator are grouped as follows:

- Guard bits (bits 32–39)
- A high-order word (bits 16–31)
- A low-order word (bits 0–15)

Instructions are provided for storing the guard bits, the high-order and the low-order accumulator words in data memory, and for manipulating 32-bit accumulator words in or out of data memory. Also, any of the accumulators can be used as temporary storage for the other.

## **4. Barrel Shifter**

The “67XX”s barrel shifter has a 40-bit input connected to the accumulator or data memory (CB, DB) and a 40-bit output connected to the ALU or data memory (EB). The barrel shifter produces a left shift of 0 to 31 bits and a right shift of 0 to 16 bits on the input data. The shift requirements are defined in the shift-count field (ASM) of ST1 or defined in the temporary register (TREG), which is designated as a shift-count register. This shifter and the exponent detector normalize the values in an accumulator in a single cycle. The least significant bits (LSBs) of the output are filled with 0s and the most significant bits (MSBs) can be either zero-filled or sign-extended, depending on the state of the sign-extended mode bit (SXM) of ST1.

Additional shift capabilities enable the processor to perform numerical scaling, bit extraction, extended arithmetic, and overflow prevention operations

### **5. Multiplier/Adder**

The multiplier / adder perform 17-bit 2s-complement multiplication with a 40-bit accumulation in a single instruction cycle. The multiplier / adder block consists of several elements: a multiplier, adder, signed/unsigned input control, fractional control, a zero detector, a rounder (2s-complement), overflow/saturation logic, and TREG. The multiplier has two inputs: one input is selected from the TREG, a data memory operand, or an accumulator; the other is selected from the program memory, the data memory, an accumulator, or an immediate value. The fast on-chip multiplier allows the C67XX to perform operations such as convolution, correlation, and filtering efficiently. In addition, the multiplier and ALU together execute multiply/accumulate (MAC) computations and ALU operations in parallel in a single instruction cycle. This function is used in determining the Euclid distance, and in implementing symmetrical and least mean square (LMS) filters, which are required for complex DSP algorithms.

### **6. Compare, Select, and Store Unit (CSSU)**

The compare, select, and store unit (CSSU) performs maximum comparisons between the accumulator's high and low words, allows the test/control (TC) flag bit of status register 0 (ST0) and the transition (TRN) register to keep their transition histories, and selects the larger word in the accumulator to be stored in data memory. The CSSU also accelerates Viterbi-type butterfly computation with optimized on-chip hardware.

### **7. Program Control**

Program control is provided by several hardware and software mechanisms:

The program controller decodes instructions, manages the pipeline, stores the status of operations, and decodes conditional operations. Some of the hardware elements included in the program controller are the program counter, the status and control register, the stack, and the address-generation logic.

Some of the software mechanisms used for program control includes branches, calls, and conditional instructions, are peat instruction, reset, and interrupt.

The C67XX supports both the use of hardware and software interrupts for program control. Interrupt service routines are vectored through a re-locatable interrupt vector table. Interrupts can be globally enabled / disabled and can be

individually masked through the interrupt mask register (IMR). Pending interrupts are indicated in the interrupt flag register (IFR). For detailed information on the structure of the interrupt vector table, the IMR and the IFR, see the device-specific data sheets.

#### **8. Status Registers (ST0, ST1)**

The status registers, ST0 and ST1, contain the status of the various conditions and modes for the “67XX devices. ST0 contains the flags (OV, C, and TC) produced by arithmetic operations and bit manipulations in addition to the data page pointer (DP) and the auxiliary register pointer (ARP) fields. ST1 contains the various modes and instructions that the processor operates on and executes.

#### **9. Auxiliary Registers (AR0–AR7)**

The eight 16-bit auxiliary registers (AR0–AR7) can be accessed by the central arithmetic logic unit (CALU) and modified by the auxiliary register arithmetic units (ARAUs). The primary function of the auxiliary registers is generating 16-bit addresses for data space. However, these registers also can act as general-purpose registers or counters.

#### **10. Temporary Register (TREG)**

The TREG is used to hold one of the multiplicands for multiply and multiply/accumulate instructions. It can hold a dynamic (execution-time programmable) shift count for instructions with a shift operation such as ADD, LD, and SUB. It also can hold a dynamic bit address for the BITT instruction. The EXP instruction stores the exponent value computed into the TREG, while the NORM instruction uses the TREG value to normalize the number. For ACS operation of Viterbi decoding, TREG holds branch metrics used by the DADST and DSADT instructions.

#### **11. Transition Register (TRN)**

The TRN is a 16-bit register that is used to hold the transition decision for the path to new metrics to perform the Viterbi algorithm. The CMPS (compare, select, max, and store) instruction updates the contents of the TRN based on the comparison between the accumulator high word and the accumulator low word.

#### **12. Stack-Pointer Register (SP)**

The SP is a 16-bit register that contains the address at the top of the system stack. The SP always points to the last element pushed onto the stack. The stack is manipulated by interrupts, traps, calls, returns, and the PUSHHD, PSHM, POPD, and POPM instructions. Pushes and pops of the stack pre decrement and post increment, respectively, all 16 bits of the SP.

### **13. Circular-Buffer-Size Register (BK)**

The 16-bit BK is used by the ARAUs in circular addressing to specify the data block size.

### **14. Block-Repeat Registers (BRC, RSA, REA)**

The block-repeat counter (BRC) is a 16-bit register used to specify the number of times a block of code is to be repeated when performing a block repeat. The block-repeat start address (RSA) is a 16-bit register containing the starting address of the block of program memory to be repeated when operating in the repeat mode. The 16-bit block-repeat end address (REA) contains the ending address if the block of program memory is to be repeated when operating in the repeat mode.

### **15. Interrupt Registers (IMR, IFR)**

The interrupt-mask register (IMR) is used to mask off specific interrupts individually at required times. The interrupt-flag register (IFR) indicates the current status of the interrupts.

### **16. Processor-Mode Status Register (PMST)**

The processor-mode status registers (PMST) controls memory configurations of the 67XX devices.

### **17. Power-Down Modes**

There are three power-down modes, activated by the IDLE1, IDLE2, and IDLE3 instructions. In these modes, the “67XX devices enter a dormant state and dissipate considerably less power than in normal operation. The IDLE1 instruction is used to shut down the CPU. The IDLE2 instruction is used to shut down the CPU and on-chip peripherals. The IDLE3 instruction is used to shut down the “67XX processor completely. This instruction stops the PLL circuitry as well as the CPU and peripherals.

## **RESULT**

Thus the study of architecture TMS320VC67XX and its functionalities has been identified.

**Ex. No: 10**

**Date:**

**MAC OPERATION USING VARIOUS ADDRESSING MODES**

**AIM:**

To Study the various addressing modes of TMS320C67XX DSP processor.

**THEORY:**

**Addressing Modes** The TMS320C67XX DSP supports three types of addressing modes that enable flexible access to data memory, to memory-mapped registers, to register bits, and to I/O space:

The absolute addressing mode allows you to reference a location by supplying all or part of an address as a constant in an instruction.

The direct addressing mode allows you to reference a location using an address offset.

The indirect addressing mode allows you to reference a location using a pointer.

Each addressing mode provides one or more types of operands. An instruction that supports an addressing-mode operand has one of the following syntax elements listed below.

**Baddr**

When an instruction contains Baddr, that instruction can access one or two bits in an accumulator (AC0–AC3), an auxiliary register (AR0–AR7), or a temporary register (T0–T3). Only the register bit test/set/clear/complement instructions support Baddr. As you write one of these instructions, replace Baddr with a compatible operand.

**Cmem**

When an instruction contains Cmem, that instruction can access a single word (16 bits) of data from data memory. As you write the instruction, replace Cmem with a compatible operand.

**Lmem**

When an instruction contains Lmem, that instruction can access a long word (32 bits) of data from data memory or from a memory-mapped registers. As you write the instruction, replace Lmem with a compatible operand.

**Smem**

When an instruction contains Smem, that instruction can access a single word (16 bits) of data from data memory, from I/O space, or from a memory-mapped register. As you write the instruction, replace Smem with a compatible operand.

### **Xmem and Ymem**

When an instruction contains Xmem and Ymem, that instruction can perform two simultaneous 16-bit accesses to data memory. As you write the instruction, replace Xmem and Ymem with compatible operands.

### **Absolute Addressing Modes k16 absolute**

This mode uses the 7-bit register called DPH (high part of the extended data page register) and a 16-bit unsigned constant to form a 23-bit data space address. This mode is used to access a memory location or a memory-mapped register.

### **k23 absolute**

This mode enables you to specify a full address as a 23-bit unsigned constant. This mode is used to access a memory location or a memory-mapped register.

### **I/O absolute**

This mode enables you to specify an I/O address as a 16-bit unsigned constant. This mode is used to access a location in I/O space.

### **Direct Addressing Modes DP direct**

This mode uses the main data page specified by DPH (high part of the extended data page register) in conjunction with the data page register (DP). This mode is used to access a memory location or a memory-mapped register.

### **SP direct**

This mode uses the main data page specified by SPH (high part of the extended stack pointers) in conjunction with the data stack pointer (SP). This mode is used to access stack values in data memory.

### **Register-bit direct**

This mode uses an offset to specify a bit address. This mode is used to access one register bit or two adjacent register bits.

### **PDP direct**

This mode uses the peripheral data page register (PDP) and an offset to specify an I/O address. This mode is used to access a location in I/O space. The DP direct and SP direct addressing modes are mutually exclusive. The mode selected depends on the CPL bit in status register ST1\_67: 0 DP direct addressing mode 1 SP direct addressing mode The register-bit and PDP direct addressing modes are independent of the CPL bit.

### **Indirect Addressing Modes**

You may use these modes for linear addressing or circular addressing.

### **AR indirect**

This mode uses one of eight auxiliary registers (AR0–AR7) to point to data. The way the CPU uses the auxiliary register to generate an address depends on whether you are accessing data space (memory or memory-mapped registers), individual register bits, or I/O space.

### **Dual AR indirect**

This mode uses the same address-generation process as the AR indirect addressing mode. This mode is used with instructions that access two or more data-memory locations.

### **CDP indirect**

This mode uses the coefficient data pointer (CDP) to point to data. The way the CPU uses CDP to generate an address depends on whether you are accessing data space (memory or memory-mapped registers), individual register bits, or I/O space.

### **Coefficient indirect**

This mode uses the same address-generation process as the CDP indirect addressing mode. This mode is available to support instructions that can access a coefficient in data memory at the same time they access two other data-memory values using the dual AR indirect addressing mode.

### **Circular Addressing**

Circular addressing can be used with any of the indirect addressing modes. Each of the eight auxiliary registers (AR0–AR7) and the coefficient data pointer (CDP) can be independently configured to be linearly or circularly modified as they act as pointers to data or to register bits, see Table 3–10. This configuration is done with a bit (ARnLC) in status register ST2\_67. To choose circular modification, set the bit. Each auxiliary register ARn has its own linear/circular configuration bit in ST2\_67: 0 Linear addressing 1 Circular addressing The CDPLC bit in status register ST2\_67 configures the DSP to use CDP for linear addressing or circular addressing: 0 Linear addressing 1 Circular addressing You can use the circular addressing instruction qualifier, .CR, if you want every pointer used by the instruction to be modified circularly, just add .CR to the end of the instruction mnemonic (for example, ADD.CR). The circular addressing instruction qualifier overrides the linear/circular configuration in ST2\_67.

**ADDITION:**

```
INP1 .SET 0H
INP2 .SET 1H
OUT .SET 2H
      .mmregs
      .text
START:
      LD #140H,DP
      RSBX CPL
      NOP
      NOP
      NOP
      NOP
      LD INP1,A
      ADD INP2,A
      STL A,OUT
HLT: B HLT
```

**INPUT:**

Data Memory:  
A000h 0004h  
A001h 0004h

**OUTPUT:**

Data Memory:  
A002h 0008h

**SUBTRACTION:**

```
INP1 .SET 0H
INP2 .SET 1H
OUT .SET 2H
      .mmregs
      .text
START:
      LD #140H,DP
      RSBX CPL
      NOP
      NOP
      NOP
      NOP
      LD INP1,A
      SUB INP2,A
      STL A,OUT
HLT: B HLT
```

**INPUT:**

Data Memory:  
A000h 0004h  
A001h 0002h

**OUTPUT:**

Data Memory:  
A002h 0002h

**RESULT:**

Thus, the various addressing mode of DSP processor TMS320C67XX was studied.

**Ex. No: 11**

**Date:**

### **LINEAR CONVOLUTION**

**AIM:**

To perform the Linear Convolution of two given discrete sequence in TMS320C67XX.

**APPARATUS REQUIRED:**

HARDWARE : Personal Computer & TMS320C67XX kit

SOFTWARE : Code Composer Studio version4

**PROCEDURE:**

1. Open Code Composer Studio v4.
2. To create the New Project  
Project→ New (File Name. pjf, Eg: vvits.pjf)
3. To create a Source file  
File →New→ Type the code (Save & give file name, Eg: sum.c).
4. To Add Source files to Project  
Project→ Add files to Project→ sum.c
5. To Add rts.lib file & Hello.cmd:  
Project→ Add files to Project→ rts6700.lib  
Library files: rts6700.lib (Path: c:\ti\c6000\cgtools\lib\ rts6700.lib)  
Note: Select Object& Library in (\*.o,\*.l) in Type of files
6. Project→ Add files to Project →hello.cmd  
CMD file - Which is common for all non real time programs.  
(Path: c:\ti \ tutorial\dsk6713\hello1\hello.cmd)  
Note: Select Linker Command file (\*.cmd) in Type of files

**Compile:-**

1. To Compile: Project→\_Compile
2. To Rebuild: project → rebuild,  
Which will create the final .out executable file. ( Eg. vvit.out).
3. Procedure to Lode and Run program:  
Load the Program to DSK: File→ Load program →vvit.out  
To Execute project: Debug → Run

**PROGRAM:** (Linear Convolution)

```
#include<stdio.h>
int m=6;
    int n=6;
    int i=0, j;
    int x[15]={1,2,3,4,5,6,0,0,0,0,0,0};
    int h[15]={1,2,3,4,5,6,0,0,0,0,0,0};
    int y[20];
main()
{
    for(i=0;i<m+n-1;i++)
    {
        y[i]=0;
        for(j=0;j<=i;j++)
            y[i]+=x[j]*h[i-j];
    }
    for(i=0;i<m+n-1;i++)
        printf("%d \n",y[i]);
}
```

**OUTPUT: (Linear Convolution)**

4      10      20      35      56      70      76      73      60      36

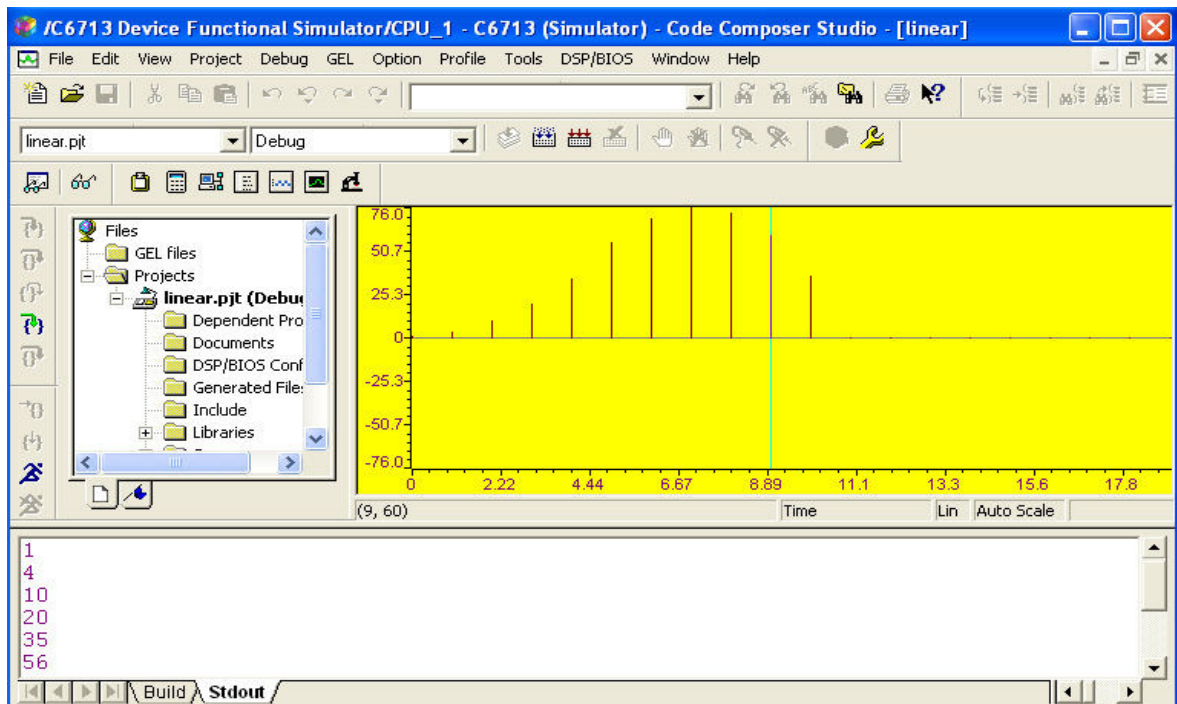
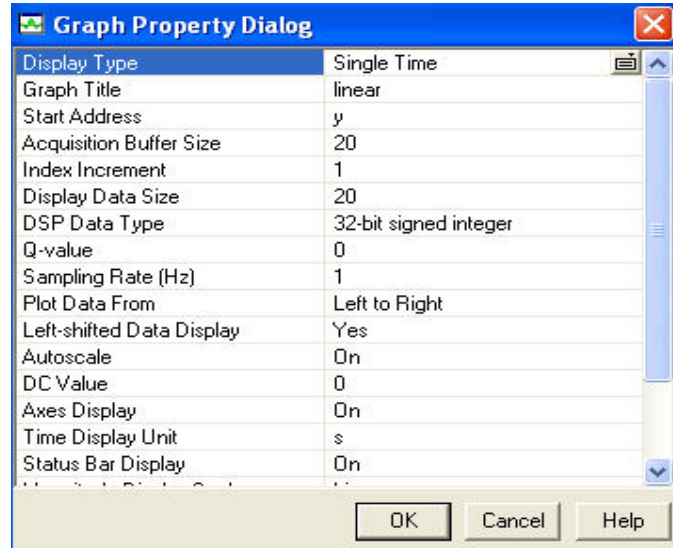

**RESULTS:**

Thus the C- Program for Linear convolution was written and the output was verified.

**Ex. No: 12**

**Date:**

## **CIRCULAR CONVOLUTION**

### **AIM:**

To perform the circular Convolution of two given discrete sequences in TMS320C67XX.

### **APPARATUS REQUIRED:**

HARDWARE : Personal Computer & TMS320C67XX kit

SOFTWARE : Code Composer Studio version4

### **PROCEDURE:**

1. Open Code Composer Studio v4.
2. To create the New Project  
Project→ New (File Name. pjt, Eg: vvits.pjt)
3. To create a Source file  
File →New→ Type the code (Save & give file name, Eg: sum.c).
4. To Add Source files to Project  
Project→ Add files to Project→ sum.c
5. To Add rts.lib file & Hello.cmd:  
Project→ Add files to Project→ rts6700.lib  
Library files: rts6700.lib (Path: c:\ti\c6000\cgtools\lib\ rts6700.lib)  
Note: Select Object& Library in (\*.o,\*.l) in Type of files
6. Project→ Add files to Project →hello.cmd  
CMD file - Which is common for all non real time programs.  
(Path: c:\ti \ tutorial\dsk6713\hello1\hello.cmd)  
Note: Select Linker Command file (\*.cmd) in Type of files

### **COMPILE:**

1. To Compile: Project→\_Compile
2. To Rebuild: project → rebuild,  
Which will create the final .out executable file. ( Eg. vvit.out).
3. Procedure to Lode and Run program:  
Load the Program to DSK: File→ Load program →vvit.out  
To Execute project: Debug → Run

**PROGRAM:** (Circular Convolution)

```
#include<stdio.h>
int
m,n,x[30],h[30],y[30],i,j,temp[30],k,x2[30],a[30];
void main()
{
printf("enter the length of the 1st sequence\n");
scanf("%d",&m);
printf("enter the length of the second sequence\n");
scanf("%d",&n);
printf("enter the 1st sequence\n");
for(i=0;i<m;i++)
scanf("%d",&x[i]);
printf("enter the second sequence\n");
for(j=0;j<n;j++)
scanf("%d",&h[j]);
if(m-n!=0)
{
if(m>n)
{
for(i=n;i<m;i++)
h[i]=0;
n=m;
}
for(i=m;i<n;i++)
x[i]=0;
m=n;
}
y[0]=0;
a[0]=h[0];
for(j=1;j<n;j++)
a[j]=h[n-j];
for(i=0;i<n;i++)
y[0]+=x[i]*a[i];
for(k=1;k<n;k++)
{
y[k]=0;
for(j=1;j<n;j++)
x2[j]=a[j-1];
x2[0]=a[n-1];
for(i=0;i<n;i++)
{
a[i]=x2[i];
y[k]+=x[i]*x2[i];
}
}
printf("the circular convolution is\n");
for(i=0;i<n;i++)
printf("%d\t",y[i]);
}
```

**INPUT: (Circular Convolution)**

Enter the length of the 1st sequence 5  
Enter the length of the second sequence 5  
Enter the 1st sequence 1 2 3 4 5  
Enter the second sequence 1 2 3 4 5

**OUTPUT:**

The circular convolution is

45 50 50 45 35

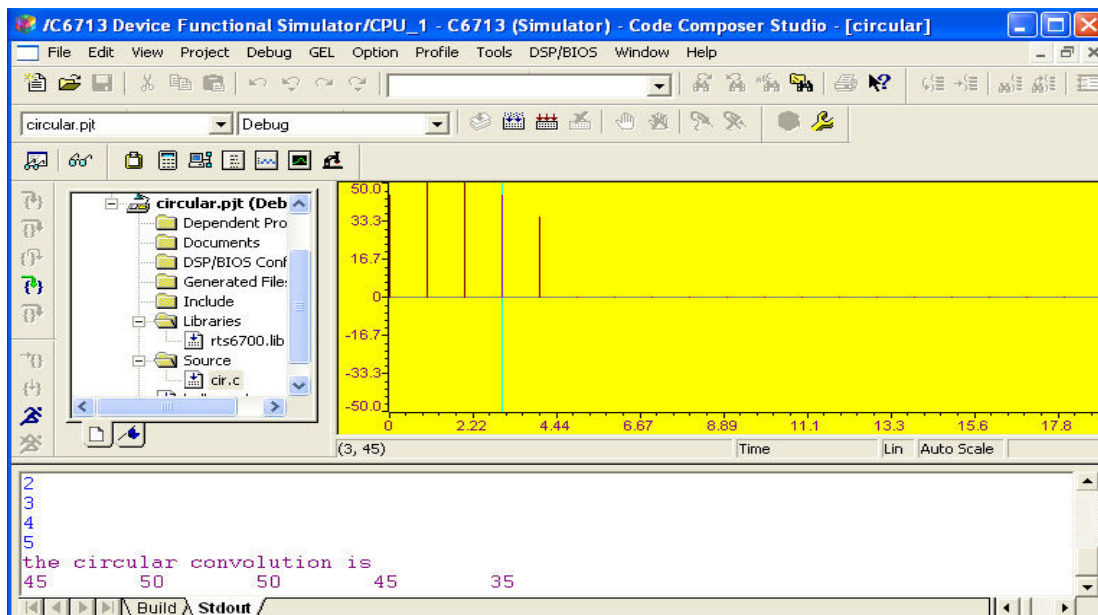
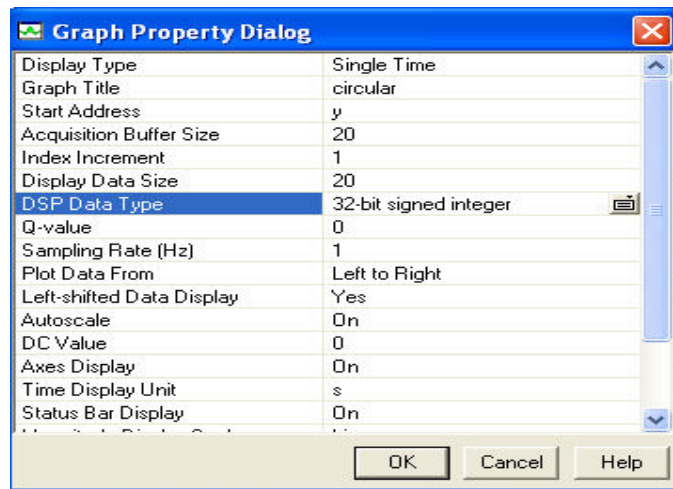

**RESULT:**

Thus the C- Program for Circular convolution was written and the output was verified.

**Ex. No: 13**

**Date:**

**FFT IMPLEMENTATION**

**AIM:**

To write a C- program to compute 8 – FFT of given sequences using DIF – FFT algorithm in TMS320C67XX.

**APPARATUS REQUIRED:**

HARDWARE : Personal Computer & TMS320C67XX kit

SOFTWARE : Code Composer Studio version4

**PROCEDURE:**

1. Open Code Composer Studio v4.
2. To create the New Project  
Project→ New (File Name. pjf, Eg: vvits.pjf)
3. To create a Source file  
File →New→ Type the code (Save & give file name, Eg: sum.c).
4. To Add Source files to Project  
Project→ Add files to Project→ sum.c
5. To Add rts.lib file & Hello.cmd:  
Project→ Add files to Project→ rts6700.lib  
Library files: rts6700.lib (Path: c:\ti\c6000\cgtools\lib\ rts6700.lib)  
Note: Select Object& Library in (\*.o,\*.l) in Type of files
6. Project→ Add files to Project →hello.cmd  
CMD file - Which is common for all non real time programs.  
(Path: c:\ti \ tutorial\dsk6713\hello1\hello.cmd)  
Note: Select Linker Command file (\*.cmd) in Type of files

**COMPILE:**

1. To Compile: Project→\_Compile
2. To Rebuild: project → rebuild,  
Which will create the final .out executable file. ( Eg. vvit.out).
3. Procedure to Lode and Run program:  
Load the Program to DSK: File→ Load program →vvit.out  
To Execute project: Debug → Run

**PROGRAM:** (FFT Implementation)

```

#include<stdio.h>
#include<math.h>
#define N 8
#define PI 3.14159
typedef struct
{
    float real, imag;
}
    complex;
main()
{
    int i;
    complex w[N];
    complex
x[8]={0,0.0,1,0.0,2,0.0,3,0.0,4,0.0,5,0.0,6,0.0,7,0.0};
    complex temp1,temp2;
    int j,k,upper_leg,lower_leg,leg_diff,index,step;
for(i=0;i<N;i++)
{
    w[i].real=cos((2*PI*i)/(N*2.0));
    w[i].imag=-sin((2*PI*i)/(N*2.0));
}
    leg_diff=N/2;
    step=2;
for(i=0;i<3;i++)
{
    index=0;
for(j=0;j<leg_diff;j++)
{
for(upper_leg=j;upper_leg<N;upper_leg+=(2*leg_diff))
{
lower_leg=upper_leg+leg_diff;
temp1.real=(x[upper_leg]).real+(x[lower_leg]).real;
temp1.imag=(x[upper_leg]).imag+(x[lower_leg]).imag;
temp2.real=(x[upper_leg]).real-(x[lower_leg]).real;
temp2.imag=(x[upper_leg]).imag-(x[lower_leg]).imag;
(x[lower_leg]).real=temp2.real*(w[index]).real-
temp2.imag*(w[index]).imag;
(x[lower_leg]).imag=temp2.real*(w[index]).imag+temp2.imag
*(w[index]).real;
(x[upper_leg]).real=temp1.real;
(x[upper_leg]).imag=temp1.imag;
}
        index+=step;
}
        leg_diff=(leg_diff)/2;
        step=step*2;
}
    j=0;
for(i=1;i<(N-1);i++)
{

```

```
    k=N/2;
    while(k<=j)
    {
        j=j-k;
        k=k/2;
    }
    j=j+k;
    if(i<j)
    {
        temp1.real=(x[j]).real;
        temp1.imag=(x[j]).imag;
        (x[j]).real=(x[i]).real;
        (x[j]).imag=(x[i]).imag;
        (x[i]).real=temp1.real;
        (x[i]).imag=temp1.imag;
    }
}

printf("the fft of the given input sequence is \n");
for(i=0;i<8;i++)
{
    printf("%f %f \n", (x[i]).real, (x[i]).imag);
}
}
```

**OUTPUT: (FFT Implementation)**

The FFT of the given input sequence is:

28.000000	0.000000
-4.000012	9.656858
-4.000005	4.000000
-4.000010	1.656851
-4.000000	0.000000
-3.999998	-1.656858
-3.999995	-4.000000
-3.999980	-9.656851

**RESULT:**

Thus the C- Program for Circular convolution was written and the output was verified.

**Ex. No: 14**

**Date:**

### **WAVEFORM GENERATION**

**AIM:**

To generate a sine wave and square wave using TMS320C67XX DSP KIT.

**APPARATUS REQUIRED:**

HARDWARE : Personal Computer & TMS320C67XX kit

SOFTWARE : Code Composer Studio version4

**PROCEDURE:**

1. Open Code Composer Studio v4.
2. To create the New Project  
Project→ New (File Name. pjt, Eg: vvits.pjt)
3. To create a Source file  
File →New→ Type the code (Save & give file name, Eg: sum.c).
4. To Add Source files to Project  
Project→ Add files to Project→ sum.c
5. To Add rts.lib file & Hello.cmd:  
Project→ Add files to Project→ rts6700.lib  
Library files: rts6700.lib (Path: c:\ti\c6000\cgtools\lib\ rts6700.lib)
6. Project→ Add files to Project →hello.cmd  
CMD file - Which is common for all non real time programs.  
(Path: c:\ti \ tutorial\dsk6713\hello1\hello.cmd)  
Note: Select Linker Command file (\*.cmd) in Type of files

**COMPILE:**

1. To Compile: Project→\_Compile
2. To Rebuild: project → rebuild,  
Which will create the final .out executable file. ( Eg. vvit.out).
3. Procedure to Lode and Run program:  
Load the Program to DSK: File→ Load program →vvit.out  
To Execute project: Debug → Run

**PROGRAM:** (Sine waveform)

```
#include <stdio.h>
#include <math.h>
float a[500];
void main()
{
    int i=0;
    for(i=0;i<500;i++)
    {
        a[i]=sin(2*3.14*10000*i);
    }
}
```

**OUTPUT:** ( Sine waveform)

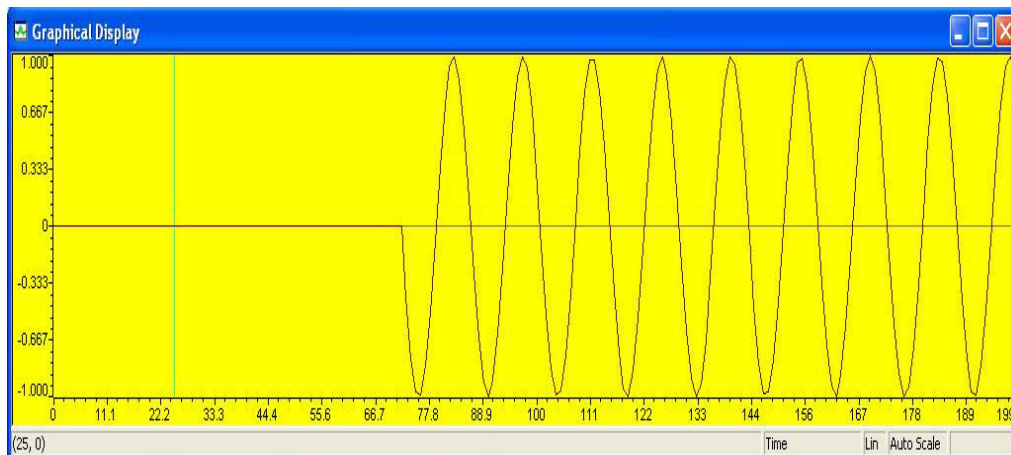
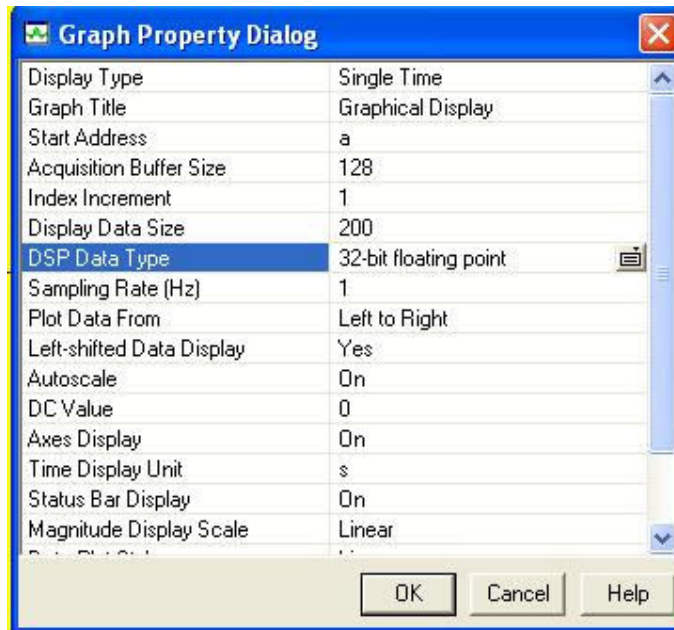

**PROGRAM:** ( Square waveform)

```
#include <stdio.h>
#include <math.h>
int a[1000];
void main()
{
    int i,j=0;
    int b=5;
    for(i=0;i<10;i++)
    {
        for (j=0;j<=50;j++)
        {
            a[(50*i)+j]=b;
        }
        b=b*(-1) ;
    }
}
```

**OUTPUT:** ( Square waveform)

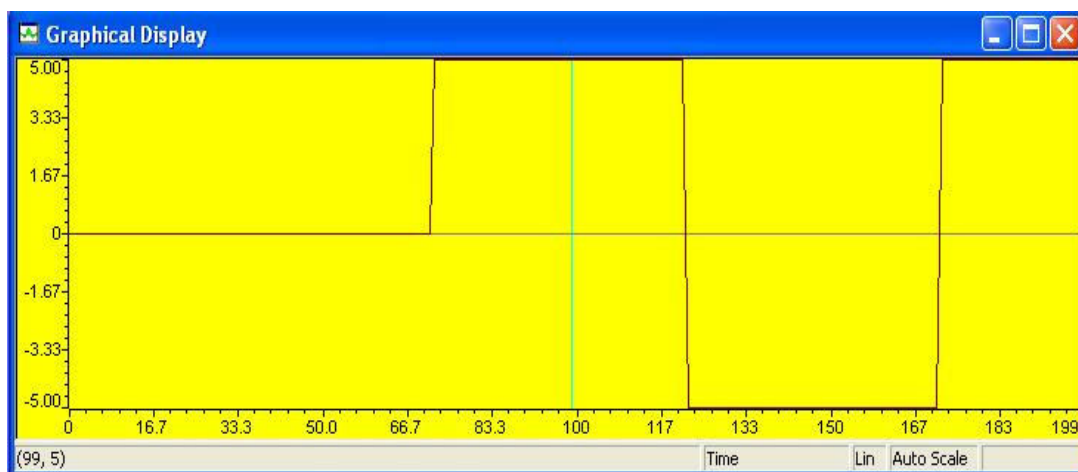
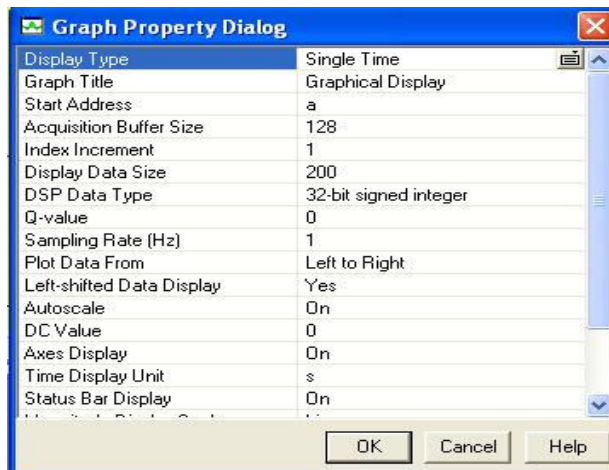

**RESULT:**

Thus, the sine wave and square waveform was generated displayed at graph.

**Ex. No: 15a**

**Date:**

## **DESIGN OF FIR FILTERS**

**AIM:**

To write a C program for the design of FIR Filter, also plots the magnitude responses for the same.

**APPARATUS REQUIRED:**

HARDWARE : Personal Computer & TMS320C67XX kit

SOFTWARE : Code Composer Studio version4

**PROCEDURE:**

1. Open Code Composer Studio v4.
2. To create the New Project  
Project→ New (File Name. pjt, Eg: vvits.pjt)
3. To create a Source file  
File →New→ Type the code (Save & give file name, Eg: sum.c).
4. To Add Source files to Project  
Project→ Add files to Project→ sum.c
5. To Add rts.lib file & Hello.cmd:  
Project→ Add files to Project→ rts6700.lib  
Library files: rts6700.lib (Path: c:\ti\c6000\cgtools\lib\ rts6700.lib)  
Note: Select Object& Library in (\*.o,\*.l) in Type of files
6. Project→ Add files to Project →hello.cmd  
CMD file - Which is common for all non real time programs.  
(Path: c:\ti \ tutorial\dsk6713\hello1\hello.cmd)  
Note: Select Linker Command file (\*.cmd) in Type of files

**COMPILE:**

1. To Compile: Project→\_Compile
2. To Rebuild: project → rebuild,  
Which will create the final .out executable file. ( Eg. vvit.out).
3. Procedure to Lode and Run program:  
Load the Program to DSK: File→ Load program →vvit.out  
To Execute project: Debug → Run

**PROGRAM:** (FIR Filters)

```
#include<stdio.h>
#include<math.h>
#define pi 3.1415
int n,N,c;
float wr[64],wt[64];
void main()
{
    printf("\n enter no. of samples,N= :");
    scanf("%d",&N);
    printf("\n enter choice of window function\n 1.rect
\n 2. triang \n c= :");
    scanf("%d",&c);
    printf("\n elements of window function are:");
    switch(c)
    {
        case 1:
        for(n=0;n<=N-1;n++)
        {
            wr[n]=1;
            printf(" \n wr[%d]=%f",n,wr[n]);
        }
        break;
        case 2:
        for(n=0;n<=N-1;n++)
        {
            wt[n]=1-(2*(float)n/(N-1));
            printf("\n wt[%d]=%f",n,wt[n]);
        }
        break;
    }
}
```

**OUTPUT: (FIR Filters)**

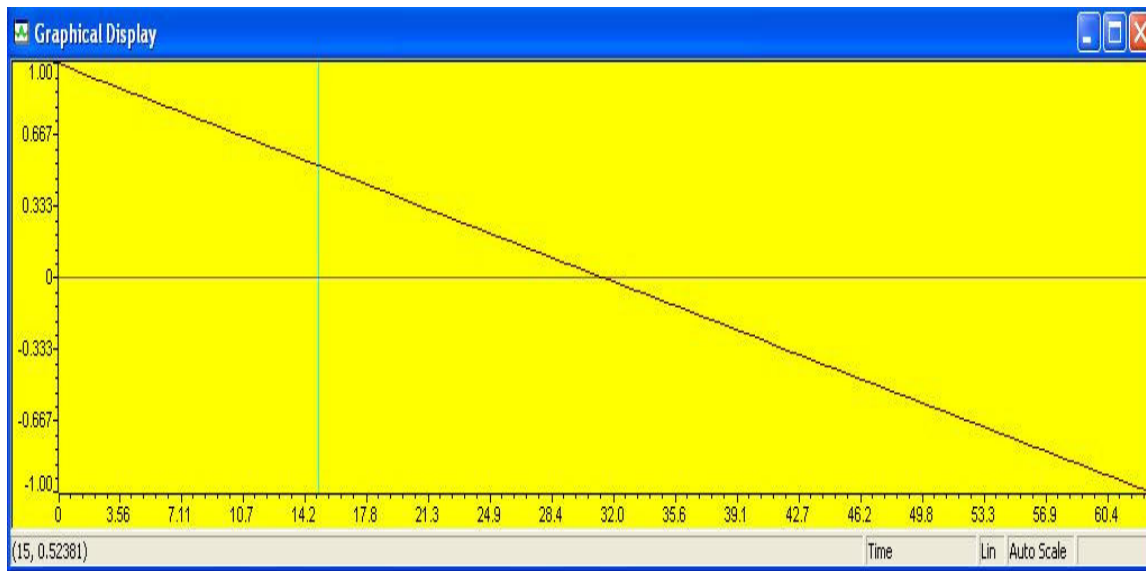
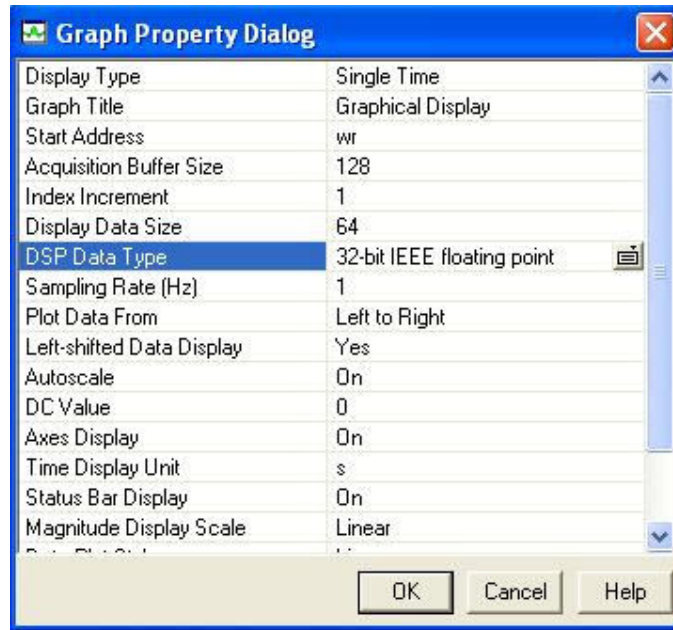

**RESULT:**

Thus the C program for the design of FIR filter was plotted successfully.

**Ex. No: 15b**

**Date:**

## **DESIGN OF IIR FILTERS**

**AIM:**

To write a C program for the design of IIR Filter, also plots the magnitude responses for the same.

**APPARATUS REQUIRED:**

HARDWARE : Personal Computer & TMS320C67XX kit

SOFTWARE : Code Composer Studio version4

**PROCEDURE:**

1. Open Code Composer Studio v4.
2. To create the New Project  
Project→ New (File Name. pjf, Eg: vvits.pjf)
3. To create a Source file  
File →New→ Type the code (Save & give file name, Eg: sum.c).
4. To Add Source files to Project  
Project→ Add files to Project→ sum.c
5. To Add rts.lib file & Hello.cmd:  
Project→ Add files to Project→ rts6700.lib  
Library files: rts6700.lib (Path: c:\ti\c6000\cgtools\lib\ rts6700.lib)  
Note: Select Object& Library in (\*.o,\*.l) in Type of files
6. Project→ Add files to Project →hello.cmd  
CMD file - Which is common for all non real time programs.  
(Path: c:\ti \ tutorial\dsk6713\hello1\hello.cmd)  
Note: Select Linker Command file (\*.cmd) in Type of files

**COMPILE:**

1. To Compile: Project→\_Compile
2. To Rebuild: project → rebuild,  
Which will create the final .out executable file. ( Eg. vvit.out).
3. Procedure to Load and Run program:  
Load the Program to DSK: File→ Load program →vvit.out  
To Execute project: Debug → Run

**PROGRAM:** (IIR Filters)

```
#include<stdio.h>
#include<math.h>
int i,w,wc,c,N;
float H[100];
float mul(float,int);
void main()
{
printf("\n Enter order of filter");
scanf("%d",&N);
printf("\n Enter the cut off frequency");
scanf("%d",&wc);
printf("\n Enter the choice for IIR Filter 1.LPF 2.HPF");
scanf("%d",&c);
switch(c)
{
case 1:
for(w=0;w<100;w++)
{
H[w]=1/sqrt(1+mul((w/(float)wc),2*N));
printf("H[%d]=%f\n",w,H[w]);
}
break;
case 2:
for(w=0;w<=100;w++)
{
H[w]=1/sqrt(1+mul((float)wc/w,2*N));
printf("H[%d]=%f\n",w,H[w]);
}
break;
}
}
float mul(float a,int x)
{
for(i=0;i<x-1;i++)
a*=a;
return(a); }
```

**INPUT:** (IIR Filters)

```
Enter order of filter      2
Enter the cut off frequency      50
Enter the choice for IIR Filter 1.LPF 2.HPF:      1
```

**OUTPUT: (IIR Filters)**

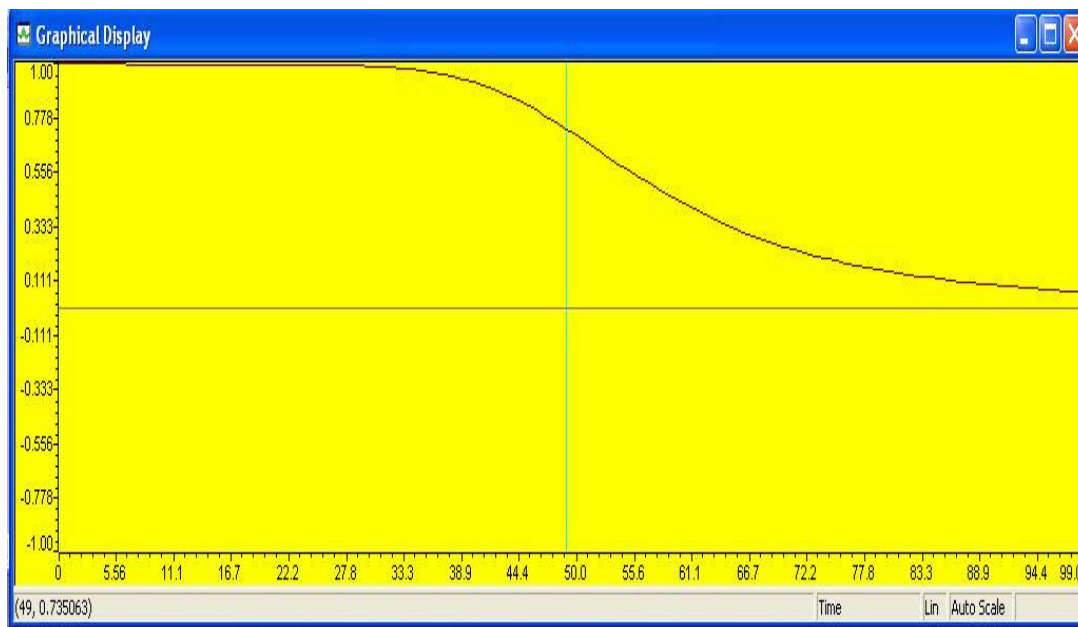
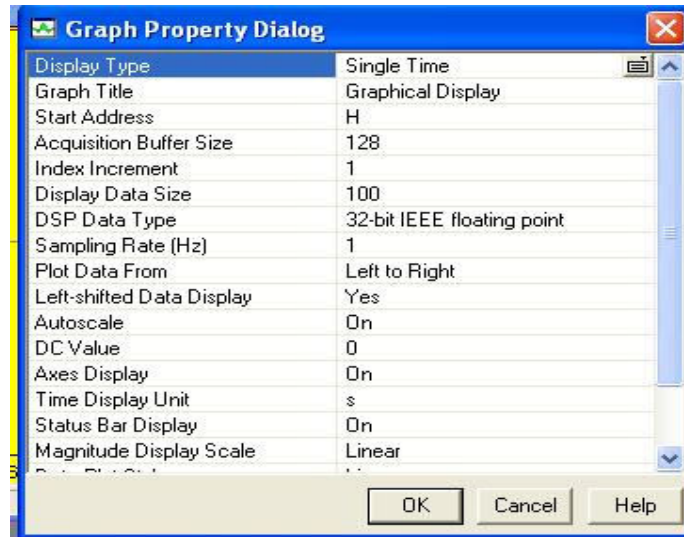

**RESULT:**

Thus the C program for the design of IIR filter were plotted successfully.

**Ex. No:16**

**Date:**

**ANALYSIS OF FINITE WORD LENGTH EFFECT IN  
FIXED POINT DSP SYSTEMS**

**AIM:**

To study the functions of finite word length effect in fixed point DSP systems.

**APPARATUS REQUIRED:**

HARDWARE : Personal Computer & TMS320C67XX kit

SOFTWARE : Code Composer Studio version4

**FUNCTIONS:**

```
function ADCNoiseGain=ADCNoise(b,a,n,FM)
    [B,A] = sos2tf([b a]); %form A(z) and B(z)
    [h,t] = impz(B,A,n);
    ADCNoiseGain = sum(h.^2)/12.0;
    fprintf('ADC noise gain is %f\n\n',ADCNoiseGain);
    if FM~=1
        fprintf('ADC noise is %g^2*%g*q^2\n', [FM ADCNoiseGain]);
    else
        fprintf('ADC noise is %g*q^2\n',ADCNoiseGain);
    end
function CoeffQuantizeErr(b,a,maxbits,ftype,f,Fs)

%COEFFICIENT QUANTIZATION ERROR ANALYSIS
n=256;
for nbits=2:maxbits
    [B,A]=QuantizeCoeff(b,a,nbits);
    [B,A] = sos2tf([B A]);
    [h,w] = freqz(B,A,n);
    amag = abs(h);
        amag = amag/max(amag); response
dev(nbits-1,:) = RippleAtten(ftype,f,amag,n,Fs);
fprintf('nbits\tband1\t\tband2\t\tband3\n');
fprintf('%d\t%f\t%f\t%f\n', reshape([(2:maxbits) '
dev'],maxbits-1,4));
fprintf('\nfrequency response with quantization noise for
desired wordlength:\n');
nbits=input('          wordlength (32 for unquantized
coefficients): ');
    [B,A] = sos2tf([b a]);
    freqz(B,A,n);
    hold on;
    [B,A] = QuantizeCoeff(b,a,nbits); [B,A] = sos2tf([B A]);
    freqz(B,A,n);
    title('Frequency Response for Desired Wordlength');
function Stability(b,a,maxbits)
format long;
```

```

fprintf('\n\nnbits\tstage\tA1\tA2\tradius1\tangle1\tradiu
s2\tangle2\n');
for nbits=2:maxbits
    [B,A]=QuantizeCoeff(b,a,nbits);
    for i=1:size(b,1)
        r1 = sqrt(abs(A(i,3)));
        angle1 = 180/pi*acos(A(i,2)/(-2.0*r1));
        r2 = sqrt(abs(a(i,3)));
        angle2 = 180/pi*acos(a(i,2)/(-2.0*r2));
fprintf('%d\t%d\t%-7.4f\t%-7.4f\t%-7.4f\t%-7.2f\t%-
7.4f\t%-
7.2f\n',nbits,i,A(i,2),A(i,3),r1,angle1,r2,angle2);
end
end
format;
function ScaleFactor(b,a,nstep,size,structure)
    norm0 = DirectScale(b,a,0,nstep);
    norm1 = DirectScale(b,a,1,nstep);
    norm2 = DirectScale(b,a,2,size);
else
    norm0 = CanonicScale(b,a,0,nstep);
    norm1 = CanonicScale(b,a,1,nstep);
    norm2 = CanonicScale(b,a,2,size);
end
disp('L1-norms of the second order sections:'); disp(norm0);
disp('L2-norms of the second order sections:'); disp(norm1);
disp('Loo-norms of the second order sections:'); disp(norm2);
function s = DirectScale(b,a,iopt,n)
if(iopt>=3)
s = ones(1,size(b,1));
return;
else
A = 1; B = 1;
for i=1:size(b,1) %loop for each stage
    A = conv(A,a(i,:));
B = conv(B,b(i,:));
s(i) = GetScaleFactor(B,A,iopt,n);
end
end
function s = CanonicScale(b,a,iopt,n)
if(iopt>=3)
s = ones(1,size(b,1));

return;
else
A = 1; B = 1;
for i=1:size(b,1)
    A = conv(A,a(i,:));
if i>1
    B = conv(B,b(i-1,:));
end
s(i) = GetScaleFactor(B,A,iopt,n);
end end

```

**RESULT:**

Thus the function of finite word length effect in fixed point DSP processor is studied.