



# **Varuwan Vadivelan**

## **Institute of Technology**

Dharmapuri – 636 703

### **LAB MANUAL**

**Regulation** : 2013  
**Branch** : All Branches  
**Year & Semester** : I Year / I Semester

**GE6163 – PHYSICS LABORATORY-I**



**Department of Physics**

**SYLLABUS**  
**ANNA UNIVERSITY: CHENNAI**  
**R - 2013**  
**PHYSICS LABORATORY**

**I-SEMESTER**

**LIST OF EXPERIMENTS (Any 5 Experiment)**

**1. Determination of Laser Parameters**

[A] Particle size determination by diode laser

[B] Wave length of laser

[C] Determination of Numerical aperture and Acceptance angle - optical fibre

**2. Determination of Ultrasonic interferometer**

**3. Determination of Spectrometer - Grating**

**4. Determination of Lee's Disc - Thermal conductivity of a bad conductor**

**5. Determination of Young's Modulus - Non uniform bending**

**6. Determination of Cary foster bridge**

## INDEX

<b>EX. NO</b>	<b>DATE</b>	<b>NAME OF THE EXPERIMENT</b>	<b>SIGNATURE OF THE STAFF</b>	<b>REMARKS</b>
<b>1</b>		<b>Laser Parameters</b> [A] Particle size determination by diode laser [B] Wave length of laser [C] Determination of Numerical aperture and Acceptance angle- optical fibre		
<b>2</b>		<b>Ultrasonic interferometer</b>		
<b>3</b>		<b>Spectrometer - Grating</b>		
<b>4</b>		<b>Lee's Disc - Thermal conductivity of a bad conductor</b>		
<b>5</b>		<b>Young's Modulus - Non uniform bending</b>		
<b>6</b>		<b>Cary foster bridge</b>		

## INSTRUCTION

### 1. LASER APPARATUS

#### PARTICLE SIZE

- The lycopodium powder dispersed in a transparent thin glass plate is kept vertically using a stand in between the laser source and screen.
- The laser beam incident on the glass plate undergoes diffraction by the particles.
- To obtain diffraction pattern of lycopodium powder using laser source glass.
- To measure the radius of the first and second order rings for various screen plate distances and calculate the particle size

#### WAVE LENGTH OF LASER

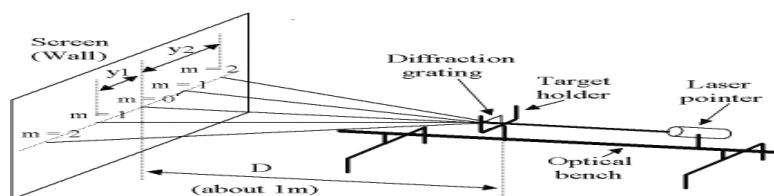

- To obtain diffraction spots on the screen using grating and the laser source an optical grating of known  $N$  value is fixed on the grating mount that is placed on a stand.
- Laser beam from the given semiconductor laser source is made to fall normally on the fixed grating.
- Now, the grating diffracts laser beam. A screen is kept on the other side of the grating to obtain the diffraction spots.
- The distance between the grating and screen is fixed.
- The distance between the centre spot and first order diffraction spot on either side of the screen is measured.
- The above procedure is repeated for different values.
- The distance between the diffracting slit and the first order diffraction spot is calculated and the mean value is found.
- The wavelength of the laser is calculated using the formula.

**NUMERICAL APERTURE AND ACCEPTANCE ANGLE**

- Mount Laser source.
- Mount both the ends of the optical fiber on the fiber holders.
- Couple the light from the laser source onto one of the fiber ends using a microscopic objective.
- Place the screen at some distance from the output end of the fiber such that it is perpendicular to the axis of the fiber.
- Now move the screen towards or away from the output end of the fiber such that circular beam emanating from the fiber end covers the 1st or 2nd or 3rd circle on the screen.
- Measure the distance between the output end of optical fiber and screen. Let this be  $L$ , also measure the diameter of the circular spot formed on the screen. Diameters are mentioned in mm.
- Use the formula's to calculate NA and V number for the fiber.

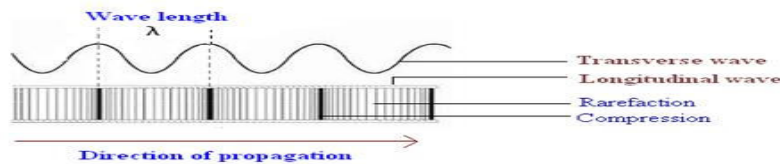
**2. ULTRASONIC INTERFEROMETER**

- An Ultrasonic interferometer is a simple and direct device to determine the ultrasonic velocity in liquids with high degree of accuracy. The principle used in the measurement of velocity ( $v$ ) is based on the accurate determination of the wavelength ( $\lambda$ ) in the medium.
- Choose medium select the desired experimental liquid.
- Using the slider Frequency of wave, set the frequency of the ultrasonic sound used. A lower frequency will give a longer wavelength, which is easier to measure accurately.
- Switch ON the frequency generator using the Power on button.
- Then adjust the GAIN and ADJ knobs such that the ADJ value is greater than GAIN value.
- At this micrometer setting the ammeter will show a maximum. Do not record the micrometer reading at this maximum. It could be inaccurate because the first maximum should be at zero and the micrometer cannot be set to zero.

- Right and left arrows are provided to increase or decrease the micrometer distance. Increase the micrometer setting till the anode current in the ammeter shows a new maximum.
- The distance between the adjacent maxima is calculated. From the equations, one can calculate the velocity of sound waves through the medium and also the adiabatic compressibility of the liquid can be calculated.

### 3. Spectrometer - Grating

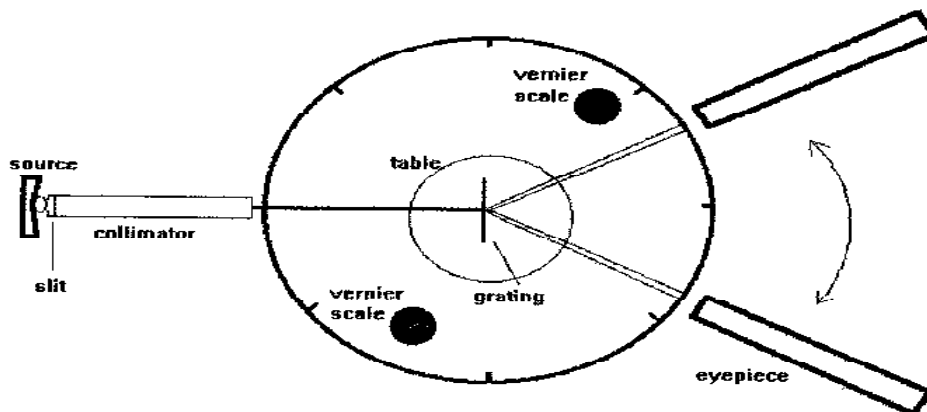

- The telescope eyepiece is adjusted so that the cross hairs are in sharp focus.
- The telescope is focused on a distant object so as to minimize parallax between the image and the crosshairs.
- At the same time this would ensure that the light entering the objective of the telescope is made up of parallel rays of light brought to focus on the crosshairs.
- The collimator slit is illuminated by the light source whose wavelength is to be measured.
- It is ensured that the telescope would be in direct line with the slit by seeing that the image of the slit is in sharp focus when observed through the telescope.
- The grating is then placed on the rotating table with the plane perpendicular to both the telescope and the collimator.
- The telescope is then rotated through  $90^\circ$  and then the table is turned until the grating reflects light onto the crosshairs of the telescope.
- The table is turned back exactly through  $45^\circ$  until it is again being illuminated normally by the light.
- The telescope is then moved circularly with the middle of the plane of the grating acting as its centre of rotation until the 1st maximum is seen on either side of the normal as shown below.

- The angle  $\theta$  between the first two order principal maxima is taken. Measuring the double angle rather than  $\theta$  gives half of the error.

### Lee's Disc - Thermal conductivity of a bad conductor

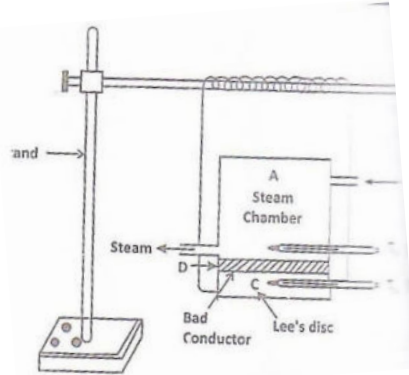

- The apparatus consists circular metal disc or slab by strings as stand. The given bad conductor is taken in the disc D.
- This disc has the same diameter as that of the slab and is placed over it.
- A cylindrical hollow steam chamber A having the same diameter as that of the slab is placed over the bad conductor.
- There are holes in the steam chamber and the slab through which thermometers  $T_1$  and  $T_2$  are inserted to record the respective temperatures.
- Steam is passed through the steam chamber until the maximum temperatures the chamber and the slabs are ready. When the thermometer show steady temperatures, there reading  $\theta_1$  and  $\theta_2$  are noted.
- The bad conductor is removed and the steam chamber is placed directly on the slab. The slab is heated to a temperature of about  $5^\circ\text{C}$  higher than  $\theta_2$ .
- The steam chamber is removed and the slab alone is allowed to cool.
- As the slab cools, the temperatures of the slab are noted at regular intervals of a minute until the temperature o the slab falls to about  $5^\circ\text{C}$  below  $\theta_2$ .
- The time temperature graph is drawn and the rate of cooling  $d\theta/dt$  at the steady temperature  $\theta_2$  is determined.

### Young's Modulus - Non uniform bending

- If the beam is loaded at its mid-point, the depression produced will not form an arc of a circle. This type of bending is called non-uniform bending.
- Consider a uniform beam of length  $l$  arranged horizontally on two knife edges and near the ends.

- A weight hanger is suspended and a pin is fixed vertically at mid-point .
- A microscope is focused on the tip of the pin.
- The initial reading on the vertical scale of the microscope is taken. A suitable mass  $W$  is added to the hanger.
- The beam is depressed.
- The cross wire is adjusted to coincide with the tip of the pin.
- The reading of the microscope is noted.
- The depression corresponding to the mass  $M$  is found.
- The experiment is repeated by increasing and decreasing the mass step by step.
- The corresponding readings are tabulated.
- The average value of depression,  $y$  is found from the observations.
- The breadth  $b$ , the thickness  $d$  and length  $l$  of the beam are measured. The value of  $Y$  for the material of the beam is found by the relation.

### Cary foster bridge

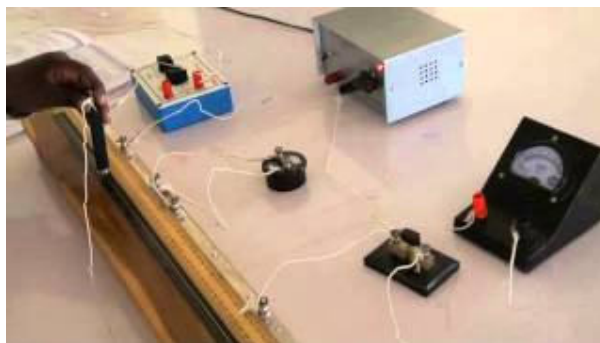

### Procedure

The experiment is performed in two parts.

#### Part I Determination of resistance per unit length, $\rho$ , of the Carey Foster's bridge wire

- Make the circuit connections as shown in above Figure, In this part of the experiment  $Y$  is a copper strip that has negligible resistance and  $X$  is a fractional resistance box. You need to
  - Ensure that the wires and copper strip are clean and the terminals are screwed down tightly,
  - Remove any deposits from the battery terminals and (c) close tightly all of the plugs in the resistance box; these precautions will minimize any contact resistance between the terminals and the connecting wire.
- Plug in the battery key so that a current flows through the bridge. Note that you should remove the battery plug when you are not taking measurements so that the battery does not become drained.
- Press down the jockey so that the knife edge makes contact with the wire, and observe the galvanometer deflection. Release the jockey.

- Move the jockey to different positions along the wire and repeat step 3 at each place until you locate the position of the null point, where there is no deflection of the galvanometer. This point should be near the middle of the bridge wire. Take care that the jockey is pressed down gently to avoid damaging the wire and distorting its cross section, and do not move the jockey while it is in contact with the wire.
- Note the balancing length,  $l_1$ , in your laboratory notebook, using a table with the layout shown in Table 1.
- Reverse the connections to the terminals of the battery and record the balancing length for reverse current in the table in your notebook. By averaging readings with forward and reverse currents, you will be able to eliminate the effect of any thermo Emfs.
- Take out the plug from the fractional resistance box that inserts a resistance of  $0.1 \Omega$ , and repeat steps 3 – 5.
- Increase resistance  $X$  in steps of  $0.1 \Omega$  and repeat steps 3 – 5 each time.
- Interchange the copper strip and fractional resistance box, and repeat steps 3 – 5 for the same set of resistances. The corresponding balancing lengths, measured from the same end of the bridge wire, should be recorded as  $l_2$  in your data table.

### **Part II Determination of an unknown low resistance Y**

- Remove the copper strip and insert the unknown low resistance in one of the outer gaps of the bridge.
  - Repeat the entire sequence of steps as described in the procedure for the first part of the experiment. Record your measurements in your laboratory notebook.
- 
-

**DIAGRAM: Particle Size Determination by Laser**

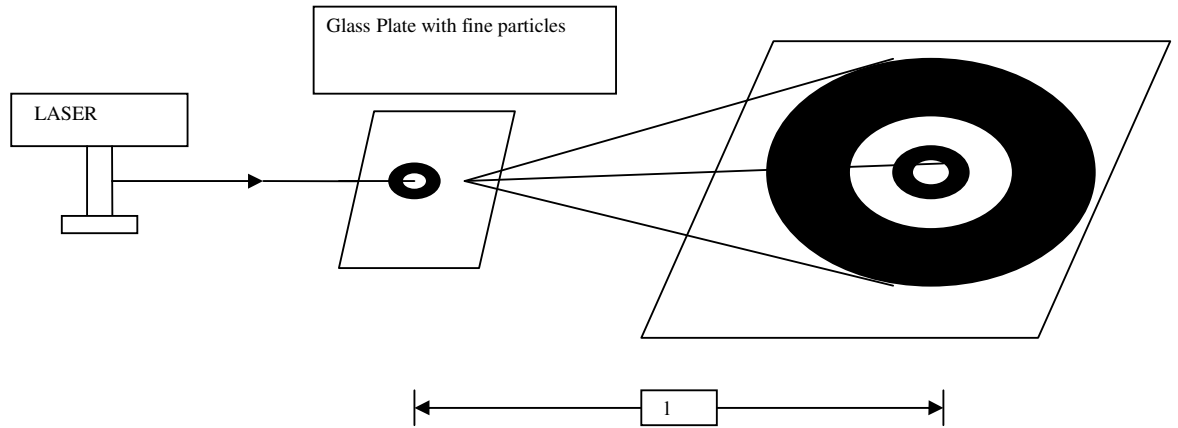

**Determination of size of the micro particle**

Wave length of the laser source  $\lambda = 6900 \times 10^{-10} \text{ m}$

S.No.	Distance between the glass plate and the screen (d)	Distance between the central spot and the n <sup>th</sup> fringe (D <sub>n</sub> )	r <sub>n</sub> = D <sub>n</sub> /2	nd/r <sub>n</sub>	Particle size $D = \frac{1.22\lambda nd}{r_n}$
Unit	$\times 10^{-2} \text{ m}$	$\times 10^{-2} \text{ m}$	$\times 10^{-2} \text{ m}$	$\times 10^{-2} \text{ m}$	$\times 10^{-6} \text{ m}$
<b>Mean =</b>					$\times 10^{-6} \text{ m}$

**EX. NO. :****DATE :****[A] PARTICLE SIZE DETERMINATION BY LASER****AIM:**

To determine the size of the micro particle using laser.

**APPARATUS REQUIRED:**

Laser source, Fine micro particles of nearly uniform size (Lycopodium powder), Glass plate, White screen, Stands, Meter Scale.

**FORMULA:**

$$\text{Size of the micro particle (diameter) } D = \frac{1.22\lambda nd}{r_n} \text{ m}$$

Where

 $n \rightarrow$  Order of diffraction $\lambda \rightarrow$  Wavelength of the laser source 'm' $r_n \rightarrow$  Distance of the  $n^{\text{th}}$  order ring from the central spot of the diffraction pattern 'm'**THEORY:**

When laser is passed through a glass plate spread with fine micro particles, the beam gets diffracted by the particles and circular rings are obtained on the screen. By measuring the radii of the rings and the distance between the glass plate and the screen, the size of the particle can be determined.

**PROCEDURE:**

Sprinkle a thin uniform layer of lycopodium powder on a glass plate. Mount the screen and glass plate upright. The light from laser source transmitted through the layer of lycopodium in the glass plate is adjusted to form a diffracted image in the centre of the screen. Diffracted circular fringes of laser colour will be visible on the screen.

**CALCULATION:**

Size of the micro particle (diameter)  $D = \frac{1.22\lambda nd}{r_n}$  m

After adjusting the distance of the glass plate from the screen so that the first ring radius ( $x_1$ ) and second ring radius ( $x_2$ ) are measured from the central spot. Note the distance ( $l$ ) between screen and plate. Repeat the experiment radius of the first and second rings after adjusting the distance between screen and plate. Calculate the value of the diameter of the particle taking  $\lambda$  value from the previous experiment

**RESULT:**

The average size of the micro particle measured using laser  $D = \dots\dots\dots \times 10^{-6} \text{ m}$

**DIAGRAM: Laser Parameters**

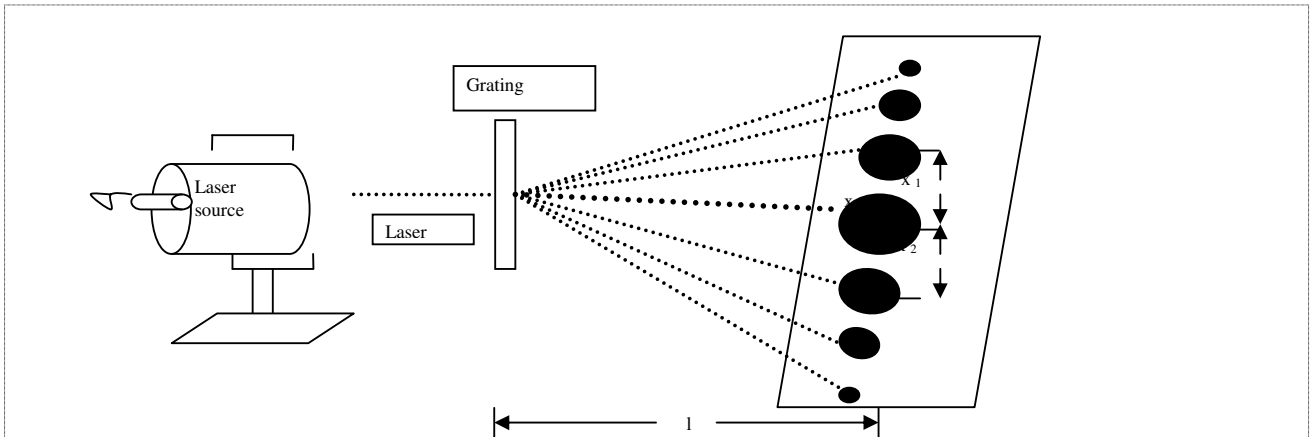

**Determination of wavelength of laser of laser light source**

Number of lines in grating per meter  $N = 6,00,000$  lines /meter,  $m = 1$

S.NO	Distance between the grating and screen (D)	Distance between the order of zero <sup>th</sup> spot and 1 <sup>st</sup> order (X)	$\theta = \tan^{-1} (XD)$	$\lambda = \frac{\sin \theta}{Nm}$
unit	$\times 10^{-2}$ m	$\times 10^{-2}$ m	deg	$\times 10^{-10}$ m
				Mean $\lambda = \dots \dots \dots \times 10^{-10}$ m

**[B] LASER PARAMETERS****AIM:**

To determine the wavelength of the laser of the given laser source of light and angle of divergence using grating.

**APPARATUS REQUIRED:**

Laser source, Laser Grating with stand (2500 lines per inch), Screen, Scale

**FORMULA:**

$$\text{Wave length of the laser source } \lambda = \frac{\sin \theta}{Nn} \text{ m}$$

Where,

**N** → Number of rulings in the grating **Lines/meter**

**n** → Order of spectrum **No unit**

**θ** → Angle of diffraction **Degree**

**THEORY:**

When laser is incident normally on a plane diffraction grating, diffraction takes place. The  $m^{\text{th}}$  order maxima of the wavelength  $\lambda$ , will be formed in a direction  $\theta$  if  $d \sin \theta = n\lambda$  Where  $d$  is the distance between two lines in the grating.

**PROCEDURE****1. To find the number of lines per meter in the grating**

The initial adjustments of the spectrometer are made. The direct ray is coincided with the vertical crosswire and the telescope is fixed. Now the vernier table is released and both the verniers are made to coincide with  $0^\circ$  and  $180^\circ$  and the vernier table is fixed. The telescope is released and moved towards the right side through  $90^\circ$  and fixed. The grating is mounted on the grating table and rotated to the reflected image and coincided with vertical crosswire. Now the vernier table is rotated  $45^\circ$  towards collimator and grating will become perpendicular to the light rays. Telescope is moved to left and right and the perpendicular order ray is coincided and the readings are noted in both the scales.

**CALCULATION**

The wavelength of the given source of light is

$$\lambda = \frac{\sin\theta}{Nm} \text{ m}$$

The number of lines per unit length of the grating can be calculated as follows

$$N = \frac{\sin\theta}{\lambda_m}$$

Where

$\lambda \rightarrow$  is the wavelength of sodium light ( $5893 \times 10^{-10}$  **m**)

The laser source is focused on the screen. The grating is made exactly perpendicular to the light rays. If we use a 1, 00, 00 lines per meter on the grating, nearly 15 orders of diffracted images are formed. The diffracted images can be viewed on the screen. The image has central maxima and several orders in the right and left of the central maxima. The distance( $x_1$ ) of the left side first order dot is measured from the central maxima and is noted down. Similarly the distance ( $x_2$ ) of the first order dot on the right from the central maxima is also measured. All the distances of the dots are measured and noted down in the tabular column.

**RESULT:**

The wavelength of the laser  $\lambda = \dots\dots\dots \times 10^{-10}$  **m**

**DIAGRAM: Numerical aperture and acceptance angle of an optical fibre**

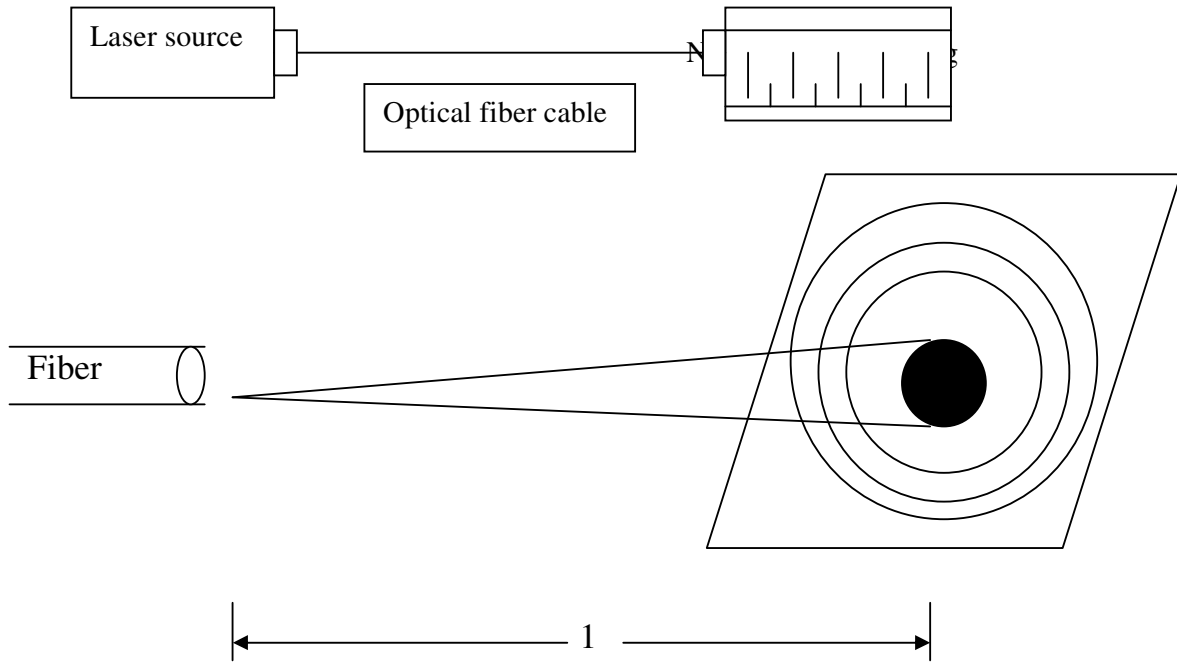

**Determination of numerical aperture and acceptance angle:**

S.No	Diameter of the circle spot (D)	Distance between the fiber end and screen (d)	Radius $r = D/2$	Acceptance angle $\theta_A = r/d$	Numerical aperture $NA = \sin \tan^{-1}(\theta_A)$
Unit	$\times 10^{-2}$ m	$\times 10^{-2}$ m	$\times 10^{-2}$ m	deg	
<b>Mean NA =</b>					

## [C] NUMERICAL APERTURE AND ACCEPTANCE ANGLE OF AN OPTICAL FIBRE

**AIM:**

To determine the numerical aperture and acceptance angle of the given optical fibre.

**APPARATUS REQUIRED:**

Optical fibre cable, Laser source, Numerical aperture jig, White screen with concentric circles, scale

**FORMULA:**

$$\text{Numerical aperture of the optical fibre } NA = \text{Sin } \tan^{-1} \theta_A$$

Where,

$\theta_A \rightarrow$  Acceptance angle of the fibre optic wire.

**THEORY:**

Numerical aperture is a basic parameter of an optical fibre. It is a measure of light gathering power or degree of openness of the fibre. It is the product of the refractive index of the incident medium and the sine of the maximum ray angle.

**PROCEDURE:**

The numerical aperture jig consists of an iron or plastic stand with a moving screen. In this screen, a number of concentric rings of varying diameter are present. In front of it, a stand with a circular slit in the centre is provided which is connected to the laser light source through the optical fiber cable. By moving the screen back and forth the laser light from the circular slit is made to fall exactly on the circles with different diameters. The distance 'l' between the circular slit in the jig and screen for various circular diameters are noted on a moving scale situated at the bottom of the jig. Thus by knowing the values of l and w, the value of the numerical aperture is calculated. The maximum divergent angle (the acceptance angle) is also determined.

**CALCULATION:**

Numerical aperture of the optical fibre  $NA = \sin \tan^{-1}(\theta_A)$

**RESULT:**

1. The numerical aperture of the given optical fiber    **NA = ..... No unit.**
2. The acceptance angle of the given optical fiber     **$\theta_A = \dots\dots\dots$  degree.**

**DIAGRAM : Ultrasonic interferometer**

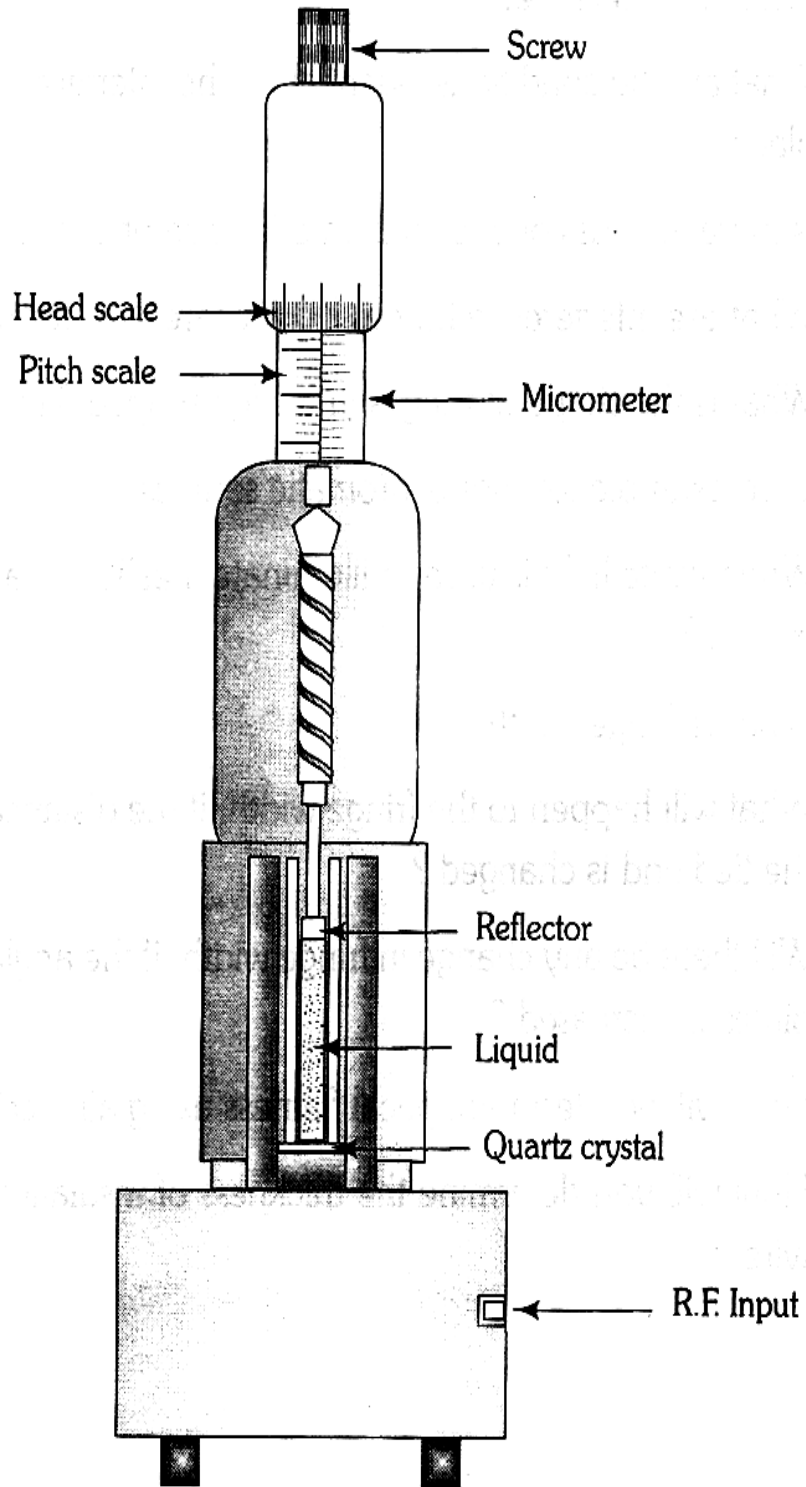

**EX. NO:****DATE :****ULTRASONIC INTERFEROMETER****AIM:**

To determine the velocity of ultrasonic waves in a given liquid and the compressibility of the liquid

**APPARATUS REQUIRED:**

Ultrasonic interferometer (High frequency generator, measuring cell) experimental liquid etc.

**FORMULA:**

$$\text{Velocity of the ultrasonic wave in liquid } V = \frac{2df}{x} \text{ m s}^{-1}$$

Where

**d** → Distance moved by the micrometer **m****f** → Frequency of the ultrasonic wave **Hz****x** → Number of Oscillations

$$\text{Compressibility of the liquid } \beta = \frac{1}{\rho v^2} \text{ m}^2\text{N}^{-1}$$

Where

**ρ** → Density of the given liquid (water = 1000, Benzene = 880) **kg/m<sup>3</sup>****V** → Velocity of the given liquid (**m s<sup>-1</sup>**)**PROCEDURE:**

The measuring cell which is a specially double walled cell for maintaining the temperature of the liquid constant during the experiment is filled up with given liquid. The measuring cell is connected to the output terminal of the high frequency generator through a coaxial cable provided with the instrument. The micrometer screw is initially set as 25 mm. The generator is switched on to excite the quartz crystal at its frequency to generate ultrasonic waves in the liquid.

**Determination of the distance moved by the micrometer screw**

LC = 0.01 mm

TR = PSR + (HSC x LC)

Number of oscillation (x = 1)

S.No	Pitch Scale Reading (PSR)	Head Scale Coincidence (HSC)	HSR=(HSCxLC)	Micrometer Reading (TR) (PSR+HSR)	Difference between two oscillation (d)
Unit	$\times 10^{-3}\text{m}$	div	$\times 10^{-3}\text{m}$	$\times 10^{-3}\text{m}$	$\times 10^{-3}\text{m}$
1.					
2.					
3.					
4.					
5.					
6.					
7.					
8.					
9.					
10.					

Mean (d) = -----  $\times 10^{-3}\text{m}$

This has to be done only after filling the liquid in the measuring cell and not earlier. The generator consists of two knobs namely gain and adjust knobs, which for sensitivity regulation for greater deflection and for initial adjustment of micrometer at zero initially. The adjust knob is adjusted slightly to adjust the position of the needle on the ammeter which is used to notice the number of maximum deflections. The gain knob is rotated and set it to show maximum reading in the ammeter. The micrometer screw is adjusted which is on the top of the measuring cell which can lower or raise the reflector in the liquid in the measuring cell through a known distance, to move downwards

The ammeter readings vary from maximum to minimum and from minimum to maximum value and in between these maxima to minima there occur extra peaks due to a number of reasons, but they do not affect the value of  $\chi/2$ . The rotation of the micrometer screw is continued in the same direction as before. The micrometer reading for the first maximum is noted down and then for successive maxima shown by the interferometer and 20 such readings are recorded. The distance moved by the micrometer screw for x maxima is found and its mean value is found. The velocity of the ultrasonic waves in the liquid medium using the relation  $v = 2df/x$ . The density of the liquid if given is noted, if not given it standard value from the table has to be noted down. Then by substituting all the values in the formula the compressibility of the given liquid can also be found.

**CALCULATION:**

Velocity of the ultrasonic wave in liquid

$$v = \frac{2d f}{x} \text{ ms}^{-1}$$

Compressibility of the liquid

$$\beta = \frac{1}{\rho v^2} \text{ m}^2\text{N}^{-1}$$

**RESULT:**

The velocity of the ultrasonic waves in liquid  $v = \dots\dots\dots\text{ms}^{-1}$

The compressibility of the ultrasonic waves in liquid  $\beta = \dots\dots\dots\text{m}^2\text{N}^{-1}$

DIAGRAM:

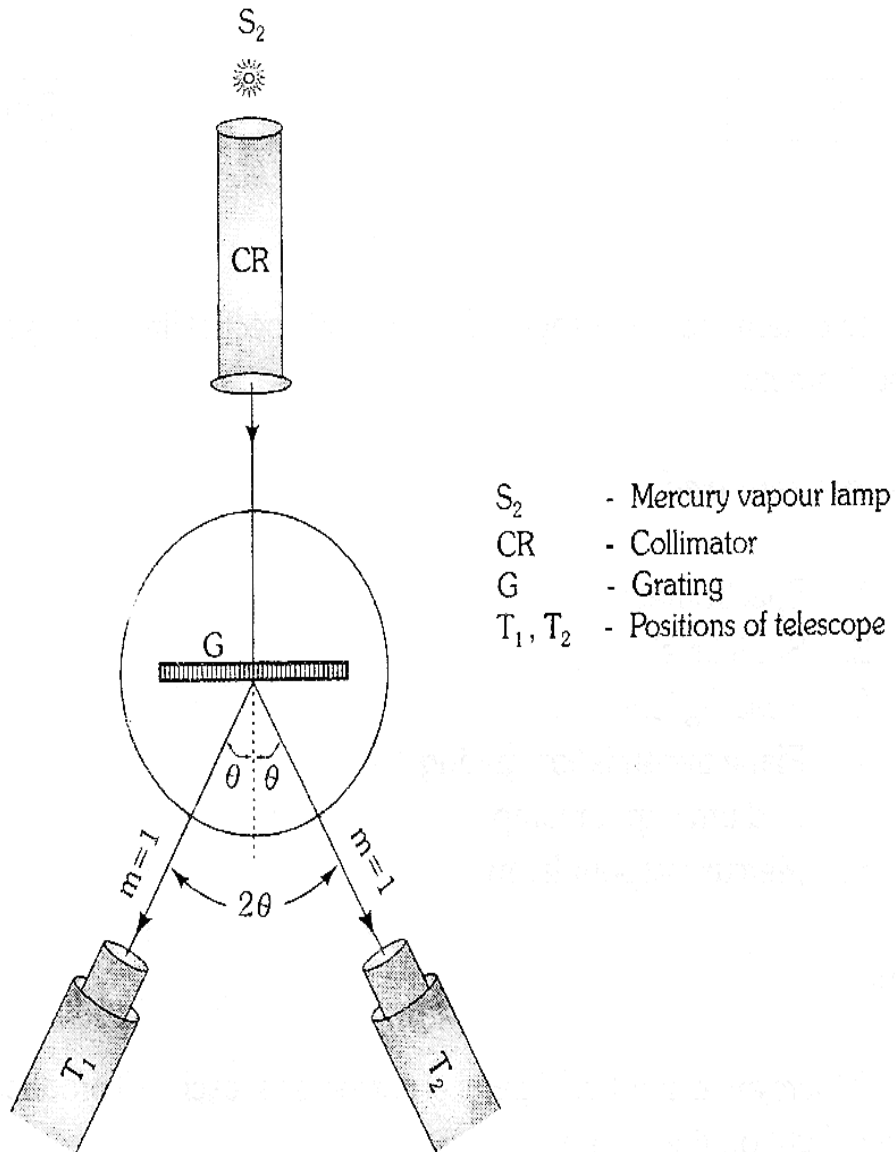

**EX NO:****DATE :****SPECTROMETER – GRATING****AIM:**

To determine the number of lines per metre of the grating and the wavelengths of the prominent lines of the mercury spectrum.

**APPARATUS:**

Spectrometer, grating, sodium and Mercury vapour lamps etc.

**FORMULA:**

$$\text{Number of lines per meter of the grating } N = \frac{\sin \theta}{\lambda m} \text{ Lines/m}$$

Where,

$N$  → Number of lines per metre of the grating

$\theta$  → Angle of diffraction (**degree**)

$M$  → Order of the diffraction (**m=1**)

$\lambda$  → Wavelength of light used

$$\text{Wavelength of the mercury spectrum } \lambda = \frac{\sin \theta}{N m} \text{ \AA}$$

**PROCEDURE:**

**(A) To standardize the grating using sodium light:**

The preliminary adjustments of the spectrometer are made. The slit is illuminated with sodium light. The telescope is brought in a line with the collimator and the direct reading is taken on both the verniers. The prism table is firmly clamped and the telescope is turned

**Determination of number of lines per metre of the grating**

Wavelength of the sodium line  $\lambda = 5893 \times 10^{-10} \text{ m}$

For first order spectrum  $m = 1$ ,  $LC = 1'$

VSR = VSC x LC

TR = MSR + VSR

Reading of the diffracted image												Difference between the readings		Mean $2\theta$	Angle of diffraction $\theta$	$N = \frac{\sin\theta}{\lambda m}$ lines/m
Left						Right						Left	Right			
Ver A1			Ver B1			Ver A2			Ver B2			$2\theta$ A1 ~A2	$2\theta$ B1 ~B2			
MSR	VSR	TR	MSR	VSR	TR	MSR	VSR	TR	MSR	VSR	TR					

**Determination of the wavelength of the spectrum**

Lines of spectrum	Reading of the diffracted image												Difference between the readings		Mean $2\theta$	Angle of diffraction $\theta$	$\lambda = \frac{\sin\theta}{nm}$ lines/m
	Left						Right						Left	Right			
	Ver A1			Ver B1			Ver A2			Ver B2			$2\theta$ A1 ~A2	$2\theta$ B1 ~B2			
	MSR	VSR	TR	MSR	VSR	TR	MSR	VSR	TR	MSR	VSR	TR					

through  $90^\circ$  and fixed in this position (fig-1) The grating is mounted on the table so that the rulings on it are parallel to the slit The grating platform is rotated till the image of the slit reflected from the surface of the grating is seen in the telescope. The platform is fixed in the position at which the vertical crosswire coincides with the fixed edge of the image of the slit. The vernier table is rotated through exactly  $45^\circ$  in the proper direction, so that the surface of the grating becomes normal to the collimator. The prism table is a fixed in this position, now the grating is adjusted for normal incidence

The telescope is now released and brought to the position of the direct image. On either side of it are seen the diffracted images of the first order. The telescope is turned to the left to view the first order diffracted image. The vertical crosswire is made to coincide with the fixed edge of the image of the slit. Readings of both the verniers are taken (fig-2).The telescope is turned to the right.

Reading are noted when the crosswire coincides with the first order image on the right. The difference between the two readings gives  $2\theta$ . Hence  $\theta$  is determined ( $\lambda=5893 \text{ \AA}$ ,  $m=1$ ) The number of lines per metre  $N$  of the grating is calculated using the relation

$$N = \frac{\sin \theta}{\lambda \text{ m}} \text{ Lines / metre}$$

**CALCULATION:**

Number of lines per metre of the grating

$$N = \frac{\sin \theta}{\lambda \text{ m}} \text{ Lines/metre}$$

**(B) Determination of Wavelength of the prominent line of the Mercury spectrum:**

Without disturbing the spectrometer replace the sodium vapour lamp by Mercury vapour lamp whose wavelengths are to be determined. Rotate the telescope and observe the dispersed diffracted spectral lines of Mercury light of first order and second order on either side of central un dispersed direct image are shown in fig. Take reading on both side for the first order diffraction pattern. The angle of diffraction  $\theta$  for the different lines of the first order is measured. The wavelength  $\lambda$  of each line is calculated using the relation

$$\lambda = \frac{\sin \theta}{N m} \mathbf{m}$$

Wavelength of the mercury spectrum

$$\lambda = \frac{\sin \theta}{N m} \text{ \AA}$$

**RESULT:**

The number of lines in the given grating is, N = ..... lines/m

The wavelength of violet-I colour is = ..... Å

The wavelength of violet-II colour is = ..... Å

The wavelength of Blue colour is = ..... Å

The wavelength of Bluish green colour is = ..... Å

The wavelength of Green colour is = ..... Å

The wavelength of Yellow colour is = ..... Å

The wavelength of Red colour is = ..... Å

DIAGRAM:

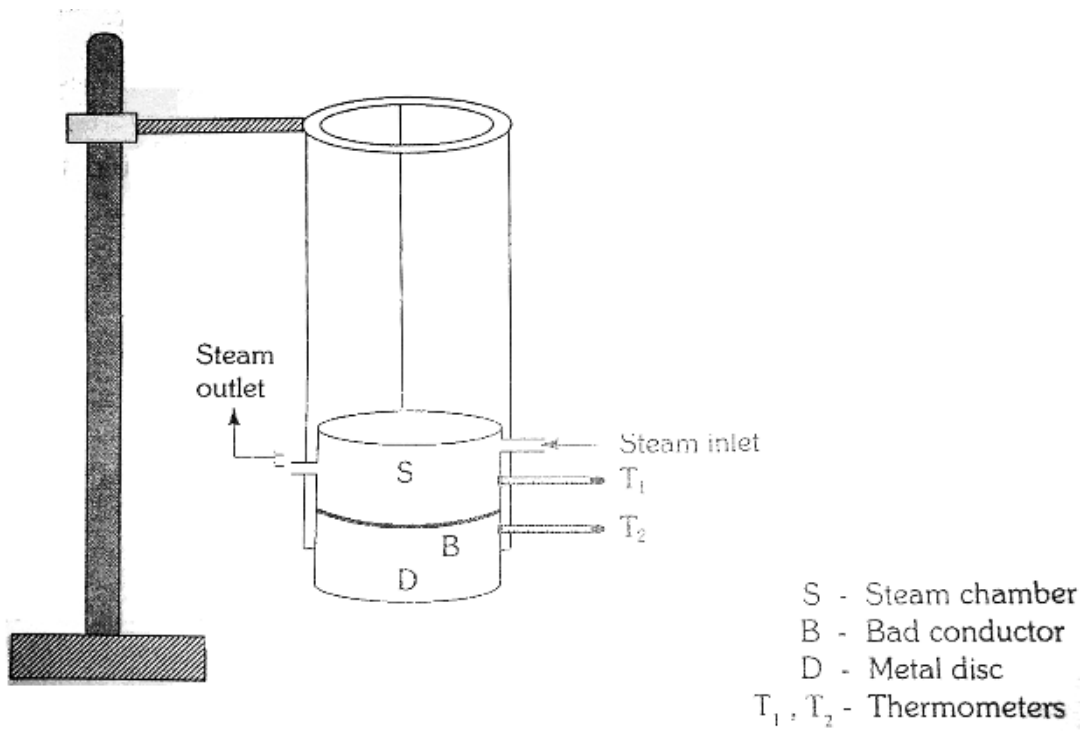

GRAPH:

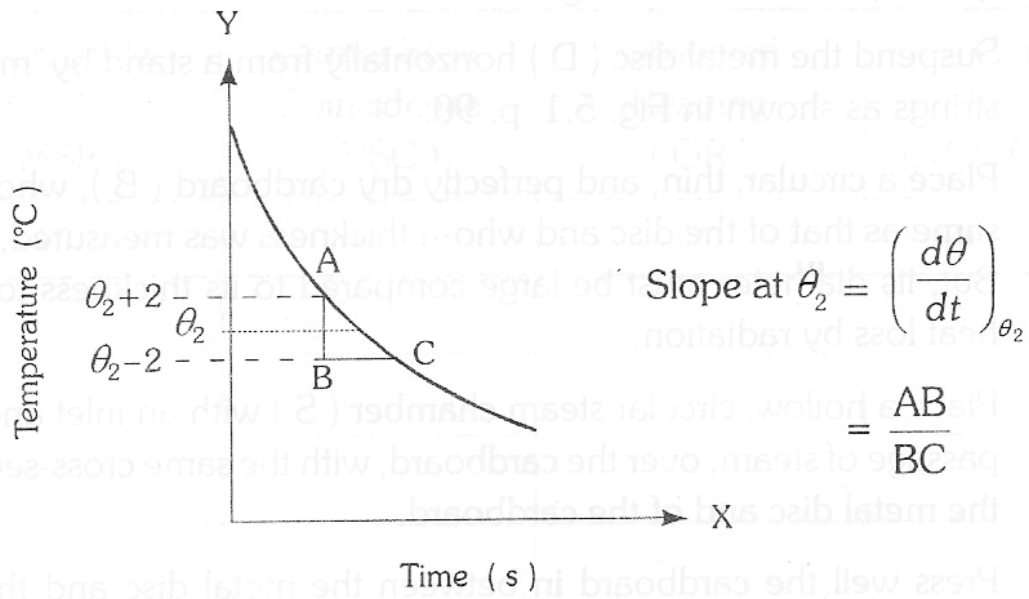

**EX. NO:****DATE :**

## LEE'S DISC –DETERMINATION OF THERMAL CONDUCTIVITY OF A BAD CONDUCTOR

**AIM:**

To determine the coefficient of thermal conductivity of a bad conductor.

**APPARATUS REQUIRED:**

Lee's disc apparatus, bad conductors, stop-clock, thermometers, screw gauge, vernier calipers, steam boiler.

**FORMULA:**

Thermal conductivity of a bad conductor $K = \frac{M S (d\theta/dt)_x (r+2h)}{\pi r^2 (\theta_1 - \theta_2) 2 (r+h)} \text{ Wm}^{-1}\text{k}^{-1}$
--

**Where**

**M** → Mass of the metallic disc (**kg**)

**S** → Specific heat capacity of the material of the disc (**J kg<sup>-1</sup>K<sup>-1</sup>**)

**(dθ/dt)<sub>θ<sub>2</sub></sub>** → rate of cooling at **θ<sub>2</sub> °C**

**r** → Radius of the metallic disc (**m**)

**h** → Thickness of the metallic disc (**m**)

**x** → Thickness of the bad conductor (**m**)

**θ<sub>1</sub>** → steady temperature of a steam chamber (**°C**)

**θ<sub>2</sub>** → steady temperature of the metallic disc (**°C**)

**TABULAR COLUMN**

**To find radius of the metallic disc ® using Vernier Caliper**

**Least count = 0.001cm**

S. No.	MSR $\times 10^{-2}$ m	VSC div	VSR = (VSCXLC) $\times 10^{-2}$ m	Observed reading = MSR + VSR $\times 10^{-2}$ m
1				
2				
3				
4				
5				

Mean (d) = .....  $\times 10^{-2}$  m

Mean (d/2 = r) = .....  $\times 10^{-2}$  m

**To find thickness of the bad conductor (d) using Screw gauge**

**Least count = 0.01mm**

**Zero error = .....div**

**Zero correction = .....mm**

S.No.	PSR $\times 10^{-3}$ m	HSC div	Observed Reading = PSR +(HSCXLC) $\times 10^{-3}$ m	Correct reading = OR $\pm$ ZC $\times 10^{-3}$ m
1				
2				
3				
4				
5				

Mean x = .....  $\times 10^{-3}$  m

## THEORY

The thickness of the bad conductor say card board and thickness of the metallic disc are determined using a screw gauge. The radius of the metallic disc is found using a vernier caliper. The mass of a metallic disc is also found using a common balance. The readings are tabulated.

The whole Lees disc apparatus is suspended from a stand as shown in the figure. The given bad conductor is placed in between the metallic disc and the steam chamber. Two thermometers  $T_1$  and  $T_2$  are inserted into the respective holes. Steam from the steam boiler is passed into the steam chamber until the temperature of the steam chamber and the metallic disc are steady. The Steady temperature ( $\theta_1$ ) of the steam chamber and ( $\theta_2$ ) of the metallic disc recorded by the thermometers are noted.

Now the bad conductor is removed and the steam chamber is placed in direct contact with the metallic disc. The temperature of the disc rapidly rises. when the temperature of the disc rises about  $10^\circ\text{C}$  above  $\theta_2$   $^\circ\text{C}$ , the steam chamber is carefully removed after cutting of the steam supply.

When the temperature of the disc reaches  $10^\circ\text{C}$  above the steady temperature of the disc i.e.  $(\theta_2 + 10)^\circ\text{C}$  stop clock is started. Time for every one degree Celsius fall of temperature is noted until the metallic disc attains a temperature  $(\theta_2 - 10)^\circ\text{C}$ .

A graph is drawn taking time along the x-axis and temperature along the y-axis. The cooling curve is obtained. To obtain the rate of the cooling ( $d\theta/dt$ ). From this graph, a triangle is drawn by taking  $1^\circ\text{C}$  above and  $1^\circ\text{C}$  below the steady temperature  $\theta_2$ . Then the slope  $AB / BC$  gives the rate of cooling at ( $d\theta/dt$ ).

From these readings and using the given formula thermal conductivity of the given bad conductor is calculated.

**To find thickness of the metallic disc (h) using Screw gauge**

Least count = 0.01mm

Zero error = .....div

Zero correction = .....mm

S.No.	PSR mm	HSC div.	Observed Reading = PSR +(HSCXLC) mm	Correct reading = OR ±ZC mm
1				
2				
3				
4				
5				

Mean (h) = ..... x 10<sup>-3</sup> m

**Determine the rate of cooling of metallic disc (dθ/dt)**

S.No.	Temperature (θ) °C	Time (t) Second	S.No.	Temperature (θ) °C	Time (t) Second
1			11		
2			12		
3			13		
4			14		
5			15		
6			16		
7			17		
8			18		
9			19		
10			20		

**CALCULATION**

Thermal conductivity of a bad conductor  $\mathbf{K} = \frac{\mathbf{M S (d\theta/dt) x (r + 2h)}}{\mathbf{\Pi r^2 (\theta_1 - \theta_2) 2 (r + h)}} \mathbf{Wm^{-1}k^{-1}}$

**RESULT:-**

Thermal conductivity of the given bad conductor = -----  $\mathbf{Wm^{-1}K^{-1}}$

**DIAGRAM:**

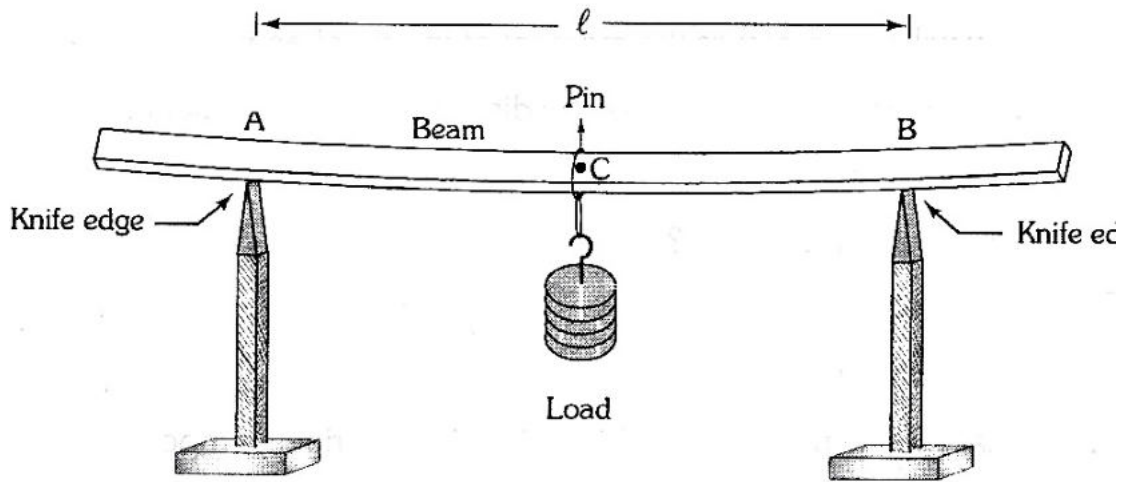

Young's modulus by non-uniform bending

**To find the depression (y)**

**LC = 0.001 cm**

**TR = MSR + (VSC × LC)**

S.N	Load $\times 10^{-3}$ kg	Traveling Microscope Reading						Mean cm	Depression 'y' for M $\text{kg} \times 10^{-2}$ m
		Increasing load			Decreasing load				
		MSR cm	VSC div	TR cm	MSR cm	VSC div	TR cm		
1	W								
2	W+50								
3	W+100								
4	W+150								
5	W+200								
Mean (y) =									

**EX. NO:****DATE :****YOUNG'S MODULUS-NON-UNIFORM BENDING****AIM:**

To determine the young's modulus of the material of a beam supported on two knife edges and loaded at the middle point.

**APPARATUS REQUIRED:**

A uniform rectangular beam, two equal knife edges, a weight hanger with slotted weight, vernier microscope, pin, screw gauge, vernier caliper.

**FORMULA:**

<p><b>The Young's modulus of the material</b></p> $E = \frac{m g l^3}{4 b d^3 y} \text{ Nm}^{-2}$
---

Where,

- E → Young's modulus of the material of the beam -  $\text{Nm}^{-2}$   
 m → the load producing the depression - **Kg**  
 g → acceleration due to gravity -  $\text{ms}^{-2}$   
 l → Length of the beam between the two knife edges - **m**  
 b → breadth of the beam - **m**  
 d → thickness of the beam - **m**  
 y → the depression produced for a load - **m**

**To find the breadth of the beam using vernier caliper**

$$LC = 0.001\text{cm}$$

$$OR = MSR + (VSC \times LC)$$

S.No.	MSR $\times 10^{-2}$ m	VSC div	VSR =(VSCXLC) $\times 10^{-2}$ m	OR =MSR + VSR $\times 10^{-2}$ m
1				
2				
3				
4				
5				
Mean (b)				$\times 10^{-2}$ m

**To find the thickness of the beam using Screw gauge**

$$LC = 0.01 \text{ mm}$$

$$ZE = \pm \text{----- div}$$

$$ZC = \pm (ZE \times LC) = \text{-----} \times 10^{-3}\text{m}$$

S.No	Pitch scale reading (PSR) $\times 10^{-3}$ m	Head scale Reading(HSC) div	Observed reading = PSR+(HSC x LC) $\times 10^{-3}$ m	Correct reading = OR $\pm$ ZC $\times 10^{-3}$ m
1				
2				
3				
4				
5				
				d = $\times 10^{-3}$ m

## PROCEDURE

The given beam is symmetrically supported on two knife edges. A weight hanger is supported by means of a loop of thread from the point C, exactly midway between the knife edges. A pin is fixed vertically at C by some wax. The length of the beam ( $l$ ) between the knife edges is set for 60 cm. A traveling microscope is focused on the tip of the pin such that the horizontal cross wire coincides with the tip of the pin.

The reading in the vertical traverse scale is noted for dead load. In equal steps of  $m$  Kg added to the weight hanger, the corresponding readings for loading are noted. Similarly readings are noted while unloading. The breadth and the thickness of the beam are measured with a vernier calipers and screw gauge respectively. From the data Young's modulus of the beam is calculated.

**CALCULATION:**

Load applied at mid point  $m = \text{-----} \times 10^{-3} \text{ kg.}$   
Acceleration due to gravity  $g = \text{-----} \text{ ms}^{-2}$   
Breadth of the beam  $b = \text{-----} \times 10^{-2} \text{ m}$   
Thickness of the beam  $d = \text{-----} \times 10^{-3} \text{ m}$   
Length of the beam between the knife edges  $l = \text{-----} \times 10^{-2} \text{ m}$

**RESULT:**

Young's modulus of the material of the given beam  $E = \text{----- Nm}^{-2}$

**CIRCUIT DIAGRAM**

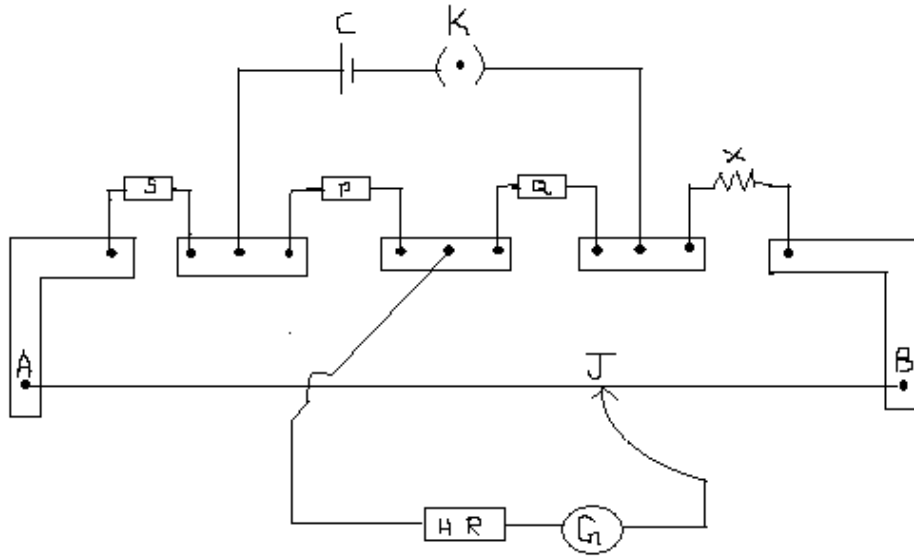

**FIG. CAREY-FOSTER'S BRIDGE**

To find the radius of the given coil of wire.

LC = 0.01 mm

ZE = ± ..... div  
 ZC = ± (ZE x LC) = ..... x 10<sup>-3</sup>m

S.No	Pitch scale reading (PSR) x 10 <sup>-3</sup> m	Head scale reading (HSC) div	Observed reading = PSR+ (HSC x LC) x 10 <sup>-3</sup> m	Correct reading = OR ± ZC x 10 <sup>-3</sup> m
1				
2				
3				
4				
5				
				Mean (d) = ..... radius d/2 = (r) ..... x 10 <sup>-3</sup> m

**EX. NO:**  
**DATE :**

## 6. CAREY-FOSTER'S BRIDGE

### AIM

To determine the specific resistance of the material of the given wire.

### APPARATUS REQUIRED

Carey foster bridge, coil of the given wire, Lechlanche cell (Bt), Key, Two equal resistances P & Q, Galvanometer, high resistance, Jockey, Known resistance box (R)

### FORMULA

$$\text{Resistance of the given coil of wire } X = R + (l_1 - l_2) r_b \text{ (}\Omega\text{)}$$

$$\text{Specific resistance of the given coil of wire } \rho = \frac{X \pi r^2}{\ell} \text{ (}\Omega / \text{m )}$$

Where,

- |            |   |  |
|------------|---|--|
| $r_b$      | → | resistance per metre length of the bridge wire ohm/metre ( $\Omega / \text{m}$ ) |
| $X$        | → | unknown resistance –ohm ( $\Omega$ )   |
| $l_1, l_2$ | → | Balancing lengths – metre ( $\text{m}$ )   |
| $R$        | → | Known value of resistance in the resistance box –ohm ( $\Omega$ )                |
| $r$        | → | Radius of the given coil of wire –metre ( $\text{m}$ )                           |
| $l$        | → | Length of the given coil of wire – metre ( $\text{m}$ )                          |

**Determination of unknown resistance (B)**

S.No.	Resistance introduced in the box R Ohm ( $\Omega$ )	Balancing length AJ(cm)		B = R / ( $l_2 - l_1$ ) Ohm ( $\Omega$ )
		With R in the left gap ( $l_1$ ) $\times 10^{-2}$ m	With R in the right gap ( $l_2$ ) $\times 10^{-2}$ m	
1.				
2.				
3.				
4.				
5.				
6				
7				
8				
9				
10				
<b>Mean (B) =</b>				

## PROCEDURE

### To find the unknown resistance(X) and specific resistance ( $\rho$ ).

The primary and the secondary circuits are connected as shown in the figure. The equal resistances P and Q are included in the two inner gaps. Resistance box R is included in the left gap 3 and unknown resistance X is included in the right gap. Known value of resistances R are included (say 0.2,0.3 ohms etc.,) and the balancing length ( $AJ = l_1$ ) is measured in each case and tabulated.

The position of R and X is interchanged. The experiment is repeated for the same values of R (say 0.2,0.3 ohms etc.,) and the balancing length ( $AJ = l_2$ ) is measured and tabulated. In order to determine the resistance ( $r_b$ ) per metre length of the bridge wire, a thick copper strip of zero resistance is placed in the left gap (3) and standard resistance of 0.1 ohms is placed at right gap (4) and balancing length ( $AJ = l_a$ ) is noted and tabulated. Now by placing the copper strip at the right gap (4) and 0.1 ohms at the left gap (3), the balancing length ( $BJ = l_b$ ) is noted and tabulated.

Substituting the values of  $l_a$  and  $l_b$  in the given formula, the value of  $r_b$  is calculated. By substituting this value in the given formula, the unknown resistance (X) of the given coil of wire is calculated. Specific resistance the radius of the given coil of wire ( $r$ ) is found using screw gauge and the length of the wire ( $l$ ) is measured. By substituting the value for X,  $r$  and  $l$  in the given formula, the specific resistance of the given coil of wire can be determined.

**Determination of unknown resistance (B)**

S. No.	Resistance introduced in the box R Ohm ( $\Omega$ )	Balancing length AJ(cm)		$X = R + (l_1 - l_2) B$ Ohm ( $\Omega$ )
		With R in the left gap ( $l_1$ ) $\times 10^{-2}m$	With R in the right gap ( $l_2$ ) $\times 10^{-2}m$	
1				
2				
3				
4				
5				
6				
7				
8				
9				
10				
<b>Mean (X) =</b>				

**CALCULATION**

Radius of the given coil of wire  $r = \text{----- metre (m)}$

Length of the given coil of wire  $l = \text{----- metre (m)}$

Specific resistance of the given coil of wire  $\rho = \frac{X \pi r^2}{\ell}$  ohm-metre ( $\Omega \text{ m}$ )

$\rho = \text{-----Ohm-m (}\Omega \text{ m)}$

**RESULT**

The unknown resistance of the given coil of wire (**X**) =----- **ohms**

Specific resistance of the given coil of wire       **$\rho$**  = ----- **ohm-meter.**