

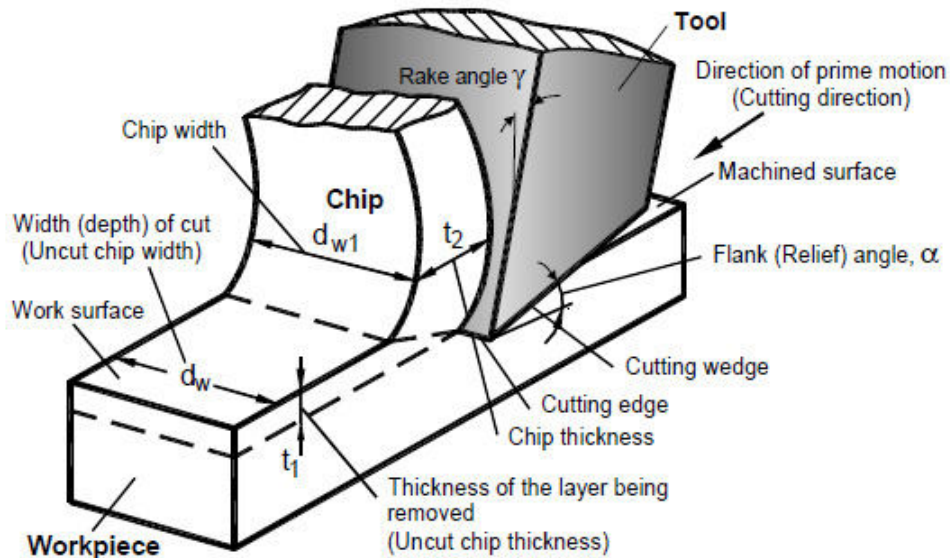

# **VARUVAN VADIVELAN** **INSTITUTE OF TECHNOLOGY**

DHARMAPURI – 636 703



## **LAB MANUAL**

ME 6311 - MANUFACTURING TECHNOLOGY  
LABORATORY-I

REGULATION

2013

BRANCH

MECHANICAL ENGINEERING

YEAR / SEM

II YEAR & III SEMESTER

**ANNA UNIVERSITY::CHENNAI 600025**

**REGULATION-2013**

**ME6311-MANUFACTURING TECHNOLOGY LABORATORY-I**

**OBJECTIVES**

- To study and practice the various operations that can be performed in lathe, shaper, drilling, milling machines etc. and to equip with the practical knowledge required in the core industries.

**LIST OF EXPERIMENTS**

Machining and Machining time estimations for:

1. Taper Turning
2. External Thread Cutting
3. Internal Thread Cutting
4. Eccentric Turning
5. Knurling
6. Square Head Shaping
7. Hexagonal Head Shaping

**OUTCOMES**

- Upon completion of this course, the students can able to demonstrate and fabricate different types of components using the machine tools.

**INDEX**

| <b>EX. NO.</b> | <b>DATE</b> | <b>NAME OF THE EXPERIMENT</b>                             | <b>SIGNATURE</b> | <b>REMARKS</b> |
|----------------|-------------|---|------------------|----------------|
| <b>1</b>       |             | STUDY ON BASIC MACHINING                                  |                  |                |
| <b>2</b>       |             | STUDY OF SHAPER   |                  |                |
| <b>3</b>       |             | STUDY OF MILLING MACHINE                                  |                  |                |
| <b>4</b>       |             | TAPER TURNING OPERATION BY USING A LATHE                  |                  |                |
| <b>5</b>       |             | EXTERNAL THREAD CUTTING BY USING A LATHE                  |                  |                |
| <b>6</b>       |             | KNURLING OPERATION BY USING A LATHE                       |                  |                |
| <b>7</b>       |             | INTERNAL THREAD CUTTING BY USING A LATHE                  |                  |                |
| <b>8</b>       |             | ECCENTRIC TURNING OPERATION BY USING A LATHE              |                  |                |
| <b>9</b>       |             | MACHINING HEXAGON FROM ROUND ROD BY USING MILLING MACHINE |                  |                |
| <b>10</b>      |             | MACHINING SQUARE FROM ROUND ROD BY USING SHAPER           |                  |                |

**GENERAL INSTRUCTIONS**

1. All the students are instructed to dress appropriately. Remove any necklaces or other dangling jewelry, wristwatch or rings. Secure any loose-fitting clothing and roll up long sleeves. Wear an apron or a properly fitted shop coat. Safety glasses are a must.
2. Do not attempt to operate a machine until you know the proper procedures and have been checked out on its safe operation by your instructor.
3. Keep the machine clear of tools and always stop the machine before making measurements and adjustments.
4. Don't operate any machine without getting concerned staff member's prior permission.
5. All the students are advised to come with completed record and corrected observation book of previous experiment.
6. Extreme care must be taken to avoid any possible injury while on laboratory work. In case, anything occurs immediately report to the staff members.

**EX.NO:1**

**DATE :**

**STUDY ON BASIC MACHINING**

**AIM**

To study the construction details and working principle of basic machining.

**INTRODUCTION**

Machining is the process of converting the given work piece into the required shape and size with help of a machine tool. The most widely used machine tool is lathe. In simple words machining is the process of removing certain material from the work piece.

**LATHE**

Lathe is the machine tool which is used to perform several operations on the work piece. Lathe is useful in making several parts which is further assembled to make new machine. Hence lathe is known as “mother of machines”.

**BASIC WORKING PRINCIPLE OF LATHE**

In lathe, the work piece is held in the chuck, a work holding device. The cutting tool is mounted in the tool post. The chuck is rotated by means of power. When the chuck rotates, the work piece also rotates. The tool is moved against the rotating work piece by giving small amount of depth of cut. The material is removed in the form of chips. Continuous feed and depth of cut is given until the required dimensions are obtained in the work piece.

**TYPES OF LATHE MACHINES**

There are different types of lathe machines, they are

1. Centre lathe
2. Tool room lathe
3. Bench lathe
4. Capstan lathe
5. Turret lathe
6. Automatic lathe

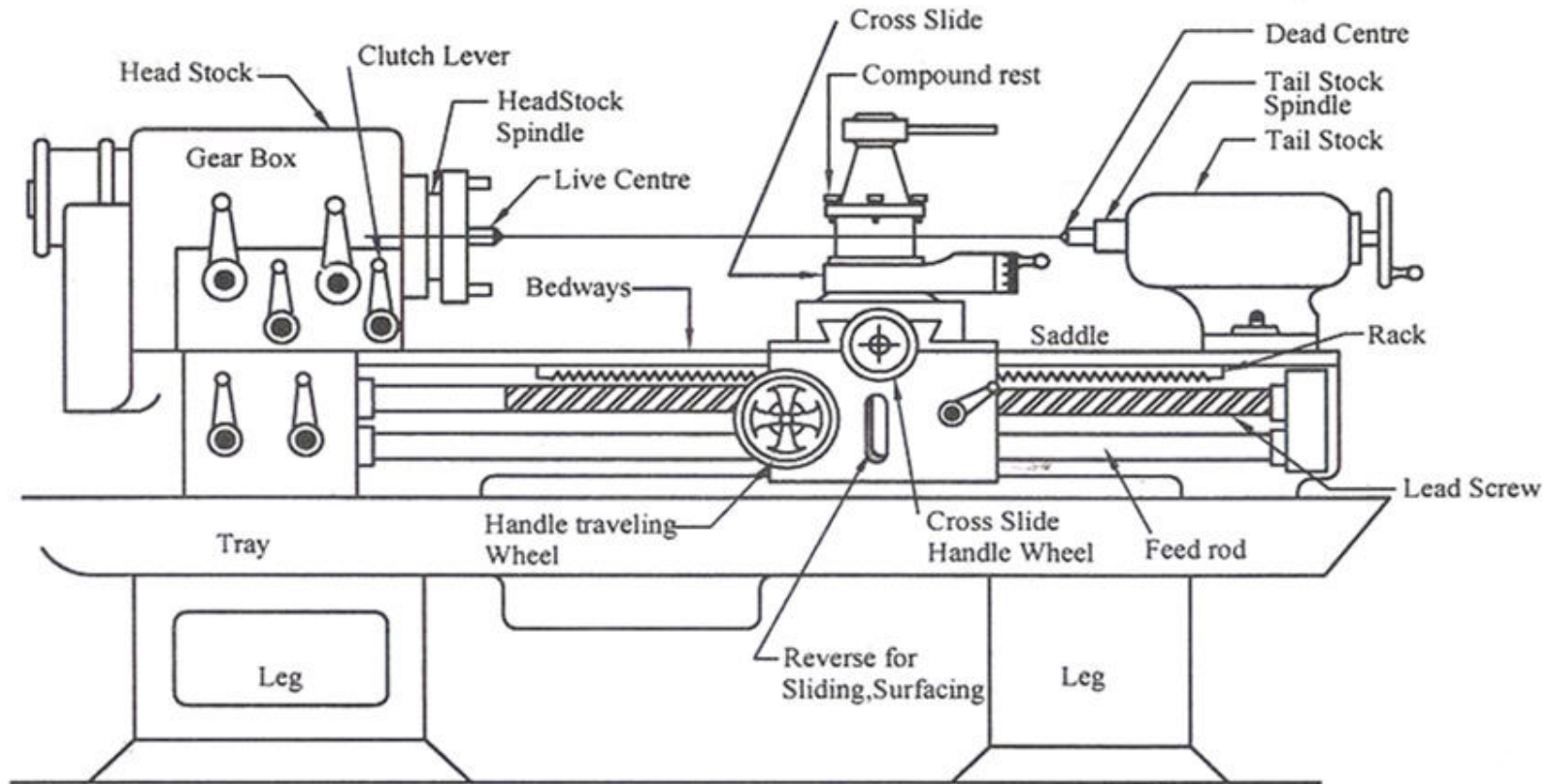

Fig. 1 The centre Lathe

## DESCRIPTION OF LATHE

Lathe is a machine which has several parts in it. They are

### **1. Bed**

It is the base of the machine. On its left side, the head stock is mounted and on its right it has movable casting known as tailstock. Its legs have holes to bolt down on the ground.

### **2. Head stock**

It consists of spindles, gears and speed changing levers. It is used to transmit the motion to the job. It has two types one is the headstock driven by belt and the other one is the gear driven.

### **3. Carriage**

Carriage is used to carry a tool to bring in contact with the rotating work piece or to withdraw from such a contact. It operates on bed ways between the headstock and tail stock.

### **4. Saddle**

It is an 'H' shaped part fitted on the lathe bed. There is a hand wheel to move it on the bed way. Cross slide, compound rest, tool post is fitted on this saddle.

#### a) Cross slide

It is on the upper slide of saddle in the form of dove tail. A hand wheel is provided to drive the cross slide. It permits the cross wise movement of the tool (i.e.) movement of tool towards or away from the operator

#### b) Compound rest

It is fitted over the cross slide on a turn table. It permits both parallel and angular movements to cutting tool.

#### c) Tool post

It is fitted on the top most part of the compound rest. Tool is mounted on this tool post. Cutting tool is fixed in it with the help of screws.

### **5. Apron**

It is the hanging part in front of the carriage. It accommodates the mechanism of hand and power feed to the cutting tool for carrying out different operations.

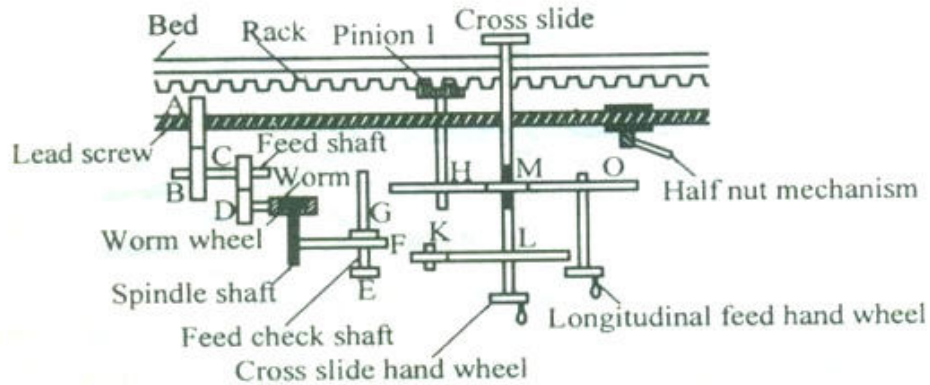

Fig. 2 Apron

### 6. Lead screw

It is a long screw with ACME threads. It is used for transmitting power for automatic feed or feed for thread cutting operation.

### 7. Tail stock

It is located at the right end of the lathe bed and it can be positioned anywhere in the bed. It is used for supporting lengthy jobs and also carries tool to carry out operations such as tapping, drilling, reaming.

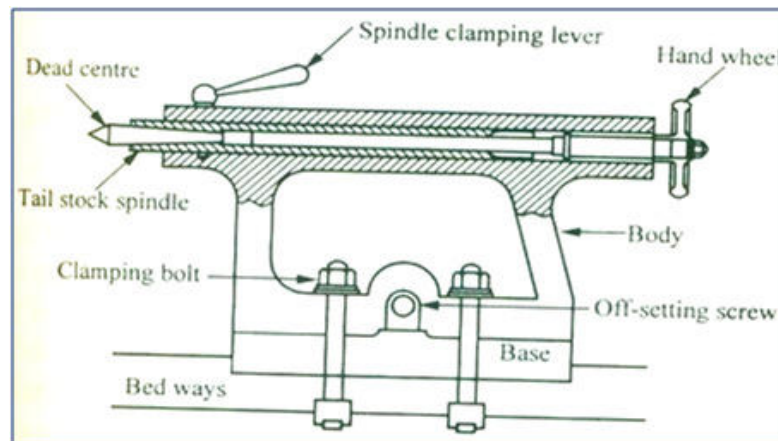

Fig. 3 Tailstock

## WORK HOLDING DEVICES

### 1. Lathe centers

They are used to support work. It has two categories of centers. Live center is one which is fitted in the headstock spindle. Dead is another one which is fitted in the tail stock.

2. Chuck

It is a device used to hold a job. It is easily fitted on the thread cut on the end of head stock spindle. Various types of chuck are

- a) Two jaw chuck
- b) three jaw chuck
- c) four jaw chuck
- d) collet chuck
- e) Magnetic chuck

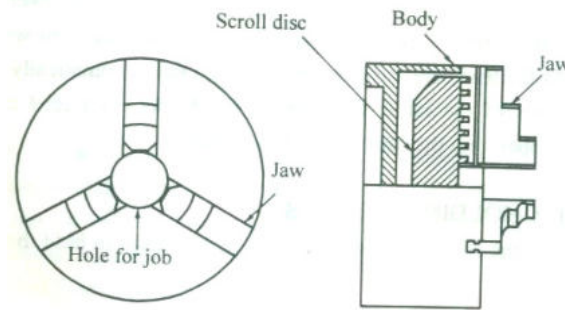

Fig. 4 Three Jaw Universal self-centering chuck

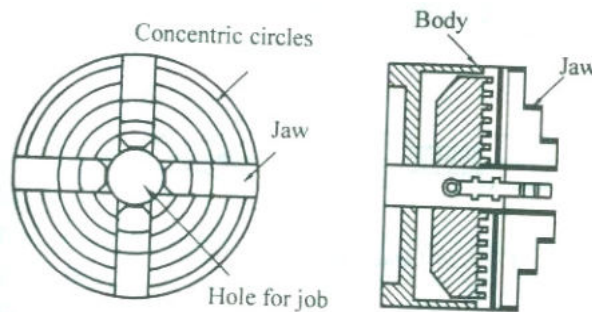

Fig. 5 Four Jaw Independent chuck

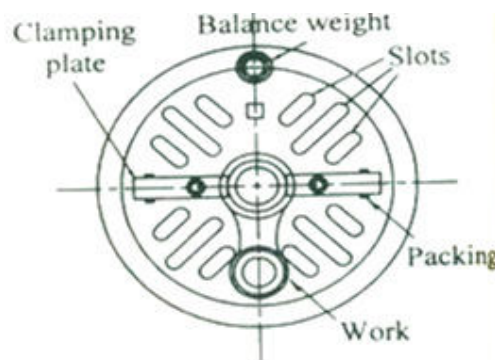

Fig. 6 Face Plate

3. Face plate
4. Catch plate
5. Lathe carriers or dog's
6. Steady rest
7. Mandrel
8. Follower rest

### CUTTING TOOLS USED

For making a finished job on lathe machine, various types of cutting tools are used. One of them is single point cutting tool which is used to perform several operations on the work piece. Various types of cutting tools are

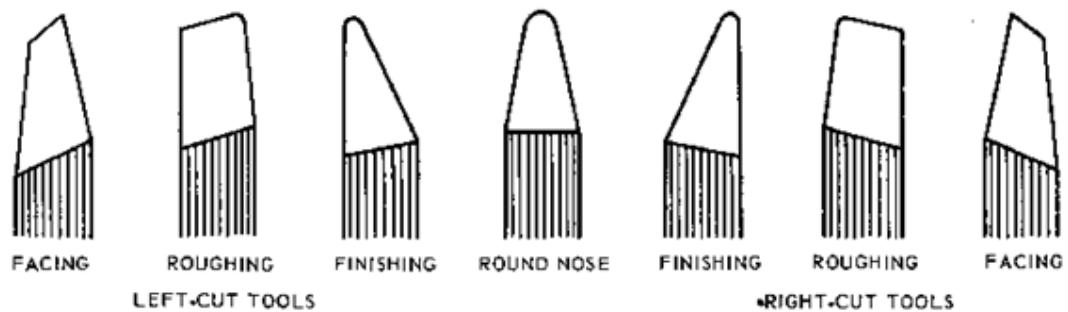

Fig. 7 Cutting Tools

#### **1. Facing Tool**

It is used for facing the longitudinal ends of the job. Its shape is like a knife.

#### **2. Rough Turning Tool**

It is used to remove excess material from the work piece in quick time. It can be used to give large depth of cut and work at coarse feed.

#### **3. Finishing Tool**

It is used for getting smooth finish on the work piece. Its point is a little more round.

#### **4. Radius Tool**

Jobs which need round cutting are done with this tool. Its type is

- a) Convex radius tool
- b) concave radius tool

### 5. Parting Tools

It is used to cut the jobs into two parts. It is also used for grooving.

### 6. Form Turning Tool

It is used for jobs which require both convex and concave turning.

### 7. Thread Cutting Tool

It is used for making internal or external threads on the work piece. The tool nose is designed with a definite profile for taking threads.

### 8. Drill Tool

It is used for making holes of various diameters on the job. Drill bit of various sizes of diameter are available.

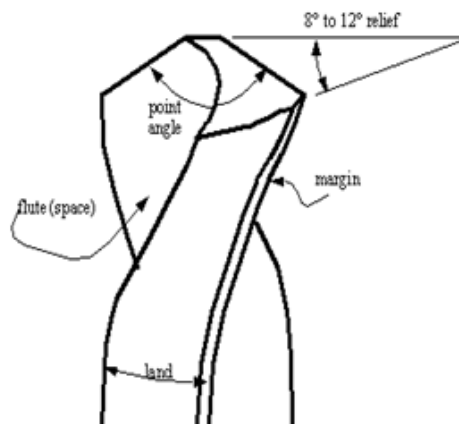

Fig. 8 Drill Tool

### 9. Boring Tool

It used for enlarging the drill hole.

### 10. Knurling Tool

Drawing slanting or square projecting lines on the surface of a job is known as knurling. It is used for making better grip on the surface of a job.

## TOOL MATERIALS

1. The single point cutting tools are made of high speed steel. (H. S. S)
2. The main alloying elements in 18 – 4 – 1 HSS tools are 18 % tungsten, 4% chromium and 1 % Vanadium. 5 to 10 % cobalt is also added to improve the heat resisting properties of the tool.
3. General purpose hand cutting tools are usually made from carbon steel or tool steel.
4. Carbide tipped tools fixed in tool holders, are mostly used in production shops.

**NOMENCLATURE OF SINGLE POINT CUTTING TOOL**

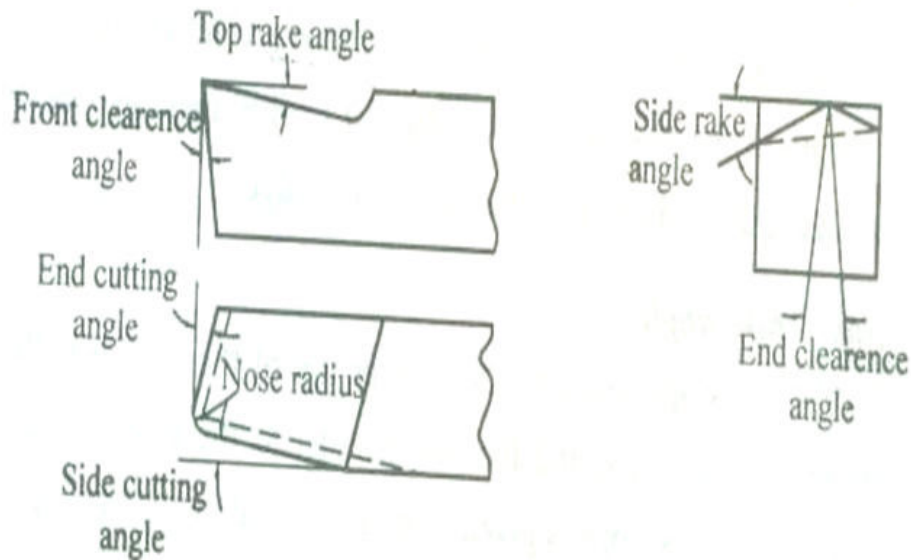

Fig. 9 Nomenclature of Single Point Cutting Tool

**CUTTING TOOL ANGLES**

- 1) Top rake angle (back rake angle)
  - a. If the slope is given to the face or surface of the tool and if this slope is along the tools length then it is called top rake angle. It is usually  $15^{\circ}$  to  $20^{\circ}$ .
- 2) Side rake angle
  - a. If the slope is given to the face or top of the tool along the tools width then it is called side rake angle. It lies between  $6^{\circ}$  and  $15^{\circ}$ .
- 3) Clearance angle (relief angle)
  - a. Types:
    1. Side clearance angle
    2. End clearance angle.
  - b. They are provided to keep surface of the tool clear of the work piece.
- 4) Cutting edge angle (Types)
  1. Side cutting edge angle – (generally  $15^{\circ}$ ) it is an angle, the side cutting edge makes with the axis of the tool.
  2. End cutting edge angle – (from  $7^{\circ}$  to  $15^{\circ}$ ) it is an angle, the end cutting edge makes with the width of the tool.

- 5) Lip angle (cutting angle)
  - a. It is the angle between the face and the end surface of the tool.
- 6) Nose angle
  - b. It is the angle between the side cutting edge and end cutting edge.

### LATHE OPERATIONS

1. Facing
  - It is done for getting fine finish (good surface finish) on the face of the job.
  - Facing tool is set at an angle to the work piece.
  - The tool is fed from the centre of work piece towards the outer surface against the rotating work piece.
  - Depth of cut is low for the facing operation.

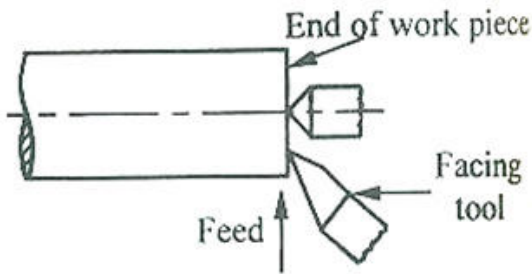

Fig. 10 Facing

2. Plain Turning
  - It is done for reducing the diameter of the work piece.
  - A cutting tool with  $70^\circ$  setting angle is used for roughing operation.
  - More feed is given for rough turning while less feed is given for finishing.
  - Work piece is held in chuck and tool is set to center height of the work piece.

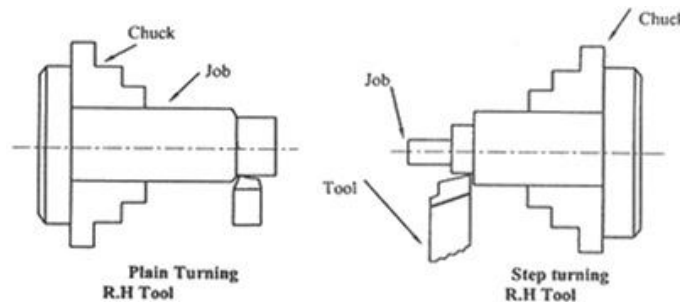

Fig. 11 Plain Turning

### 3. Step Turning

- It is similar to the process of turning but in this case different diameter in step of various sizes is taken on the work piece.

### 4. Taper Turning

- It is different from the turning operation.
- Taper is defined as uniform change in the diameter of a work piece measured along its length.

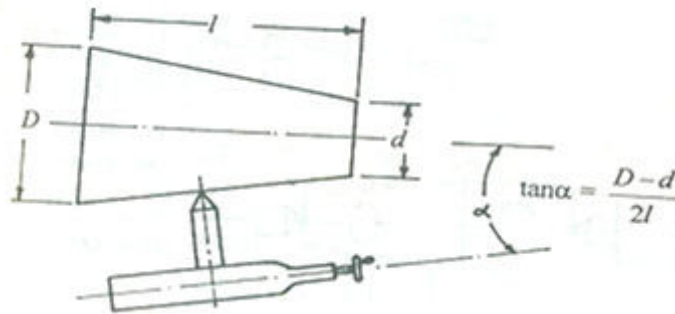

Fig. 12 Taper Turning

The angle is determined by using the formula  $\tan \alpha = \frac{D-d}{2l}$

Where,       $D$       –      large Diameter  
                  $d$       –      Small diameter  
                  $l$       –      Length of taper

### 5. Knurling

- It is process of making serrations on the work piece.
- Knurling tools of different shape and size are used to make grip on the work piece. It has two hardened steel rollers.
- The tool is held in tool post and pressed against the rotating work piece.
- Work piece is rotated at lower speed and small amount of feed is given.

### 6. Drilling

- It is a process of making a hole on the work piece
- Job is held in chuck while the drill is held in the tail stock sleeve.

- Feed is given by rotating the hand wheel in the tail stock which pushes the tailstock sleeve.

### **CUTTING SPEED**

- It is the peripheral speed of the work past the cutting tool.
- It is the speed at which metal is removed by the tool from the work piece.
- It is expressed in meter / minute.

$$\begin{aligned}\text{Cutting speed} &= \frac{\pi \times \text{diameter} \times \text{R.P.M}}{1000} \\ &= \frac{\pi DN}{1000} \text{ in } m/\text{min}\end{aligned}$$

Where, D – Diameter in mm

N – Spindle speed in rpm

### **FEED**

- It is defined as the rate of tool travel across a surface cutting it.
- It is the distance of the tool advances for each revolution of the work piece.
- It is expressed in mm/revolution.

### **DEPTH OF CUT**

- It is the perpendicular distance measured from the machined surface to the uncut surface of work. It is expressed in mm.

$$\text{depth of cut} = \frac{d_1 - d_2}{2}$$

Where,  $d_1$  = diameter of work before machining

$d_2$  = diameter of work after machining.

### **RESULT**

Thus the basic machining was studied.

**EX.NO:2**

**DATE :**

**STUDY OF SHAPER**

**AIM**

To study the construction details and working principle of a shaper machine tool.

**CONSTRUCTION AND WORKING PRINCIPLE**

- Shaper is a reciprocating type of machine tool. It is used for machining the surfaces. The surface may be horizontal and vertical indeed. The shaper has the main parts such as base, table, column, cross-rail, ram and tool head. The base bolted to the floor, it is made of C.I and absorbs entire load.
- The column is box type in which return mechanism of ram is provided. At the top of the column, there are two mechanical I guide ways. The ram reciprocating on their guide ways in the front vertical guide ways in which the table the rectangular hollow block. It slides rail is mounted guide ways of iron-rail. It has machine surface on the top and slides. These surfaces have T slots for clamping work. The rail carries the tool head in which the tool head is in vertical position. The ram reciprocation on the guide ways on top of column.
- The work is held on the table by using correct work holding device. A single tool is in vertical position of the cutting stroke (forward bias) the feed is given at the end of each cutting stroke during the return stroke, no metal is cut. The cutting stroke takes place at slow speed and the return stroke takes place at a faster speed. The faster feed rate is obtained using quick return.
- By adjusting the work piece position as tool position step cutting, v-cutting, etc....., is machined in shaping machine.

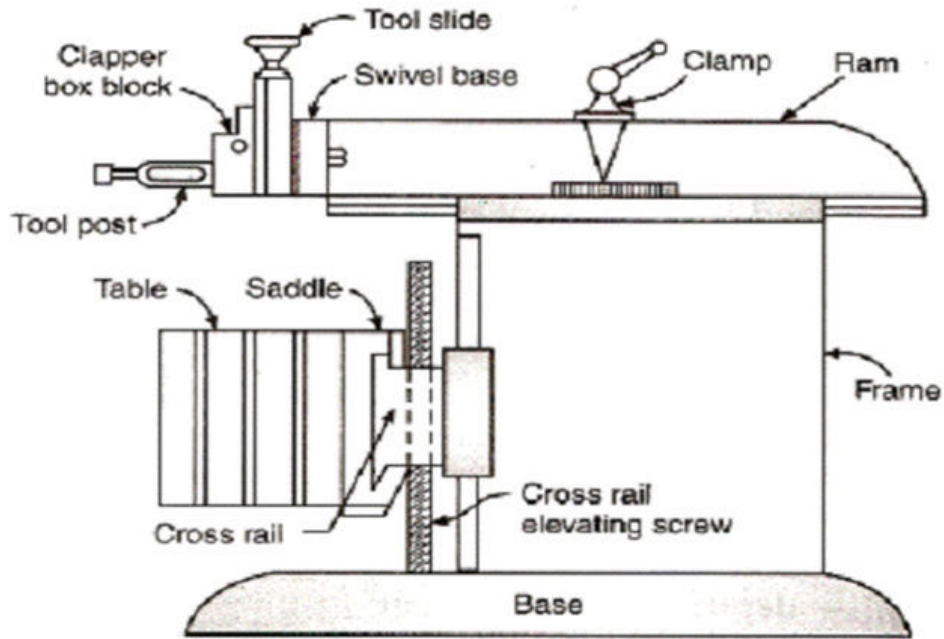

Fig. 13 The Shaper

**RESULT**

Thus the construction details and the working principle of the standard shaper are studied.

EX.NO:3

DATE :

**STUDY OF MILLING MACHINE**

**AIM**

To study the construction details and working principle of milling machine.

**CONSTRUCTION AND WORKING PRINCIPLE**

- A milling machine is a machine tool that removes metal from the work which is fed against a rotating multipoint cutter. The cutter rotates at a high speed and because of the multiple cutting edges it removes metal at a very fast rate.
- The base of the machine is grey iron casting, actually machined on its top and bottom surface. It carries the column at its one end. The column is the main support structure mounted vertically on the base. The column is box shaped, heavily ribbed inside and houses all the driving mechanism for the spindle and table feed. The front vertical face of column has details guide ways for supporting the knee. The top of the column is finished to hold on over arm that extends outward at front machine.

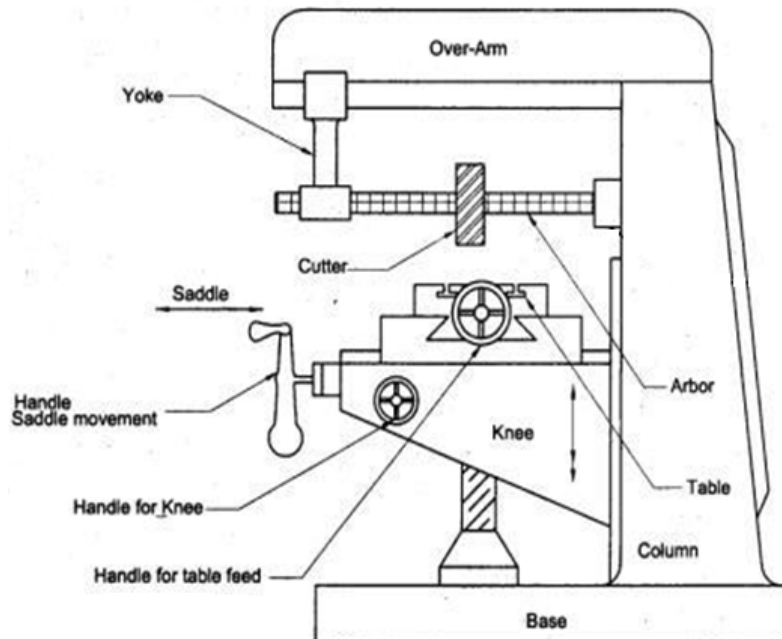

Fig. 14 The Milling Machine

## **ME 6311 - MANUFACTURING TECHNOLOGY LABORATORY-I**

---

- The knee is grid grey iron casting that slides up and down on the vertical away of column face. The knee gives the feed mechanism of table and different controls operate is saddle placed on top surfaces of knee which slides on guide ways perpendicular to column face. The feed movement of saddle is obtained by hand or by power.
- The overhanging arm is mounted on the top column the arm is adjusted so that bearing support may be provided of cutter. The spindle has the mouse taps at its front face in which various cutting tools may be inserted. The taper chance for proper alignment with the machine spindle handling taper holes at their none.

### **RESULT**

Thus the construction and working principle of milling machine is studied.

EX.NO:4

DATE :

**TAPER TURNING OPERATION BY USING A LATHE**

**AIM**

To machine a work piece by facing, plain turning and taper turning operation using a lathe.

**MATERIALS REQUIRED**

Mild steel polished round rod -  $\phi$  25 X 100 mm

**TOOLS REQUIRED**

- Lathe machine
- Steel Rule
- Cutting tool
- Vernier Caliper
- Outside Caliper
- Spanner

**FORMULA**

1) The taper angle is calculated using the following formula:

$$\text{Taper angle } (\infty) = \tan^{-1}\left(\frac{D-d}{2l}\right)$$

Where

D = large diameter of taper in mm

d = small diameter of taper in mm

l = length of tapered part in mm

$\infty$  = angle of taper

2) Time taken for taper turning :

$$T = \frac{\text{Length of the cut}}{[\text{Feed} \times \text{rpm}]} \times \text{Number of cuts}$$

Where,

Depth of the cut should not exceed 4mm

Cutting speed,  $S = 75 \text{ mm/rev}$

Maximum feed,  $f = 0.05 \text{ mm/rev}$

Rpm,  $N = [1000 \times S / \pi \times D]$

### **PROCEDURE**

1. The given work piece is held firmly in a lathe chuck.
2. The cutting tool is set in a tool post such that the point of the Cutting tool coincides with the lathe axis.
3. The machine is switched on to revolve the work piece at the selected speed.
4. By giving Cross feed and longitudinal feed to the cutting tool, the facing and turning operations are done respectively.
5. The compound rest is swiveled for the calculated taper angle.
6. By giving angular feed to the cutting tool through the compound slide the taper turning operation is done.
7. The machine is switched off.
8. The work piece is removed from the chuck and all the dimensions are measured and checked.

EX NO:4 TAPER TURNING

GIVEN JOB

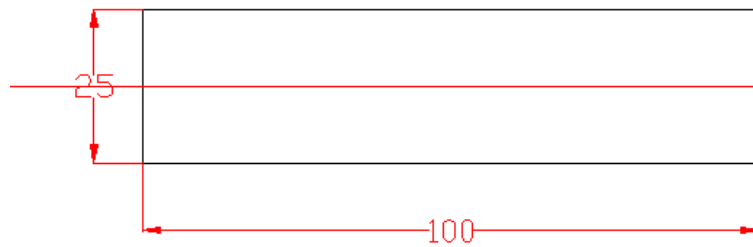

FINISHED JOB

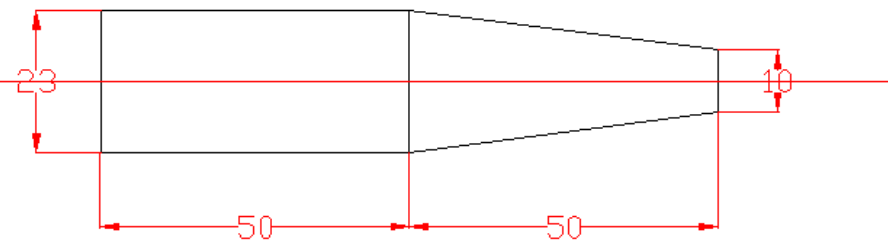

ALL THE DIMENSIONS ARE IN'mm'

**CALCULATION**

**1) Taper angle calculation:**

$$\begin{aligned} \text{Taper angle } (\alpha) &= \tan^{-1}\left(\frac{D-d}{2l}\right) \\ &= \tan^{-1}(23-10/2 \times 50) \end{aligned}$$

|                      |
|----------------------|
| $\alpha = 7.4^\circ$ |
|----------------------|

(2) →  $HG = HE \times \sin \theta$   
 $= 45 \times 0.14$

|                    |
|--------------------|
| <b>HG = 6.4 mm</b> |
|--------------------|

**Estimation of machining time:**

$$T = \frac{\text{Length of the cut}}{[\text{Feed} \times \text{rpm}]} \times \text{Number of cuts} \quad \text{----- (1)}$$

Let,

ED = Length of the cut required for taper turning

ED =  $\sqrt{DH^2 + HE^2}$

ED =  $\sqrt{6.5^2 + 45^2}$

ED =  $\sqrt{42.25 + 2025}$

|                      |
|----------------------|
| <b>ED = 45.46 mm</b> |
|----------------------|

Number of cut required:

$$= \frac{HG}{\text{Depth of cut}}$$

From  $\Delta GHE$ ,

$$\sin \theta = \frac{HG}{HE}$$

$$HG = HE \times \sin \theta \quad \text{----- (2)}$$

From  $\Delta DHE$ ,

$$\sin \theta = \frac{HG}{HE}$$

$$\sin \theta = \frac{6.5}{45.46}$$

$$= \mathbf{0.14}$$

No. of cuts = 6.4/4  
= 1.6

$$\approx \mathbf{2 \text{ cuts}}$$

Speed,  $N = (1000 \times S / \pi D)$   
 $= (1000 \times 75 / \pi \times 23)$

$$\mathbf{N = 1038.5 \text{ rpm}}$$

**ASSUME:**

- ✓ Depth cut should not exceed 1mm
- ✓ Cutting speed = 75 mm/min
- ✓ Max. feed = 0.05 mm/rev

(2)  $\rightarrow T = [(45.46 / 0.05 \times 1038.5) \times 2]$   
 $\mathbf{T=1.75 \text{ min.}}$

**RESULT**

The given work piece as shown in fig. is subjected to facing, plain turning and taper turning operation to become a finished work piece as shown in fig.

EX.NO:5

DATE :

**EXTERNAL THREAD CUTTING BY USING A LATHE**

**AIM**

To machine a work piece by facing, plain turning and external thread cutting operations using a lathe.

**MATERIALS REQUIRED**

- Mild steel polished round rod -  $\phi$  25 X 100 mm

**TOOLS REQUIRED**

- Outside Caliper
- Turning tool
- Vernier Caliper
- External V – thread cutting tool

**FORMULA**

***1) Time taken for external threads:***

$$T = \frac{\text{Length of the cut}}{[\text{pitch} \times \text{rpm}]} \times \text{Number of cuts}$$

***2) Number of cuts***

$$T = \frac{25}{\text{Threads per 'cm'}} \text{ for external threads}$$

**PROCEDURE**

1. The given work piece is held firmly in a lathe chuck.
2. The cutting tool is set in a tool post such that the point of the Cutting tool coincides with the lathe axis.
3. The machine is switched on to revolve the work piece at the selected speed.
4. By giving Cross feed and longitudinal feed to the cutting tool, the facing and turning operations are done respectively.
5. The speed of the work piece is reduced.
6. The machine is switched off and the change gears of calculated teeth (as per calculation) are connected.
7. Again the machine is switched on.
8. The external thread cutting operation is done using external thread cutting tool by engaging thread cutting mechanism.
9. The machine is switched off.
10. The work piece is removed from the chuck and all the dimensions are measured and checked.

EX NO: 5 EXTERNAL THREAD CUTTING

GIVEN JOB

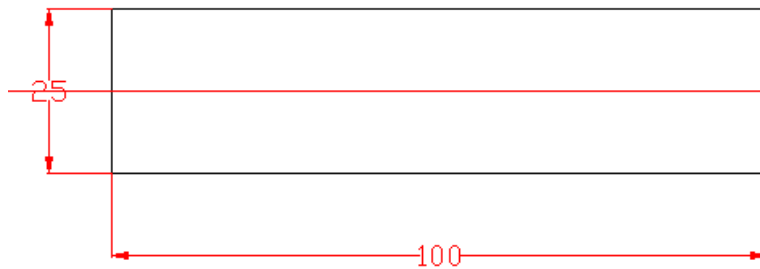

FINISHED JOB

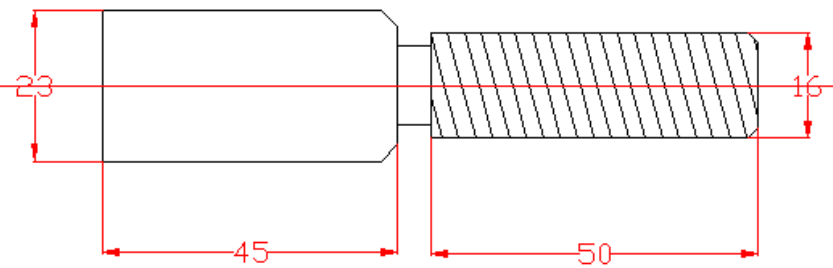

ALL DIMENSIONS ARE IN mm

**CALCULATION**

The number of teeth on change gears is calculated using the following formula:

$$\text{Driver teeth/ Driven teeth} = \text{Pitch of the work} / \text{pitch of the lead screw}$$

**RESULT**

The given work piece as shown in fig. is subjected to facing, plain turning, knurling and external thread cutting operations to become a finished work piece as shown in fig.

**EX.NO:6**

**DATE :**

**KNURLING OPERATION BY USING A LATHE**

**AIM**

To machine a work piece by facing, plain turning, knurling operations using a lathe.

**MATERIALS REQUIRED**

- Mild steel polished round rod -  $\phi$  25 X 100 mm

**TOOLS REQUIRED**

- Lathe machine
- Turning tool
- Knurling tool
- Outside Caliper
- Steel Rule
- Vernier Caliper

**FORMULA**

Time taken for knurling:

$$T = \frac{\text{Length of the cut}}{\text{[Feed x rpm]}}$$

## EX NO: 6 KNURLING

GIVEN JOB

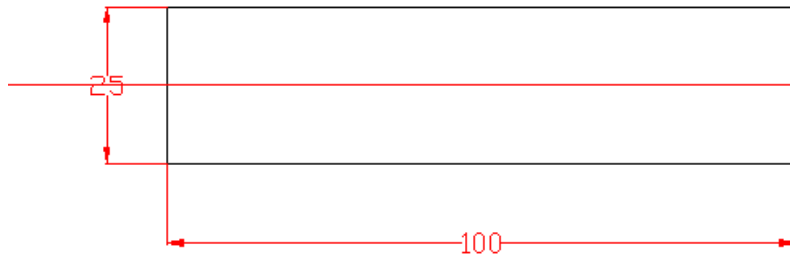

FINISHED JOB

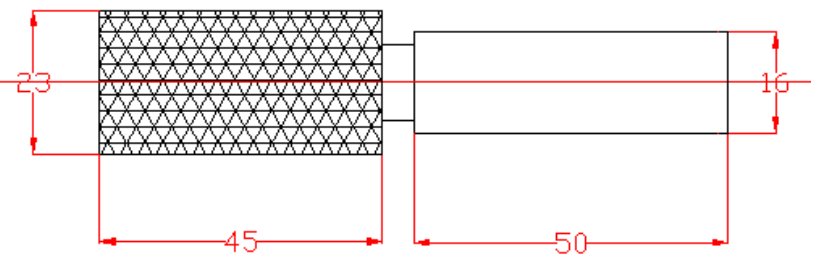

ALL DIMENSIONS ARE IN mm

**PROCEDURE**

1. The given work piece is held firmly in a lathe chuck.
2. The cutting tool is set in a tool post such that the point of the Cutting tool coincides with the lathe axis.
3. The machine is switched on to revolve the work piece at the selected speed.
4. By giving Cross feed and longitudinal feed to the cutting tool, the facing and turning operations are done respectively.
5. The speed of the work piece is reduced.
6. The knurling operation is done using knurling tool.
7. Again the machine is switched on.
8. The machine is switched off.
9. The work piece is removed from the chuck and all the dimensions are measured and checked.

**RESULT**

The given work piece as shown in fig. is subjected to facing, plain turning, knurling operations to become a finished work piece as shown in fig.

EX.NO:7

DATE :

**INTERNAL THREAD CUTTING BY USING A LATHE**

**AIM**

To machine a work piece by facing, plain turning and internal thread cutting operations using a lathe.

**MATERIALS REQUIRED**

- Mild steel polished round rod -  $\phi$  25 X 100 mm

**TOOLS REQUIRED**

- Lathe machine
- Outside Caliper
- Turning tool
- Steel Rule
- Vernier Caliper
- Internal V – thread cutting tool

**FORMULA**

1) *Time taken for internal threads:*

$$T = \frac{\text{Length of the cut}}{[\text{Pitch} \times \text{rpm}]} \times \text{Number of cuts}$$

2) *Number of cuts:*

$$T = \frac{32}{\text{Threads per 'cm'}} \text{ for external threads}$$

**PROCEDURE**

1. The given work piece is held firmly in a lathe chuck.
2. The cutting tool is set in a tool post such that the point of the Cutting tool coincides with the lathe axis.
3. The machine is switched on to revolve the work piece at the selected speed.
4. By giving Cross feed and longitudinal feed to the cutting tool, the facing and turning operations are done respectively.
5. The speed of the work piece is reduced.
6. The machine is switched off and the change gears of calculated teeth(as per calculation) are connected.
7. Again the machine is switched on.
8. The internal thread cutting operation is done using internal thread cutting tool by engaging thread cutting mechanism.
9. The machine is switched off.
10. The work piece is removed from the chuck and all the dimensions are measured and checked.

EX NO: 7 INTERNAL THREAD CUTTING

GIVEN JOB

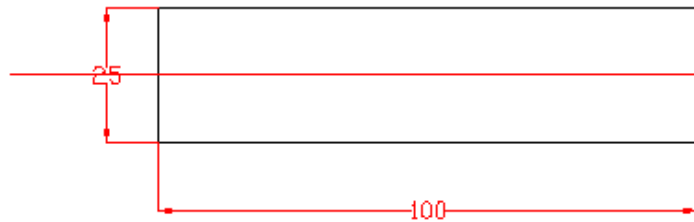

FINISHED JOB

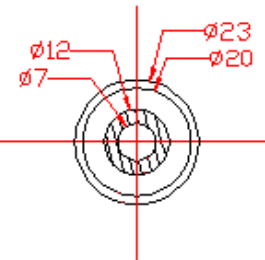
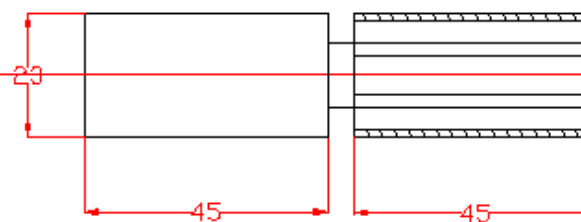

ALL DIMENSIONS ARE IN mm

**CALCULATION**

The number of teeth on change gears is calculated using the following formula:

$$\text{Driver teeth/ Driven teeth} = \text{Pitch of the work} / \text{pitch of the lead screw}$$

**RESULT**

The given work piece as shown in fig. is subjected to facing, plain turning, and internal thread cutting operations to become a finished work piece as shown in fig.

**EX.NO :8**

**DATE :**

**ECCENTRIC TURNING OPERATION BY USING A LATHE**

**AIM**

To machine a work piece by facing, plain turning, eccentric operations by use a four jaw chuck lathe.

**MATERIALS REQUIRED**

- Mild steel polished round rod -  $\phi$  25 X 100 mm

**TOOLS REQUIRED**

- Four jaw chuck lathe
- Outside Caliper
- Turning tool
- Vernier caliper
- Steel Rule

**FORMULA**

- |                               |   |                                      |
|-------------------------------|---|--------------------------------------|
| 1) Speed , N                  | = | $1000 \times s / \pi \times D$       |
| 2) No. of passes              | = | $D-d / 2 \times \text{depth of cut}$ |
| 3) Time for eccentric turning | = | $L / F \times N$                     |

**EX NO: 8 ECCENTRIC TURNING**

GIVEN JOB

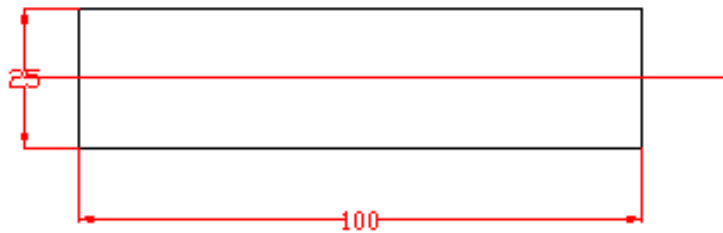

FINISHED JOB

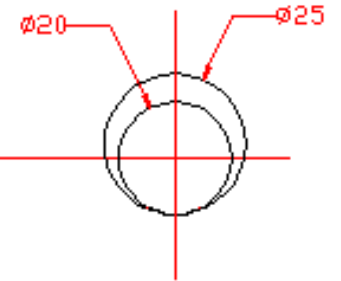
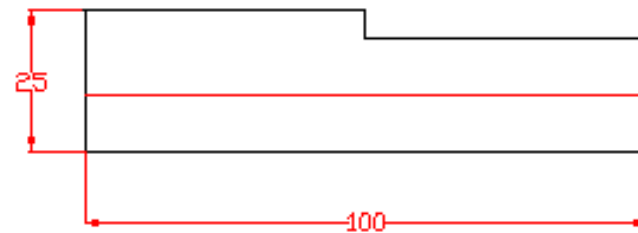

ALL DIMENSIONS ARE IN mm

**PROCEDURE**

1. The given work piece is held firmly in a lathe chuck.
2. The cutting tool is set in a tool post such that the point of the Cutting tool coincides with the lathe axis.
3. The machine is switched on to revolve the work piece at the selected speed.
4. By giving Cross feed and longitudinal feed to the cutting tool, the facing and turning operations are done respectively.
5. The speed of the work piece is reduced.
6. The four jaw chuck is manually adjusted for the offset purpose to make the eccentricity.
7. Again the machine is switched on.
8. The machine is switched off.
9. The work piece is removed from the chuck and all the dimensions are measured and checked.

**RESULT**

The given work piece as shown in fig. is subjected to facing, plain turning, knurling operations to become a finished work piece as shown in fig.

EX.NO:9

DATE :

**MACHINING HEXAGON FROM ROUND ROD BY USING A MILLING  
MACHINE**

**AIM**

To machine a hexagon in the given work piece to the dimensions as shown in the figure using Shaping Machine.

**TOOLS REQUIRED**

- Milling Machine,
- Scriber, Divider,
- Steel Rule,
- Chalk piece,
- Bevel Protractor.

**FORMULA**

1) *Time taken for milling:*

$$T = \frac{\text{Length of the job + added table travel}}{(\text{feed / rev}) \times (\text{r.p.m})}$$

2) *Feed / rev :*

$$\text{Feed / rev} = \{\text{feed per teeth}\} \times \{\text{no. of cutter teeth}\}$$

EX NO:9 ROUND TO HEXAGON IN MILLING MACHINE

GIVEN JOB

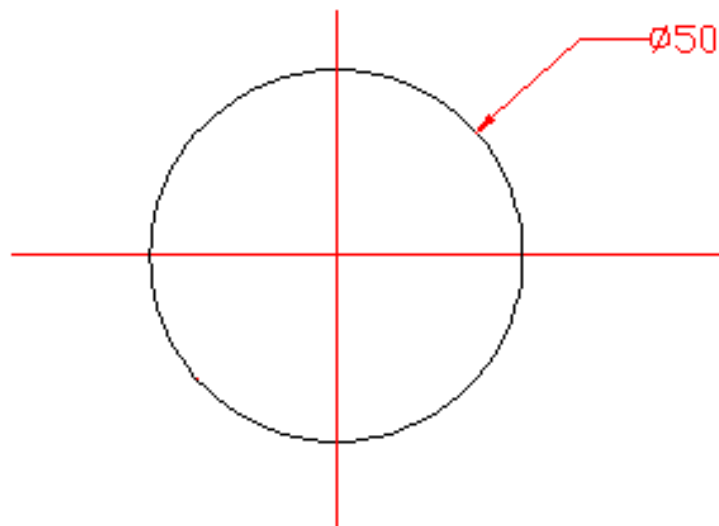

FINISHED JOB

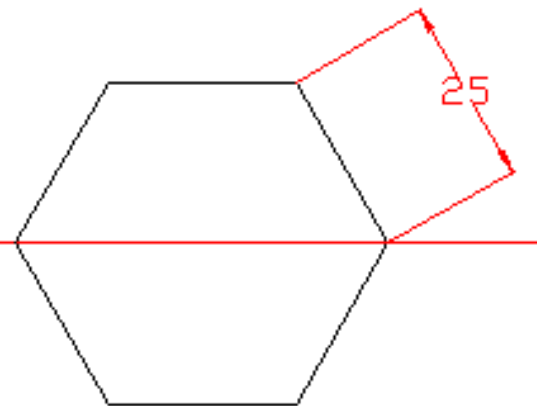

ALL THE DIMENSIONS ARE IN 'mm'

**PROCEDURE**

1. The given work piece is measured for its initial dimensions.
2. With the help of scribe, mark the hexagon dimensions in the work piece.
3. Fix the work piece in the vice of the shaping machine.
4. After fixing the work piece and the shaping tool, allow the ram to reciprocate.
5. Start the shaping process by giving the required depth by lowering the tool.
6. Slowly increase the depth of cut and repeat the procedure to make the hexagon shape.
7. The work piece is now checked for final dimensions.

**RESULT**

Thus, a hexagon is machined in the given workpiece to the dimensions as shown in the figure using Shaping Machine.

EX.NO:10

DATE :

**MACHINING SQUARE FROM ROUND ROD BY USING A SHAPER**

**AIM**

To generate a square from rounded on the given work piece in a shaper machine.

**TOOLS REQUIRED**

- Shaping machine
- Steel rule
- Hammer
- Shaper tool
- Try Square

**FORMULA**

**1) Time taken for shaping:**

$$T = \frac{L(1+K)}{S \times 1000} \times \frac{W}{f} \times P$$

Where,

- L = Length of forward stroke in 'mm'
- K = (time for return stroke / time for forward stroke)
- w = width of the job in mm
- S = Cutting speed in mm
- F = feed per stroke
- p = number of cuts( or) passes required

**2) No. of cuts P:**

$$P = \frac{\text{Depth of metal removed}}{\text{Feed per stroke}}$$

## EX NO:10 ROUND TO SQUARE IN SHAPER MACHINE

GIVEN JOB

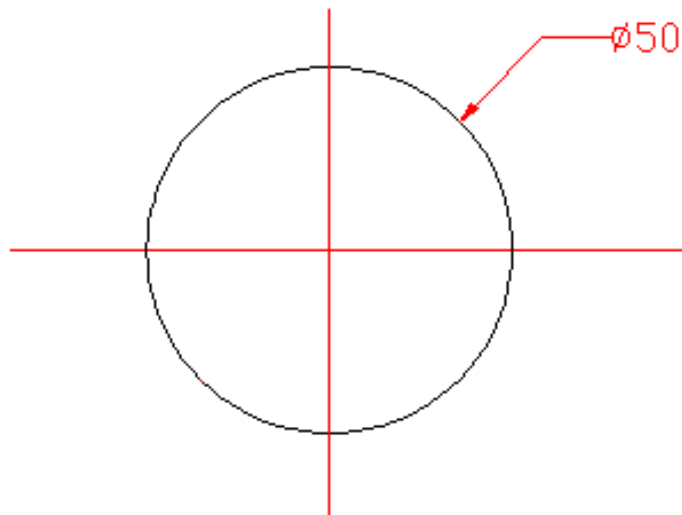

FINISHED JOB

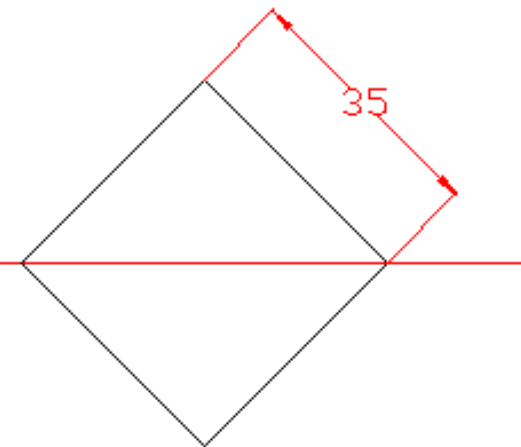

ALL THE DIMENSIONS ARE IN 'mm'

**PROCEDURE**

1. The job was checked to the given dimensions.
2. The square was scribed in the outer circle of diameter exactly and punching was done.
3. The job was attached in the vice of a shaper.
4. The job was checked for perpendicular dimension.
5. Then the square from round was obtained in the shaper.
6. The work piece was removed and burrs are removed with accuracy was checked.

**RESULT**

Thus the square from round was performed on the given dimension in a shaper machine with the required dimensions.